

**CATALOG
2023**

MTM

HYDRO

**CAR WASH
EQUIPMENT**
100% MADE IN ITALY



MTM
HYDRO

MTM
HYDRO

Con oltre 30 anni di esperienza MTM Hydro si pone sul mercato quale azienda leader nella progettazione e produzione di Componenti e Accessori per Idropultrici e Autolavaggi e, più recentemente, nella ideazione e realizzazione di macchine Self Service di complemento per l'autolavaggio, con la vasta gamma Car Wash Equipment. MTM Hydro si pone nei confronti della clientela non come un semplice fornitore ma come il partner ideale, attento e pronto a rispondere a tutte le esigenze.

With over 30 years of experience, MTM Hydro is the market leader in the design and manufacturing of components and accessories for high pressure cleaners and car wash centers, and more recently in the design and construction of Self-Service Car Wash machines with its Car Wash Equipment range. MTM Hydro relates to its clientele not simply as a supplier, but rather as an ideal partner ready to respond and meet the individual needs of your company.



La MTM Hydro Srl si riserva tutti i diritti per la totalità dei contenuti (testi, immagini, etc.) che appaiono sul presente catalogo. Tali contenuti possono essere utilizzati da terzi soltanto previo consenso scritto. Le informazioni contenute, quali caratteristiche tecniche dei prodotti, dimensioni, schemi di montaggio, colori etc. hanno valore meramente indicativo, in ragione delle specifiche tecniche e della evoluzione tecnologica dei prodotti aziendali. Al fine di migliorare la qualità del prodotto, la MTM Hydro Srl si riserva il diritto di modificare lo stesso senza alcun preavviso declinando ogni responsabilità su eventuali dati inesatti.

M.T.M. Hydro S.r.l. reserves all the content rights (texts and images, etc.) showed on our brochures. Those contents can be used from others just after the approval from our company. The information available on the brochures, as technical features of our products, sizes and the instructions manuals, colours, etc. are indicative information based on the technical specifications and the technologic evolution of the products. M.T.M. Hydro reserves the right to edit those information with the purpose of improving the quality of the products without having to inform about the changes and disclaiming any responsibility.

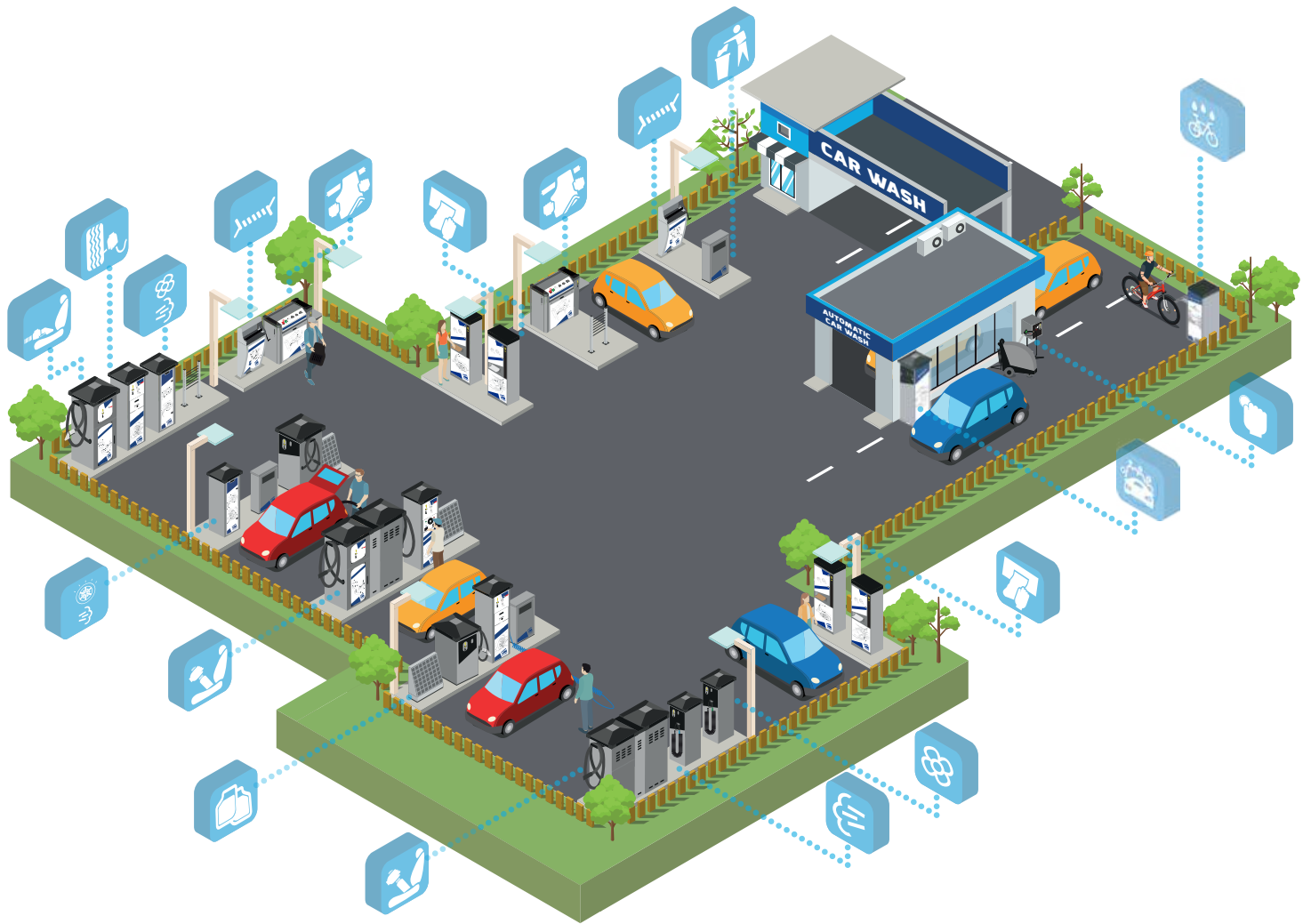

 **ASPIRATORI SELF**
SELF VACUUMS

 **LAVATAPPETI**
MAT CLEANERS

 **LAVAINTERNI**
CAR SEAT WASH

 **DISTRIBUTORI PRODOTTI IN ROTOLO**
ROLL PRODUCT DISTRIBUTORS

 **GONFIAGOMME**
TIRE INFLATORS

 **STRIZZAPELLE**
WRINGING MACHINES

 **BATTITAPPETO**
MAT BEATERS













 **PORTARIFIUTI**
WASTE BINS

 **MODULI STARTER**
STERTER MODULES

 **MODULI MULTIFUNZIONE PER LAVAGGIO**
MULTIFUNCTION WASH MODULE

 **COLONNINE EROGATRICI**
DISPENSING COLUMNS

INDICE · INDEX

01. ASPIRATORI SELF · SELF VACUUM CLEANERS	009	
02. LAVATAPPETI · MAT CLEANERS	057	
03. LAVAINTERNI · CAR SEAT WASH	063	
04. DISTRIBUTORI PRODOTTO IN ROTOLO · ROLL PRODUCT DISTRIBUTORS	079	
05. GONFIAGOMME · TIRE INFLATORS	091	
06. COLONNINE EROGATRICI · DISPENSING COLUMNS	107	
07. MODULI MULTIFUNZIONE PER LAVAGGIO · MULTIFUNCTIONAL WASH MODULES	133	
08. STRIZZAPELLE · WRINGING MACHINES	165	
09. BATTITAPPETO · MAT BEATERS	169	
10. PORTARIFIUTI A PEDALE · PEDAL WASTE BINS	173	
11. MODULI STARTER · STARTER MODULES	175	
12. GENERATORE ELETTRICO DI ARIA CALDA · ELECTRICAL SPACE HEATER	177	
13. GRAFICHE DISPONIBILI · AVAILABLE GRAPHICS	179	

NUOVI PRODOTTI
NEW PRODUCTS

CWE CONNECT

CONTROLLO REMOTO MACCHINE CAR WASH / CAR WASH MACHINES REMOTE CONTROLLER SYSTEM



CARATTERISTICHE / FEATURES

■ CONTROLLO MACCHINE PRESENTI NELL'IMPIANTO TRAMITE UNICO MONITOR CON POSSIBILITÀ DI VISUALIZZARE:

- CICLI TOTALI IMPIANTO
- CICLI TOTALI SINGOLA MACCHINA
- INCASSO TOTALE IMPIANTO
- INCASSO TOTALE SINGOLA MACCHINA (per ogni macchina si potrà poi ancora scindere se il pagamento è stato fatto tramite gettone - moneta - chiavi - tessere - etc.)
- ALLARMI SINGOLA MACCHINA(bidone aspiratore pieno, liquidi in esaurimento, mancanza carta/panno etc.)

■ CONTROL OF THE MACHINES PRESENT IN THE SYSTEM VIA A SINGLE MONITOR WITH THE POSSIBILITY OF VIEWING:

- TOTAL SYSTEM CYCLES
- SINGLE MACHINE TOTAL CYCLES
- TOTAL SYSTEM RECEIPT
- TOTAL SINGLE MACHINE COLLECTION (for each machine it can still be separated if the payment was made by token - coin - keys - cards - etc.)
- SINGLE MACHINE ALARMS (full vacuum bin, low liquids, no paper / skin etc.)

■ ALIMENTAZIONE 230V-50 HZ

■ POWER SUPPLY 230 V

■ COLLEGAMENTO MACCHINE A DISPOSITIVO TRAMITE RETE "CAN BUS"

■ CONNECTION OF MACHINES TO DEVICE VIA "CAN BUS" NETWORK

■ POSSIBILITÀ CONNESSIONE PER VISUALIZZAZIONE DATI TRAMITE PC, SMARTPHONE ETC.

■ CONNECTION FOR DATA DISPLAY VIA PC, SMARTPHONE ETC.

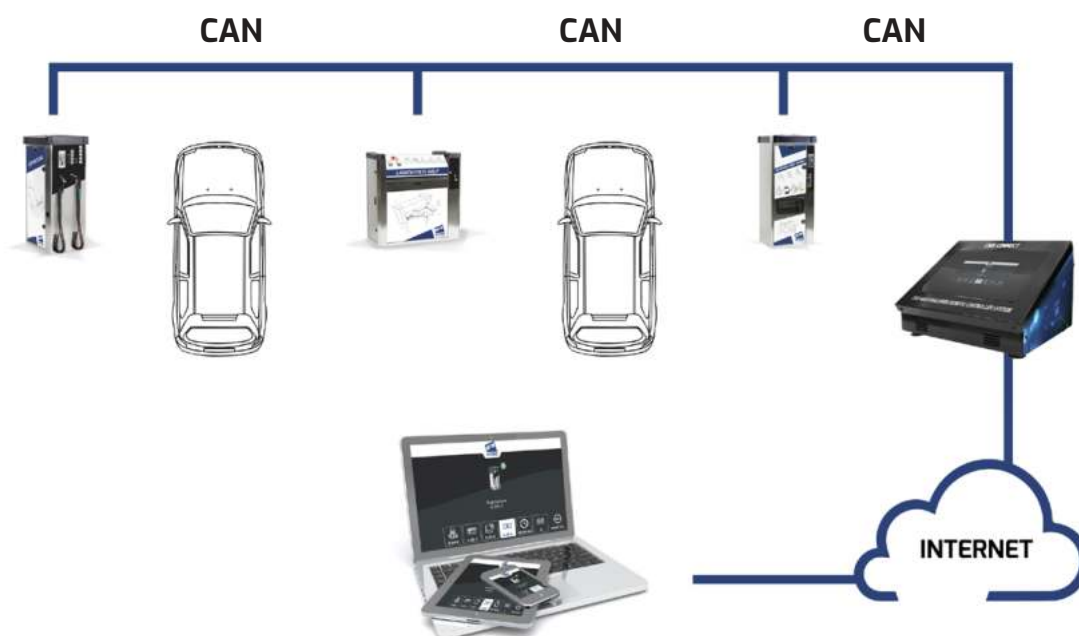

CARATTERISTICHE TECNICHE / TECHNICAL FEATURES

Codice Part No.	Descrizione Description				Peso Weight	
3160110001	CWE CONNECT				6 kg	
DIMENSIONI DIMENSIONS			IMBALLO (SCATOLA CARTONE) PACKAGING (CARTON BOX)			
A (mm)	B (mm)	C (mm)	X (mm)	Y (mm)	Z (mm)	
327	250	219	400	300	230	

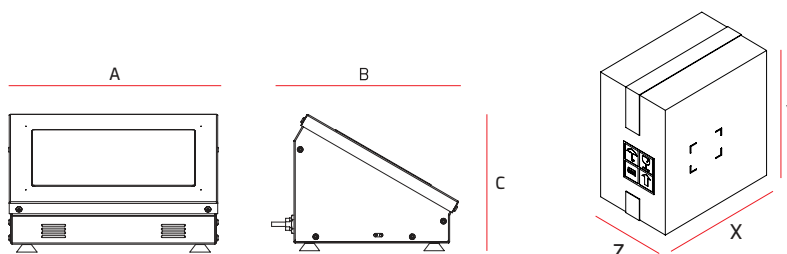

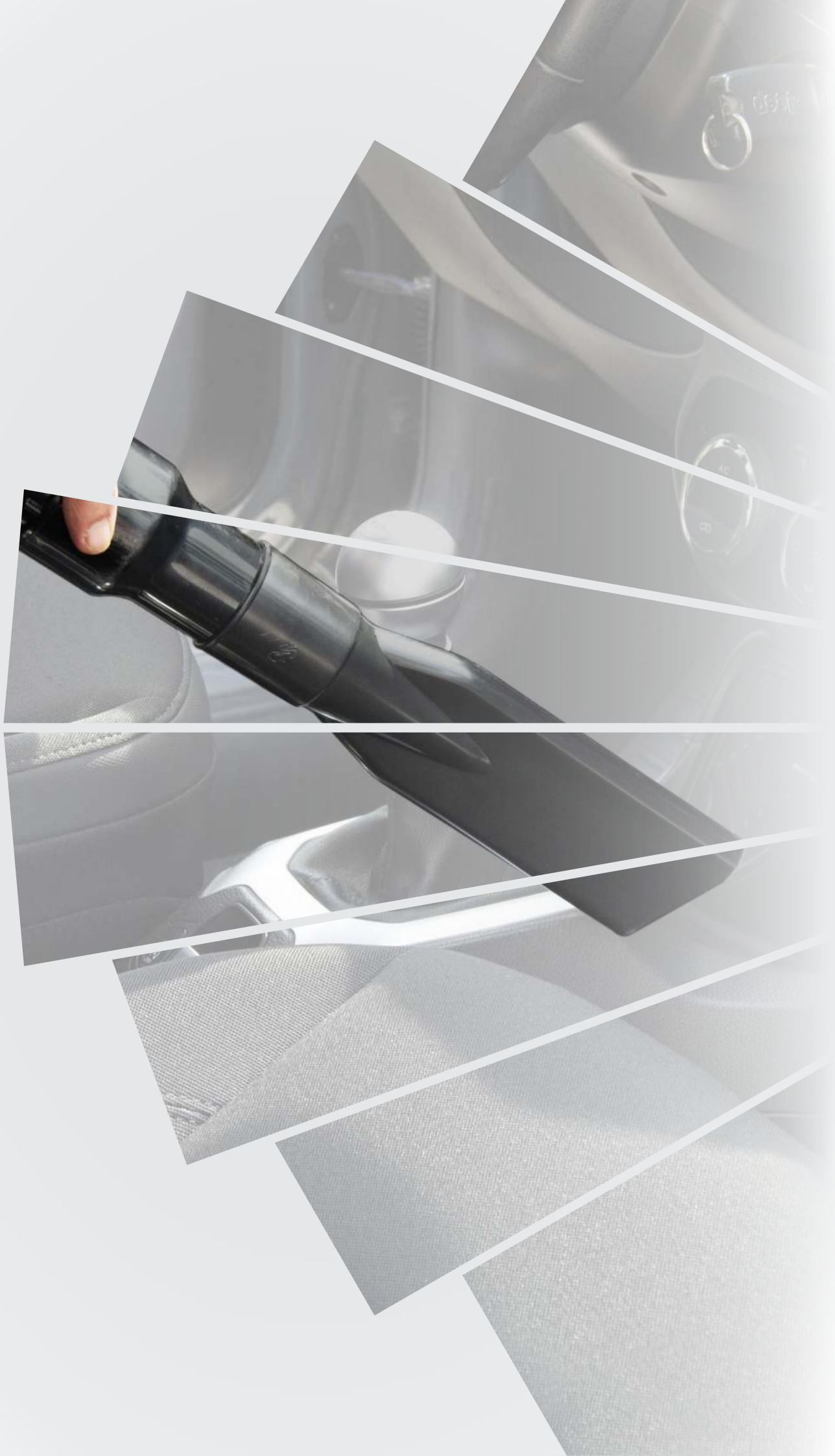

01 ASPIRATORI SELF VACUUM CLEANERS

01	AS1 ASPIRATORE SELF SINGOLO · SINGLE SELF VACUUM CLEANER	011
02	AS1-E ASPIRATORE SELF CON RICARICA AUTO ELETTRICA INTEGRATA SELF VACUUM CLEANER WITH INTEGRATED ELECTRIC CAR CHARGER	015
03	AS2 ASPIRATORE SELF DOPPIO · DOUBLE SELF VACUUM CLEANER	019
04	AF1 - AF1 AIR - AF1 AIR PLUS ASPIRATORE SELF SINGOLO · SINGLE SELF VACUUM CLEANER	023
05	AF2 - AF2 AIR - AF2 AIR PLUS ASPIRATORE SELF DOPPIO · DOUBLE SELF VACUUM CLEANER	029
06	AC1 - AC1 AIR - AC1 AIR PLUS ASPIRATORE SELF SINGOLO · SINGLE SELF VACUUM CLEANER	035
07	AC2 - AC2 AIR - AC2 AIR PLUS ASPIRATORE SELF DOPPIO · DOUBLE SELF VACUUM CLEANER	041
08	AL1 ASPIRATORE SELF SINGOLO · SINGLE SELF VACUUM CLEANER	047
09	AL2 ASPIRATORE SELF DOPPIO · DOUBLE SELF VACUUM CLEANER	051



L'**ACCIAIO INOX** che utilizziamo per le nostre macchine è del tipo AISI 304 quindi a basso contenuto di carbonio.

I principali vantaggi di questo materiale per le nostre applicazioni sono:

- Elevata resistenza alle intemperie e corrosione
- Facilità di ripulitura e ottimo coefficiente igienico

*The **STAINLESS STEEL** used in the construction of our machines is of the type AISI 304 with low carbon content.*

The main advantages of this material for our applications are:

- High level of resistance to extreme weather and corrosion
- Ease of cleaning and maintenance and excellent hygiene properties



La **TURBINA** garantisce una elevata affidabilità e durata nel tempo oltreché elevata silenziosità di funzionamento, assenza di vibrazioni e non ultimo assenza di manutenzione.

*The **TURBINE** guarantees a high level of reliability and durability over time as well as low-noise functioning, lack of vibrations and last but not least is completely maintenance-free.*



IL **MOTORE BISTADIO con RAFFREDDAMENTO BYPASS** aspira ed espelle l'aria in due tempi creando un "maggiore vuoto" e quindi un'aspirazione più potente.

*The **TWO STAGES MOTOR with BYPASS COOLING** sucks and expels the air in two times creating a "greater vacuum" and therefore a more powerful suction.*

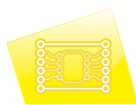

SCHEMA ELETTRONICA, dotata di temporizzatore elettronico, svolge una o più azioni a intervalli di tempo prefissati, facilmente regolabile secondo le esigenze del cliente.

*The **ELECTRONIC CIRCUIT BOARD**, supplied with an electronic timer, manages one or more functions at prefixed intervals, and is easily adjustable according to the client's needs.*



La **GETTONIERA ELETTRONICA**, offerta di serie, combina una straordinaria selettività ad un'estrema versatilità di programmazione.

*The **ELECTRONIC TOKEN AND COIN-OP** mechanism, supplied as standard equipment, combines extraordinary versatility with extreme programming flexibility.*



Nelle nostre macchine utilizziamo esclusivamente **TUBI, BOCCHETTE E RACCORDI IN PLASTICA** di tipo universale quindi di facile reperibilità nel mercato del ricambio.

*In the construction of our machines, we use universal plastic **TUBES, NOZZLES AND JOINTS**, easily available in the spare parts supply market.*



Il nostro sistema elettromeccanico di **PULIZIA AUTOMATICA DEL FILTRO** dopo ogni ciclo di aspirazione, facilita l'eliminazione della micro-polvere dal filtro a cartuccia, mantenendo quindi una migliore efficienza di aspirazione nel tempo nonché ridotta manutenzione.

*Our electromechanical **AUTOMATIC FILTER CLEANING** mechanism, cleans the filter after every vacuum cycle thereby facilitating the elimination of fine dust from the cartridge filter, and maintaining a high vacuum efficiency and reducing maintenance at the same time.*



IL **MODULO DI RICARICA** eroga corrente alternata mediante presa standard tipo 2.

*The **RECHARGE MODULE** supplies AC through a standard type 2 socket.*

	A51	A51-E	A52	ACT	ACT AIR	ACT AIR PLUS	AC2	AC2 AIR	AC2 AIR PLUS	AF2	AF2 AIR	AF2 AIR PLUS	AL1	AL2
L'ACCIAIO INOX che utilizziamo per le nostre macchine è del tipo AISI 304 quindi a basso contenuto di carbonio. I principali vantaggi di questo materiale per le nostre applicazioni sono: Elevata resistenza alle intemperie e corrosione Facilità di ripulitura e ottimo coefficiente igienico	✓	✓	✓	✓	✓	✓	✓	✓	✓	✓	✓	✓	✓	✓
La TURBINA garantisce una elevata affidabilità e durata nel tempo oltreché elevata silenziosità di funzionamento, assenza di vibrazioni e non ultimo assenza di manutenzione.	✓	✓	✓	✓	✓	✓	✓	✓	✓	✓	✓	✓		
IL MOTORE BISTADIO con RAFFREDDAMENTO BYPASS aspira ed espelle l'aria in due tempi creando un "maggiore vuoto" e quindi un'aspirazione più potente.													✓	✓
SCHEMA ELETTRONICA, dotata di temporizzatore elettronico, svolge una o più azioni a intervalli di tempo prefissati, facilmente regolabile secondo le esigenze del cliente.	✓	✓	✓	✓	✓	✓	✓	✓	✓	✓	✓	✓	✓	✓
La GETTONIERA ELETTRONICA, offerta di serie, combina una straordinaria selettività ad un'estrema versatilità di programmazione.	✓	✓	✓	✓	✓	✓	✓	✓	✓	✓	✓	✓	✓	✓
Nelle nostre macchine utilizziamo esclusivamente TUBI, BOCCHETTE E RACCORDI IN PLASTICA di tipo universale quindi di facile reperibilità nel mercato del ricambio.	✓	✓	✓	✓	✓	✓	✓	✓	✓	✓	✓	✓	✓	✓
Il nostro sistema elettromeccanico di PULIZIA AUTOMATICA DEL FILTRO dopo ogni ciclo di aspirazione, facilita l'eliminazione della micro-polvere dal filtro a cartuccia, mantenendo quindi una migliore efficienza di aspirazione nel tempo nonché ridotta manutenzione.	✓	✓	✓	✓	✓	✓	✓	✓	✓	✓	✓	✓		
IL MODULO DI RICARICA eroga corrente alternata mediante presa standard tipo 2.		✓												



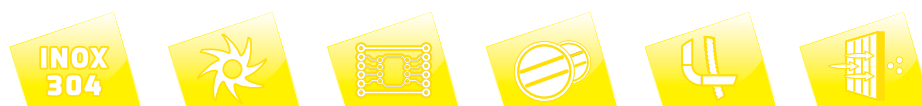

AS1

ASPIRATORE SELF SINGOLO / SINGLE SELF VACUUM CLEANER

CARATTERISTICHE / FEATURES

- CHIUSURA A DUE PUNTI ANTIVANDALO
 - ACCESSO SEPARATO AL BIDONE PER LA MANUTENZIONE ORDINARIA
 - CONTENITORE GETTONI LUCCHETTABILE
 - TEMPO CICLO PROGRAMMABILE
 - AVVIAMENTO MANUALE A RICHIESTA
 - CALOTTA IN ABS RESISTENTE AI RAGGI UV
 - INNOVATIVO SISTEMA DI RAFFREDDAMENTO DELLA TURBINA
 - QUADRO ELETTRICO E GETTONIERA ELETTRONICA INTEGRATI E DI FACILE ACCESSO

 - VANDAL-PROOF DOORS AND LOCKS
 - SEPARATE ACCESS TO CONTAINER FOR ORDINARY MAINTENANCE
 - LOCKABLE TOKEN/COIN COMPARTMENT
 - PROGRAMMABLE CYCLE TIME
 - MANUAL START ON DEMAND
 - ABS COVER, RESISTANT TO UV RAYS
 - REVOLUTIONARY INTERNAL COOLING SYSTEM
 - EASY ACCESS INTEGRATED ELECTRONIC CONTROL BOARD



ACCESSORI IN DOTAZIONE / SUPPLIED ACCESSORIES

TUBO FLESSIBILE Ø 40 mm LUNGHEZZA 5 m
FLEXIBLE HOSE Ø 40 mm LENGHT 5 m

KIT ACCESSORI PER TUBO FLESSIBILE
FLEXIBLE HOSE ACCESSORIES KIT

COPERTURA GETTONIERA
COIN ACCEPTOR PROTECTION

BIDONE E FILTRO
A SCELTA TRA
CHOOSE THE BIN
AND THE FILTER AMONG

KIT BIDONE ASPIRATORE
70 L FILTRO POLIESTERE
VACUUM BIN 70 L
POLYESTER FILTER

FILTRO POLIESTERE COMPLETO
COMPLETE POLYESTER FILTER

KIT BIDONE ASPIRATORE
70 L FILTRO A PERDERE
VACUUM BIN 70 L
DISPOSABLE FILTER BAG

SACCO FILTRO A PERDERE 60 L
DISPOSABLE FILTER BAG 60 L

KIT BIDONE ASPIRATORE 70 L
CON PULIZIA AUTOMATICA
VACUUM BIN 70 L WITH
AUTOMATIC CLEANING

FILTRO CARTUCCIA
CARTRIDGE FILTER

QR CODE

ACCESSORI A RICHIESTA / ACCESSORIES ON DEMAND

BRACCIO A MOLLA VERTICALE INOX
S STEEL VERTICAL BOOM

KIT EUROKEY NEXT
EUROKEY NEXT KIT

DISPLAY

KIT ARIA COMPRESA
COMPRESSED AIR KIT

KIT ILLUMINAZIONE LED
LED LIGHT KIT

KIT ISOLAMENTO ACUSTICO
SOUNDPROOFING KIT

KIT SOFFIAGGIO ARIA
BLOWING AIR KIT

KIT NEBULIZZATORE
SPRAY KIT

KIT NEROGOMME
TIRE BLACKENING KIT

ETICHETTA (vedere pag. 167)
LABEL (see on pg. 167)

CARATTERISTICHE TECNICHE / TECHNICAL FEATURES

Codice Part No.	Potenza Power	Tensione Voltage	Portata d'Aria Air flow	Alimentazione Power Supply	Peso Totale Total Weight	Filtro Filter
3010110005	2,2 kW	230 V - 50 Hz	320 m ³ /h	230 V- 50 Hz	130 kg	a perdere / disposable
3010110006	2,2 kW	230 V - 50 Hz	320 m ³ /h	230 V- 50 Hz	130 kg	poliestere / polyester
3010210003	2,2 kW	230 V - 50 Hz	320 m ³ /h	230 V - 50 Hz	130 kg	automatico / automatic
3010120005	2,2 kW	400 V - 50 Hz	320 m ³ /h	400 V - 50 Hz 5 POLI R-S-T+N	130 kg	a perdere / disposable
3010120006	2,2 kW	400 V - 50 Hz	320 m ³ /h	400 V - 50 Hz 5 POLI R-S-T+N	130 kg	poliestere / polyester
3010220003	2,2 kW	400 V - 50 Hz	320 m ³ /h	400 V - 50 Hz 5 POLI R-S-T+N	130 kg	automatico / automatic
3010140005	3 kW	400 V - 50 Hz	370 m ³ /h	400 V - 50 Hz 5 POLI R-S-T+N	140 kg	a perdere / disposable
3010140006	3 kW	400 V - 50 Hz	370 m ³ /h	400 V - 50 Hz 5 POLI R-S-T+N	140 kg	poliestere / polyester
3010240003	3 kW	400 V - 50 Hz	370 m ³ /h	400 V - 50 Hz 5 POLI R-S-T+N	140 kg	automatico / automatic

ACCESSORI IN DOTAZIONE / SUPPLIED ACCESSORIES

ACCESSORI A RICHIESTA / ACCESSORIES ON DEMAND

Codice Part No.	Descrizione Description	Codice Part No.	Descrizione Description
0964550011	TUBO FLESSIBILE Ø 40 mm LUNGHEZZA 5 m FLEXIBLE HOSE Ø 40 mm LENGHT 5 m	0445611009	KIT NEBULIZZATORE SPRAY KIT
0090611001	KIT ACCESSORI PER TUBO FLESSIBILE FLEXIBLE HOSE ACCESSORIES KIT	0445611010**	KIT ARIA COMPRESSA COMPRESSED AIR KIT
0075611017*	KIT BIDONE ASPIRATORE 70 l FILTRO POLIESTERE VACUUM BIN 70 l POLYESTER FILTER	0445611008	KIT NEROGOMME TIRE BLACKENING KIT
0330211002*	FILTRO POLIESTERE COMPLETO COMPLETE POLYESTER FILTER	0445611024	KIT SOFFIAGGIO ARIA AIR BLOWING KIT
0075611016*	KIT BIDONE ASPIRATORE 70 l FILTRO A PERDERE VACUUM BIN 70 l DISPOSABLE FILTER BAG	0495022001	KIT EUROKEY NEXT EUROKEY NEXT KIT
0800020001*	SACCO FILTRO A PERDERE 60 l DISPOSABLE FILTER BAG 60 l	0705610003	KIT ISOLAMENTO ACUSTICO SOUNDPROOFING KIT
0075611018*	KIT BIDONE ASPIRATORE 70 l CON PULIZIA AUTOMATICA VACUUM BIN 70 l WITH AUTOMATIC CLEANING	0102611004	BRACCIO A MOLLA VERTICALE INOX S.STEEL VERTICAL BOOM
0330020006*	FILTRO CARTUCCIA CARTRIDGE FILTER	0445611057	KIT ILLUMINAZIONE LED LED LIGHT KIT
0235020005	COPERTURA GETTONIERA COIN ACCEPTOR PROTECTION	--	ETICHETTA (vedere pag. 179) LABEL (see on pag. 179)
		0445611050	DISPLAY

* A SECONDA DEL CODICE MACCHINA SCELTO
* DEPENDING ON THE SELECTED MACHINE CODE

** NECESSITA DI COLLEGAMENTO A RETE PNEUMATICA
** REQUIRES A PNEUMATIC NETWORK CONNECTION

DIMENSIONI
DIMENSIONSIMBALLO (PALLET LEGNO + PLURIBALL)
PACKAGING (WOOD PALLET + PLURIBALL)SCHEMA DI FISSAGGIO BASAMENTO
INSTALLATION SCHEME

A (mm)	B (mm)	C (mm)	X (mm)	Y (mm)	Z (mm)	D (mm)	E (mm)	F (mm)	G (mm)
592	714	1570	900	1700	800	692.5	562	570.5	440

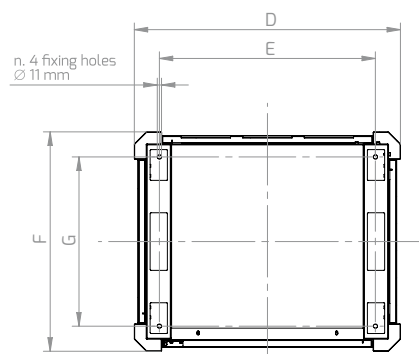
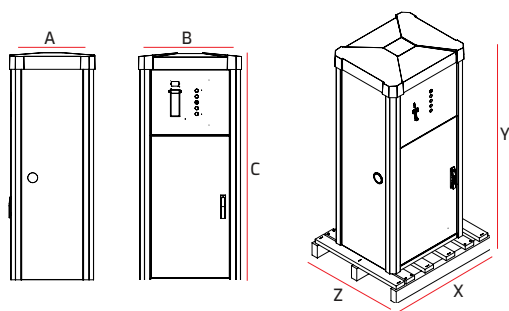



AS1-E

ASPIRATORE SELF CON RICARICA AUTO ELETTRICA INTEGRATA
 SELF VACUUM CLEANER WITH INTEGRATED ELECTRIC CAR CHARGER

MODULO DI ASPIRAZIONE/ VACUUM CLEANER MODULE

- ▲ TURBINA CON POTENZA DA 2.2 KW (TRIFASE) A 3 KW (TRIFASE) CON PORTATA D'ARIA DA 320 M³/H A 370 M³/H E DEPRESSIONE DA 2300 MM/H2O A 3300 MM/H2O
- ▲ TURBINE WITH POWER FROM 2.2 KW (THREE-PHASE) TO 3 KW (THREE-PHASE) WITH AIR FLOW FROM 320 M³/H TO 370 M³/H AND DEPRESSION FROM 2300 MM / H2O TO 3300 MM / H2O.
- ▲ BIDONE IN ACCIAIO INOX CON CAPACITÀ 70 L CON POSSIBILITÀ DI SCELTA TRA FILTRO A PERDERE, FILTRO IN POLIESTERE O FILTRO A CARTUCCIA AUTOPULENTE
- ▲ STAINLESS STEEL BIN WITH 70 L CAPACITY WITH THE POSSIBILITY OF CHOOSING AMONG A DISPOSABLE FILTER, A POLYESTER FILTER OR A SELF-CLEANING CARTRIDGE FILTER
- ▲ GETTONIERA ELETTRONICA E POSSIBILITÀ DI LETTORE CARD E/O KEY
- ▲ ELECTRONIC COIN ACCEPTOR AND POSSIBILITY OF ADDING A CARD AND /OR KEY READER
- ▲ DISPLAY OPZIONALE PER VISUALIZZAZIONE CREDITO INSERITO/ RESIDUO E TEMPO DI LAVORO RESIDUO
- ▲ OPTIONAL DISPLAY FOR CREDIT / RESIDUAL CREDIT AND REMAINING WORK TIME CHECKING

MODULO DI RICARICA AC*/ AC RECHARGE MODULE*

- ▲ PRESA STANDARD TIPO 2
- ▲ STANDARD "TYPE 2" SOCKET
- ▲ EROGAZIONE DI CORRENTE ALTERNATA
- ▲ SUPPLY OF AC
- ▲ FINE CARICA CON PULSANTE DI SBLOCCO SPINA
- ▲ END OF CHARGE WITH PLUG RELEASE BUTTON
- ▲ MODELLI INSTALLABILI: 3.7KW 16A 230VAC / 7.4KW 32A 230VAC / 11KW 16A 400VAC/22KW 32A 400VAC
- ▲ INSTALLABLE VERSIONS: 3.7KW 16A 230VAC / 7.4KW 32A 230VAC / 11KW 16A 400VAC/22KW 32A 400VAC
- ▲ CENTRALINA CONFORME ALLA RICARICA "MODO 3" DELLA NORMATIVA INTERNAZIONALE IEC/EN 61851-1
- ▲ CONTROL UNIT COMPLIANT WITH THE "MODE 3" RECHARGE OF THE INTERNATIONAL STANDARD IEC / EN 61851-1

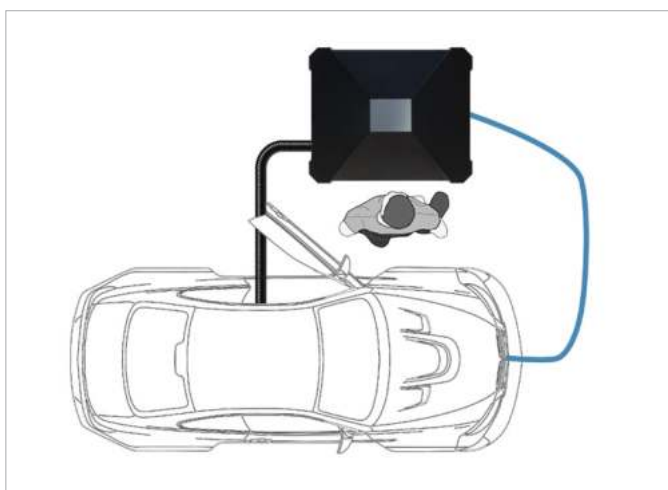

ACCESSORI IN DOTAZIONE / SUPPLIED ACCESSORIES

**TUBO FLESSIBILE Ø 40 mm LUNGHEZZA 5 m
FLEXIBLE HOSE Ø 40 mm LENGHT 5 m**

**COPERTURA GETTONIERA
COIN ACCEPTOR PROTECTION**

**KIT ACCESSORI PER TUBO FLESSIBILE
FLEXIBLE HOSE ACCESSORIES KIT**

**BIDONE E FILTRO
A SCELTA TRA
CHOOSE THE BIN
AND THE FILTER AMONG**

- KIT BIDONE ASPIRATORE
70 L FILTRO POLIESTERE
VACUUM BIN 70 L
POLYESTER FILTER**
- FILTRO POLIESTERE COMPLETO
COMPLETE POLYESTER FILTER**
- KIT BIDONE ASPIRATORE
70 L FILTRO A PERDERE
VACUUM BIN 70 L
DISPOSABLE FILTER BAG**
- SACCO FILTRO A PERDERE 60 L
DISPOSABLE FILTER BAG 60 L**
- KIT BIDONE ASPIRATORE 70 L
CON PULIZIA AUTOMATICA
VACUUM BIN 70 L WITH
AUTOMATIC CLEANING**
- FILTRO CARTUCCIA
CARTRIDGE FILTER**

QR CODE

ACCESSORI A RICHIESTA / ACCESSORIES ON DEMAND

**KIT EUROKEY NEXT
EUROKEY NEXT KIT**

**KIT ILLUMINAZIONE LED
LED LIGHT KIT**

**CASSETTO GETTONIERA LUCCHETTABILE
LOCKABLE COIN COMPARTMENT**

**KIT ISOLAMENTO ACUSTICO
SOUNDPROOFING KIT**

**BRACCIO A MOLLA VERTICALE INOX
SSTEEL VERTICAL BOOM**

DISPLAY

**ETICHETTA (vedere pag. 167)
LABEL (see on pg. 167)**

CARATTERISTICHE TECNICHE / TECHNICAL FEATURES

Codice Part No.	Potenza Power	Tensione Voltage	Portata d'Aria Air flow	Alimentazione Power Supply	Modulo di Ricarica Charging Module	Peso Totale Total Weight	Filtro Filter
3011920001	2,2 kW	400 V - 50 Hz	320 m ³ /h	400 V - 50 Hz 5 POLI R-S-T+N	22 kW - 32A	135 kg	a perdere / disposable
3011920002	2,2 kW	400 V - 50 Hz	320 m ³ /h	400 V - 50 Hz 5 POLI R-S-T+N	22 kW - 32A	135 kg	poliestere / polyester
3011920003	2,2 kW	400 V - 50 Hz	320 m ³ /h	400 V - 50 Hz 5 POLI R-S-T+N	22 kW - 32A	135 kg	automatico/automatic
3011920004	2,2 kW	400 V - 50 Hz	320 m ³ /h	400 V - 50 Hz 5 POLI R-S-T+N	11 kW - 16A	135 kg	a perdere / disposable
3011920005	2,2 kW	400 V - 50 Hz	320 m ³ /h	400 V - 50 Hz 5 POLI R-S-T+N	11 kW - 16A	135 kg	poliestere / polyester
3011920006	2,2 kW	400 V - 50 Hz	320 m ³ /h	400 V - 50 Hz 5 POLI R-S-T+N	11 kW - 16A	135 kg	automatico/automatic
3011940001	3 kW	400 V - 50 Hz	370 m ³ /h	400 V - 50 Hz 5 POLI R-S-T+N	22 kW - 32A	145 kg	a perdere / disposable
3011940002	3 kW	400 V - 50 Hz	370 m ³ /h	400 V - 50 Hz 5 POLI R-S-T+N	22 kW - 32A	145 kg	poliestere / polyester
3011940003	3 kW	400 V - 50 Hz	370 m ³ /h	400 V - 50 Hz 5 POLI R-S-T+N	22 kW - 32A	145 kg	automatico/automatic
3011940004	3 kW	400 V - 50 Hz	370 m ³ /h	400 V - 50 Hz 5 POLI R-S-T+N	11 kW - 16A	145 kg	a perdere / disposable
3011940005	3 kW	400 V - 50 Hz	370 m ³ /h	400 V - 50 Hz 5 POLI R-S-T+N	11 kW - 16A	145 kg	poliestere / polyester
3011940006	3 kW	400 V - 50 Hz	370 m ³ /h	400 V - 50 Hz 5 POLI R-S-T+N	11 kW - 16A	145 kg	automatico/automatic

ACCESSORI IN DOTAZIONE / SUPPLIED ACCESSORIES

ACCESSORI A RICHIESTA / ACCESSORIES ON DEMAND

Codice Part No.	Descrizione Description	Codice Part No.	Descrizione Description
0964550011	TUBO FLESSIBILE Ø 40 mm LUNGHEZZA 5 m FLEXIBLE HOSE Ø 40 mm LENGHT 5 m	0495022001	KIT EUROKEY NEXT EUROKEY NEXT KIT
0090611001	KIT ACCESSORI PER TUBO FLESSIBILE FLEXIBLE HOSE ACCESSORIES KIT	0705610003	KIT ISOLAMENTO ACUSTICO SOUNDPROOFING KIT
0075611017*	KIT BIDONE ASPIRATORE 70 l FILTRO POLIESTERE VACUUM BIN 70 l POLYESTER FILTER	0102611004	BRACCIO A MOLLA VERTICALE INOX S.STEEL VERTICAL BOOM
0330211002*	FILTRO POLIESTERE COMPLETO COMPLETE POLYESTERE FILTER	0445611057	KIT ILLUMINAZIONE LED LED LIGHT KIT
0075611016*	KIT BIDONE ASPIRATORE 70 l FILTRO A PERDERE VACUUM BIN 70 l DISPOSABLE FILTER BAG	--	ETICHETTA (vedere pag. 179) LABEL (see on pg. 179)
0800020001*	SACCO FILTRO A PERDERE 60 l DISPOSABLE FILTER BAG 60 l	0445611050	DISPLAY
0075611018*	KIT BIDONE ASPIRATORE 70 l CON PULIZIA AUTOMATICA VACUUM BIN 70 l WITH AUTOMATIC CLEANING		
0330020006*	FILTRO CARTUCCIA CARTRIDGE FILTER		
0235020005	COPERTURA GETTONIERA COIN ACCEPTOR PROTECTION		

* A SECONDA DEL CODICE MACCHINA SCELTO

* DEPENDING ON THE SELECTED MACHINE CODE

DIMENSIONI
DIMENSIONSIMBALLO (PALLET LEGNO + PLURIBALL)
PACKAGING (WOOD PALLET + PLURIBALL)SCHEMA DI FISSAGGIO BASAMENTO
INSTALLATION SCHEME

A (mm)	B (mm)	C (mm)	X (mm)	Y (mm)	Z (mm)	D (mm)	E (mm)	F (mm)	G (mm)
592	714	1570	900	1700	800	692.5	562	570.5	440

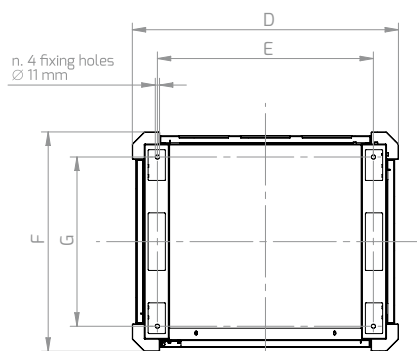
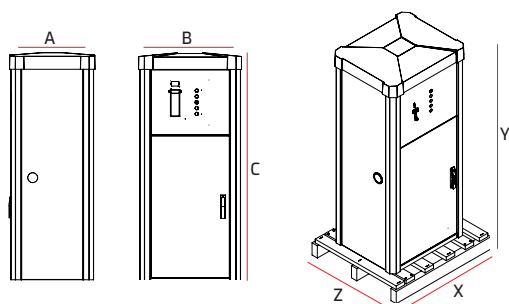



AS2

ASPIRATORE SELF DOPPIO / DOUBLE SELF VACUUM CLEANER

CARATTERISTICHE / FEATURES

- ▼ PANNELLO COMANDI SUL LATO LUNGO
- ▼ CHIUSURA A DUE PUNTI ANTIVANDALO
- ▼ ACCESSO SEPARATO AL BIDONE PER LA MANUTENZIONE ORDINARIA
- ▼ CONTENITORE GETTONI LUCCHETTABILE
- ▼ TEMPO CICLO PROGRAMMABILE
- ▼ AVVIAMENTO MANUALE A RICHIESTA
- ▼ CALOTTA IN ABS RESISTENTE AI RAGGI UV
- ▼ INNOVATIVO SISTEMA DI RAFFREDDAMENTO DELLA TURBINA
- ▼ QUADRO ELETTRICO E GETTONIERA ELETTRONICA INTEGRATI E DI FACILE ACCESSO
- ▼ CONTROL PANEL ON THE LONG SIDE
- ▼ VANDAL-PROOF DOORS AND LOCKS
- ▼ SEPARATE ACCESS TO CONTAINER FOR ORDINARY MAINTENANCE
- ▼ LOCKABLE TOKEN/COIN COMPARTMENT
- ▼ PROGRAMMABLE CYCLE TIME
- ▼ MANUAL START ON DEMAND
- ▼ ABS COVER, RESISTANT TO UV RAYS
- ▼ REVOLUTIONARY INTERNAL COOLING SYSTEM
- ▼ EASY ACCESS INTEGRATED ELECTRONIC CONTROL BOARD

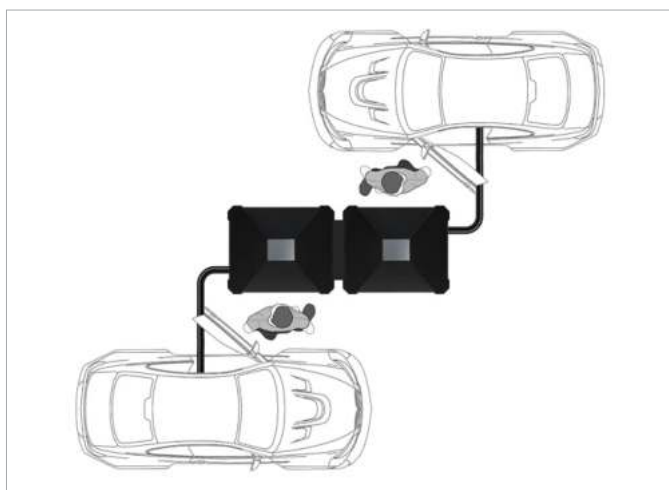

ACCESSORI IN DOTAZIONE / SUPPLIED ACCESSORIES

**TUBO FLESSIBILE Ø 40 mm LUNGHEZZA 5 m
FLEXIBLE HOSE Ø 40 mm LENGHT 5 m**

**KIT ACCESSORI PER TUBO FLESSIBILE
FLEXIBLE HOSE ACCESSORIES KIT**

**COPERTURA GETTONIERA
COIN ACCEPTOR PROTECTION**

**BIDONE E FILTRO
A SCELTA TRA
CHOOSE THE BIN
AND THE FILTER AMONG**

- KIT BIDONE ASPIRATORE
70 L FILTRO POLIESTERE
VACUUM BIN 70 L
POLYESTER FILTER**
- FILTRO POLIESTERE COMPLETO
COMPLETE POLYESTER FILTER**
- KIT BIDONE ASPIRATORE
70 L FILTRO A PERDERE
VACUUM BIN 70 L
DISPOSABLE FILTER BAG**
- SACCO FILTRO A PERDERE 60 L
DISPOSABLE FILTER BAG 60 L**
- KIT BIDONE ASPIRATORE 70 L
CON PULIZIA AUTOMATICA
VACUUM BIN 70 L WITH
AUTOMATIC CLEANING**
- FILTRO CARTUCCIA
CARTRIDGE FILTER**

QR CODE

ACCESSORI A RICHIESTA / ACCESSORIES ON DEMAND

**BRACCIO A MOLLA VERTICALE INOX
S.STEEL VERTICAL BOOM**

**KIT EUROKEY NEXT
EUROKEY NEXT KIT**

DISPLAY

**KIT ARIA COMPRESSA
COMPRESSED AIR KIT**

**KIT ILLUMINAZIONE LED
LED LIGHT KIT**

**KIT ISOLAMENTO ACUSTICO
SOUNDPROOFING KIT**

**KIT SOFFIAGGIO ARIA
BLOWING AIR KIT**

**ETICHETTA (vedere pag. 167)
LABEL (see on pg. 167)**

**KIT NEBULIZZATORE
SPRAY KIT**

**KIT NEROGOMME
TIRE BLACKENING KIT**

CARATTERISTICHE TECNICHE / TECHNICAL FEATURES

Codice Part No.	Potenza Power	Tensione Voltage	Portata d'Aria Air flow	Alimentazione Power Supply	Peso Totale Total Weight	Filtro Filter
3010330001	2 x 2,2 kW	230 V - 50 Hz	320 m ³ /h	230 V - 50 Hz	250 kg	a perdere / disposable
3010330002	2 x 2,2 kW	230 V - 50 Hz	320 m ³ /h	230 V - 50 Hz	250 kg	poliestere / polyester
3010410001	2 x 2,2 kW	230 V - 50 Hz	320 m ³ /h	230 V - 50 Hz	250 kg	automatico / automatic
3010320001	2 x 2,2 kW	400 V - 50 Hz	320 m ³ /h	400 V - 50 Hz 5 POLI R-S-T+N	250 kg	a perdere / disposable
3010320002	2 x 2,2 kW	400 V - 50 Hz	320 m ³ /h	400 V - 50 Hz 5 POLI R-S-T+N	250 kg	poliestere / polyester
3010420001	2 x 2,2 kW	400 V - 50 Hz	320 m ³ /h	400 V - 50 Hz 5 POLI R-S-T+N	250 kg	automatico / automatic
3010340001	2 x 3 kW	400 V - 50 Hz	370 m ³ /h	400 V - 50 Hz 5 POLI R-S-T+N	270 kg	a perdere / disposable
3010340002	2 x 3 kW	400 V - 50 Hz	370 m ³ /h	400 V - 50 Hz 5 POLI R-S-T+N	270 kg	poliestere / polyester
3010440001	2 x 3 kW	400 V - 50 Hz	370 m ³ /h	400 V - 50 Hz 5 POLI R-S-T+N	270 kg	automatico / automatic

ACCESSORI IN DOTAZIONE / SUPPLIED ACCESSORIES

Codice (1 pz.) Part No. (1 piece)	Descrizione Description	Quantità Quantity
0964550011	TUBO FLESSIBILE Ø 40 mm LUNGHEZZA 5 m FLEXIBLE HOSE Ø 40 mm LENGHT 5 m	2
0090611001	KIT ACCESSORI PER TUBO FLESSIBILE FLEXIBLE HOSE ACCESSORIES KIT	2
0075611017*	KIT BIDONE ASPIRATORE 70 l FILTRO POLIESTERE VACUUM BIN 70 l POLYESTER FILTER	2
0330211002*	FILTRO POLIESTERE COMPLETO COMPLETE POLYESTERE FILTER	2
0075611016*	KIT BIDONE ASPIRATORE 70 l FILTRO A PERDERE VACUUM BIN 70 l DISPOSABLE FILTER BAG	2
0800020001*	SACCO FILTRO A PERDERE 60 l DISPOSABLE FILTER BAG 60 l	2
0075611018*	KIT BIDONE ASPIRATORE 70 l CON PULIZIA AUTOMATICA VACUUM BIN 70 l WITH AUTOMATIC CLEANING	2
0330020006*	FILTRO CARTUCCIA CARTRIDGE FILTER	2
0235020005	COPERTURA GETTONIERA COIN ACCEPTOR PROTECTION	2

* A SECONDA DEL CODICE MACCHINA SCELTO
* DEPENDING ON THE SELECTED MACHINE CODE

** NECESSITA DI COLLEGAMENTO A RETE PNEUMATICA
** REQUIRES A PNEUMATIC NETWORK CONNECTION

ACCESSORI A RICHIESTA / ACCESSORIES ON DEMAND

Codice Part No.	Descrizione Description
0445611009	KIT NEBULIZZATORE SPRAY KIT
0445611010**	KIT ARIA COMPRESSA COMPRESSED AIR KIT
0445611008	KIT NEROGOMME TIRE BLACKENING KIT
0445611024	KIT SOFFIAGGIO ARIA AIR BLOWING KIT
0495022001	KIT EUROKEY NEXT EUROKEY NEXT KIT
0705610003	KIT ISOLAMENTO ACUSTICO SOUNDPROOFING KIT
0102611004	BRACCIO A MOLLA VERTICALE INOX S.STEEL VERTICAL BOOM
0445611057	KIT ILLUMINAZIONE LED LED LIGHT KIT
--	ETICHETTA (vedere pag. 179) LABEL (see on pag. 179)
0445611050	DISPLAY

DIMENSIONI
DIMENSIONSIMBALLO (PALLET LEGNO + PLURIBALL)
PACKAGING (WOOD PALLET + PLURIBALL)SCHEMA DI FISSAGGIO BASAMENTO
INSTALLATION SCHEME

A (mm)	B (mm)	C (mm)	X (mm)	Y (mm)	Z (mm)	D (mm)	E (mm)	F (mm)	G (mm)	H (mm)	I (mm)
592	1526	1570	1755	1700	800	562	250	562	1505	440	570.5

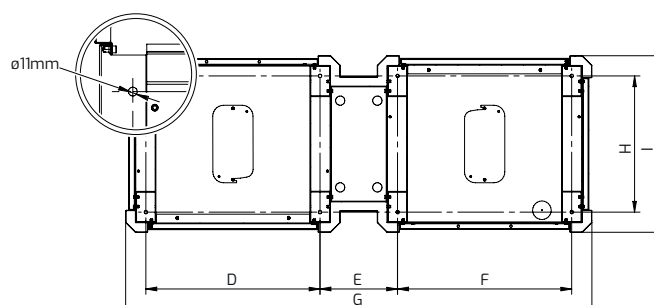
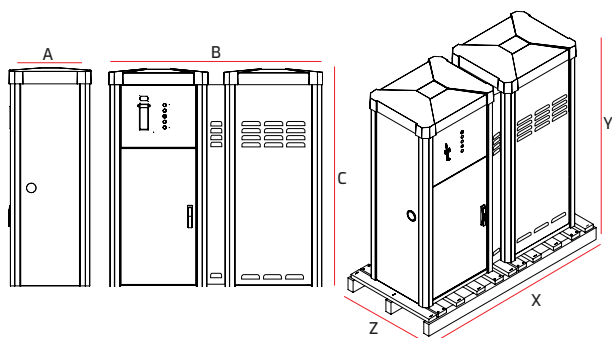



AF1 - AF1 AIR - AF1 AIR PLUS

ASPIRATORE SELF SINGOLO / SINGLE SELF VACUUM CLEANER

CARATTERISTICHE / FEATURES

- CHIUSURA A DUE PUNTI ANTIVANDALO
- TEMPO CICLO PROGRAMMABILE
- QUADRO ELETTRICO E GETTONIERA INTEGRATE E DI FACILE ACCESSO
- AVVIAMENTO MANUALE A RICHIESTA
- CALOTTA IN ABS RESISTENTE AI RAGGI UV
- APERTURA TOTALE FRONTALE CON SPORTELLO COMANDI INCERNIERATO
- NUOVI BIDONI IN ACCIAIO INOX
- A RICHIESTA TURBINA 2,2 kW (230V-50Hz)
- KIT ARIA COMPRESSA INCLUSO, NECESSITA DI COLLEGAMENTO A RETE PNEUMATICA (AF1 AIR - AF1 AIR PLUS)
- A RICHIESTA KIT SOFFIAGGIO ARIA (DOVE NON RAGGIUNTI DA RETE ARIA COMPRESSA)
- KIT NEBULIZZATORE INCLUSO (AF1 AIR PLUS)
- VANDAL-PROOF DOORS AND LOCKS
- PROGRAMMABLE CYCLE TIME
- EASY ACCESS INTEGRATED ELECTRONIC CONTROL BOARD
- MANUAL START ON DEMAND
- ABS COVER, RESISTANT TO UV RAYS
- TOTAL FRONT OPENING WITH HINGED CONTROL DOOR
- NEW STAINLESS STEEL BINS
- 2,2 kW TURBINE ON DEMAND (230V-50Hz)
- COMPRESSED AIR KIT ALWAYS SUPPLIED, REQUIRES A PNEUMATIC NETWORK CONNECTION (AF1 AIR - AF1 AIR PLUS)
- BLOWING AIR KIT ON DEMAND (WHERE NOT REACHED BY COMPRESSED AIR SYSTEM)
- SPRAY KIT INCLUDED (AF1 AIR PLUS)

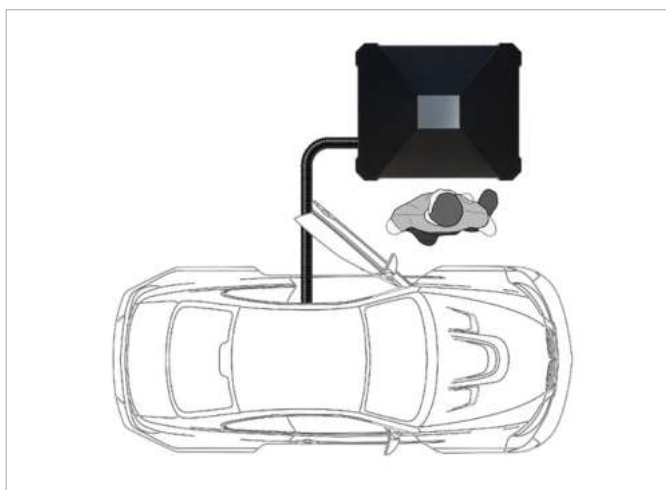

ACCESSORI IN DOTAZIONE / SUPPLIED ACCESSORIES



ACCESSORI A RICHIESTA / ACCESSORIES ON DEMAND



ACCESSORI IN DOTAZIONE / SUPPLIED ACCESSORIES

**TUBO FLESSIBILE Ø 40 mm LUNGHEZZA 5 m
FLEXIBLE HOSE Ø 40 mm LENGHT 5 m**

**COPERTURA GETTONIERA
COIN ACCEPTOR PROTECTION**

**KIT ACCESSORI PER TUBO FLESSIBILE
FLEXIBLE HOSE ACCESSORIES KIT**

**KIT ARIA COMPRESSA
COMPRESSED AIR KIT**

**BIDONE E FILTRO
A SCELTA TRA
CHOOSE THE BIN
AND THE FILTER AMONG**

**KIT BIDONE ASPIRATORE
55 L FILTRO POLIESTERE
VACUUM BIN 55 L
POLYESTER FILTER**

**FILTRO POLIESTERE COMPLETO
COMPLETE POLYESTER FILTER**

**KIT BIDONE ASPIRATORE
55 L FILTRO A PERDERE
VACUUM BIN 55 L
DISPOSABLE FILTER BAG**

**SACCO FILTRO A PERDERE 30 L
DISPOSABLE FILTER BAG 30 L**

**KIT BIDONE ASPIRATORE 55 L
CON PULIZIA AUTOMATICA
VACUUM BIN 55 L WITH
AUTOMATIC CLEANING**

**FILTRO CARTUCCIA
CARTRIDGE FILTER**

ACCESSORI A RICHIESTA / ACCESSORIES ON DEMAND

**BRACCIO A MOLLA VERTICALE INOX
S.S. STEEL VERTICAL BOOM**

**ETICHETTA (vedere pag. 167)
LABEL (see on pg. 167)**

**KIT ANTISCASSO
ARMOR KIT**

DISPLAY

**KIT EUROKEY NEXT
EUROKEY NEXT KIT**

**KIT ILLUMINAZIONE LED
LED LIGHT KIT**

**CASSETTO GETTONIERA LUCCHETTABILE
LOCKABLE COIN COMPARTMENT**

ACCESSORI IN DOTAZIONE / SUPPLIED ACCESSORIES

TUBO FLESSIBILE Ø 40 mm LUNGHEZZA 5 m
FLEXIBLE HOSE Ø 40 mm LENGHT 5 m

KIT ACCESSORI PER TUBO FLESSIBILE
FLEXIBLE HOSE ACCESSORIES KIT

KIT ARIA COMPRESSA
COMPRESSED AIR KIT

KIT NEBULIZZATORE
SPRAY KIT

COPERTURA GETTONIERA
COIN ACCEPTOR PROTECTION

BIDONE E FILTRO
A SCELTA TRA
CHOOSE THE BIN
AND THE FILTER AMONG

KIT BIDONE ASPIRATORE
55 L FILTRO POLIESTERE
VACUUM BIN 55 L
POLYESTER FILTER

FILTRO POLIESTERE COMPLETO
COMPLETE POLYESTER FILTER

KIT BIDONE ASPIRATORE
55 L FILTRO A PERDERE
VACUUM BIN 55 L
DISPOSABLE FILTER BAG

SACCO FILTRO A PERDERE 30 L
DISPOSABLE FILTER BAG 30 L

KIT BIDONE ASPIRATORE 55 L
CON PULIZIA AUTOMATICA
VACUUM BIN 55 L WITH
AUTOMATIC CLEANING

FILTRO CARTUCCIA
CARTRIDGE FILTER

ACCESSORI A RICHIESTA / ACCESSORIES ON DEMAND

ETICHETTA (vedere pag. 167)
LABEL (see on pg. 167)

BRACCIO A MOLLA VERTICALE INOX
SSTEEL VERTICAL BOOM

DISPLAY

KIT ANTISCASSO
ARMOR KIT

KIT EUROKEY NEXT
EUROKEY NEXT KIT

KIT ANTIGELO
NO FROST KIT

CASSETTO GETTONIERA LUCCHETTABILE
LOCKABLE COIN COMPARTMENT

KIT ILLUMINAZIONE LED
LED LIGHT KIT

CARATTERISTICHE TECNICHE / TECHNICAL FEATURES

Codice Part No.	Modello Model	Potenza Power	Tensione Voltage	Portata d'Aria Air flow	Alimentazione Power Supply	Peso Totale Total Weight	Filtro Filter
3011420101	AF1	2,2 kW	400 V - 50 Hz	320 m ³ /h	400 V - 50 Hz 5 POLI R-S-T+N	90 kg	a perdere / disposable
3011420102	AF1	2,2 kW	400 V - 50 Hz	320 m ³ /h	400 V - 50 Hz 5 POLI R-S-T+N	90 kg	poliestere / polyester
3011520101	AF1	2,2 kW	400 V - 50 Hz	320 m ³ /h	400 V - 50 Hz 5 POLI R-S-T+N	90 kg	automatico / automatic
3011420103	AF1 AIR	2,2 kW	400 V - 50 Hz	320 m ³ /h	400 V - 50 Hz 5 POLI R-S-T+N	91 kg	a perdere / disposable
3011420104	AF1 AIR	2,2 kW	400 V - 50 Hz	320 m ³ /h	400 V - 50 Hz 5 POLI R-S-T+N	91 kg	poliestere / polyester
3011520102	AF1 AIR	2,2 kW	400 V - 50 Hz	320 m ³ /h	400 V - 50 Hz 5 POLI R-S-T+N	91 kg	automatico / automatic
3011420105	AF1 AIR PLUS	2,2 kW	400 V - 50 Hz	320 m ³ /h	400 V - 50 Hz 5 POLI R-S-T+N	92 kg	a perdere / disposable
3011420106	AF1 AIR PLUS	2,2 kW	400 V - 50 Hz	320 m ³ /h	400 V - 50 Hz 5 POLI R-S-T+N	92 kg	poliestere / polyester
3011520103	AF1 AIR PLUS	2,2 kW	400 V - 50 Hz	320 m ³ /h	400 V - 50 Hz 5 POLI R-S-T+N	92 kg	automatico / automatic

ACCESSORI IN DOTAZIONE / SUPPLIED ACCESSORIES

Codice Part No.	Modello Model	Descrizione Description
0964550011	TUTTI ALL	TUBO FLESSIBILE Ø 40 mm LUNGHEZZA 5 m FLEXIBLE HOSE Ø 40 mm LENGHT 5 m
0090611001	TUTTI ALL	KIT ACCESSORI PER TUBO FLESSIBILE FLEXIBLE HOSE ACCESSORIES KIT
0075611019*	TUTTI ALL	KIT BIDONE ASPIRATORE 55 L FILTRO POLIESTERE VACUUM BIN 55 L POLYESTER FILTER
0330211002*	TUTTI ALL	FILTRO POLIESTERE COMPLETO COMPLETE POLYESTERE FILTER
0075611021*	TUTTI ALL	KIT BIDONE ASPIRATORE 55 L FILTRO A PERDERE VACUUM BIN 55 L DISPOSABLE FILTER BAG
0800020002*	TUTTI ALL	SACCO FILTRO A PERDERE 30 L DISPOSABLE FILTER BAG 30 L
0075611020*	TUTTI ALL	KIT BIDONE ASPIRATORE 55 L CON PULIZIA AUTOMATICA VACUUM BIN 55 L WITH AUTOMATIC CLEANING
0330020006*	TUTTI ALL	FILTRO CARTUCCIA CARTRIDGE FILTER
0235020005	TUTTI ALL	COPERTURA GETTONIERA COIN ACCEPTOR PROTECTION
0445611030***	AF1 AIR AF1 AIR PLUS	KIT ARIA COMPRESSA COMPRESSED AIR KIT
0445611029	AF1 AIR PLUS	KIT NEBULIZZATORE SPRAY KIT

* A SECONDA DEL CODICE MACCHINA SCELTO
* DEPENDING ON THE SELECTED MACHINE CODE

*** NECESSITA DI COLLEGAMENTO A RETE PNEUMATICA
*** REQUIRES A PNEUMATIC NETWORK CONNECTION

ACCESSORI A RICHIESTA / ACCESSORIES ON DEMAND

Codice Part No.	Modello Model	Descrizione Description
0495022001	TUTTI ALL	KIT EUROKEY NEXT EUROKEY NEXT KIT
0445611047	TUTTI ALL	KIT ILLUMINAZIONE LED LED LIGHT KIT
0170242011	TUTTI ALL	CASSETTO GETTONIERA LUCCHETTABILE LOCKABLE COIN COMPARTMENT
--	TUTTI ALL	ETICHETTA (vedere pag. 179) LABEL (see on pg. 179)
0102611002	TUTTI ALL	BRACCIO A MOLLA VERTICALE INOX SSTEEL VERTICAL BOOM
0445611048	AF1 AIR PLUS	KIT ANTIGELO NO FROST KIT
0445611113	AF1	KIT SOFFIAGGIO ARIA AIR BLOWING KIT
0445611100	TUTTI ALL	KIT ANTISCASSO ARMOR KIT
0445611050	TUTTI ALL	DISPLAY

DIMENSIONI
DIMENSIONSIMBALLO (PALLET LEGNO + PLURIBALL)
PACKAGING (WOOD PALLET + PLURIBALL)SCHEMA DI FISSAGGIO BASAMENTO
INSTALLATION SCHEME

A (mm)	B (mm)	C (mm)	X (mm)	Y (mm)	Z (mm)	D (mm)	E (mm)
592	714	1448	900	1578	800	453	600

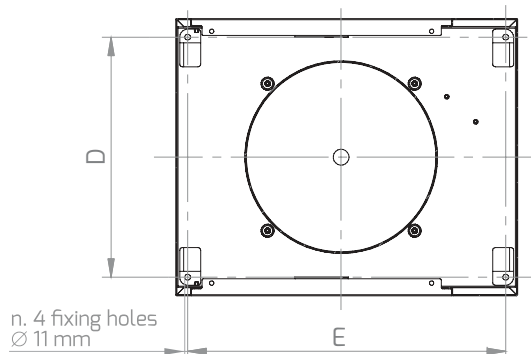
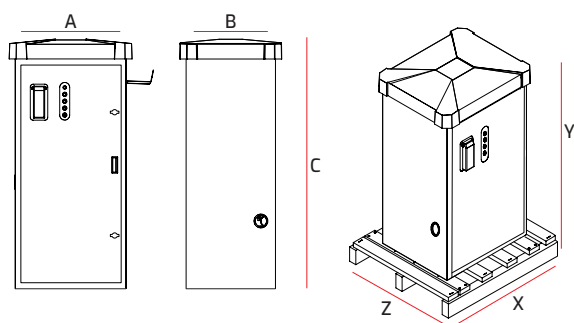

INOX
304

AF2

AF2 AIR

AF2 AIR PLUS

AF2 - AF2 AIR - AF2 AIR PLUS

ASPIRATORE SELF DOPPIO / DOUBLE SELF VACUUM CLEANER

NEW

CARATTERISTICHE / FEATURES

- ▲ PANNELLO COMANDI SUL LATO LUNGO
- ▲ CHIUSURA A DUE PUNTI ANTIVANDALO
- ▲ TEMPO CICLO PROGRAMMABILE
- ▲ AVVIAMENTO MANUALE A RICHIESTA
- ▲ CALOTTA IN ABS RESISTENTE AI RAGGI UV
- ▲ SPORTELLI ANTERIORI E POSTERIORI FACILMENTE RIMOVIBILI PER INTERVENTI DI MANUTENZIONE
- ▲ NUOVI BIDONI IN ACCIAIO INOX
- ▲ A RICHIESTA TURBINA 2 x 1,5 kW (230V-50Hz/400V - 50Hz)
- ▲ KIT ARIA COMPRESSA INCLUSO, NECESSITA DI COLLEGAMENTO A RETE PNEUMATICA (AF2 AIR - AF2 AIR PLUS)
- ▲ KIT NEBULIZZATORE INCLUSO (AF2 AIR PLUS)
- ▲ CONTROL PANEL ON THE LONG SIDE
- ▲ VANDAL-PROOF DOORS AND LOCKS
- ▲ PROGRAMMABLE CYCLE TIME
- ▲ MANUAL START ON DEMAND
- ▲ ABS COVER, RESISTANT TO UV RAYS
- ▲ FRONT AND REAR COVER PANELS EASY TO REMOVE FOR MAINTENANCE OPERATIONS
- ▲ NEW STAINLESS STEEL BINS
- ▲ 2 x 1,5 kW TURBINE ON DEMAND (230V-50Hz/400V - 50Hz)
- ▲ COMPRESSED AIR KIT ALWAYS SUPPLIED, REQUIRES A PNEUMATIC NETWORK CONNECTION (AF2 AIR - AF2 AIR PLUS)
- ▲ SPRAY KIT INCLUDED (AF2 AIR PLUS)

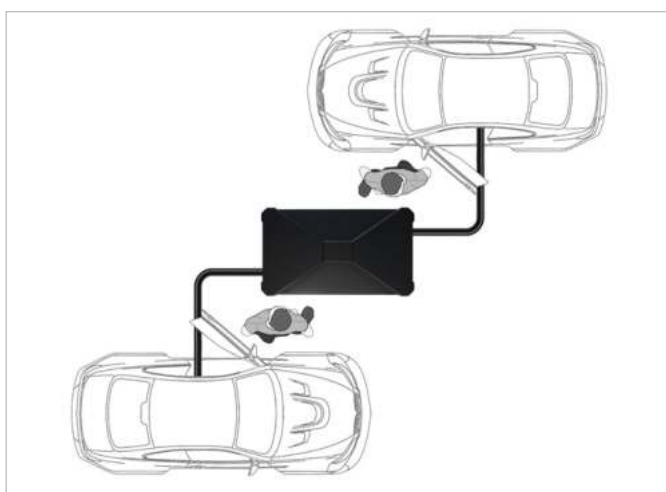

ACCESSORI IN DOTAZIONE / SUPPLIED ACCESSORIES

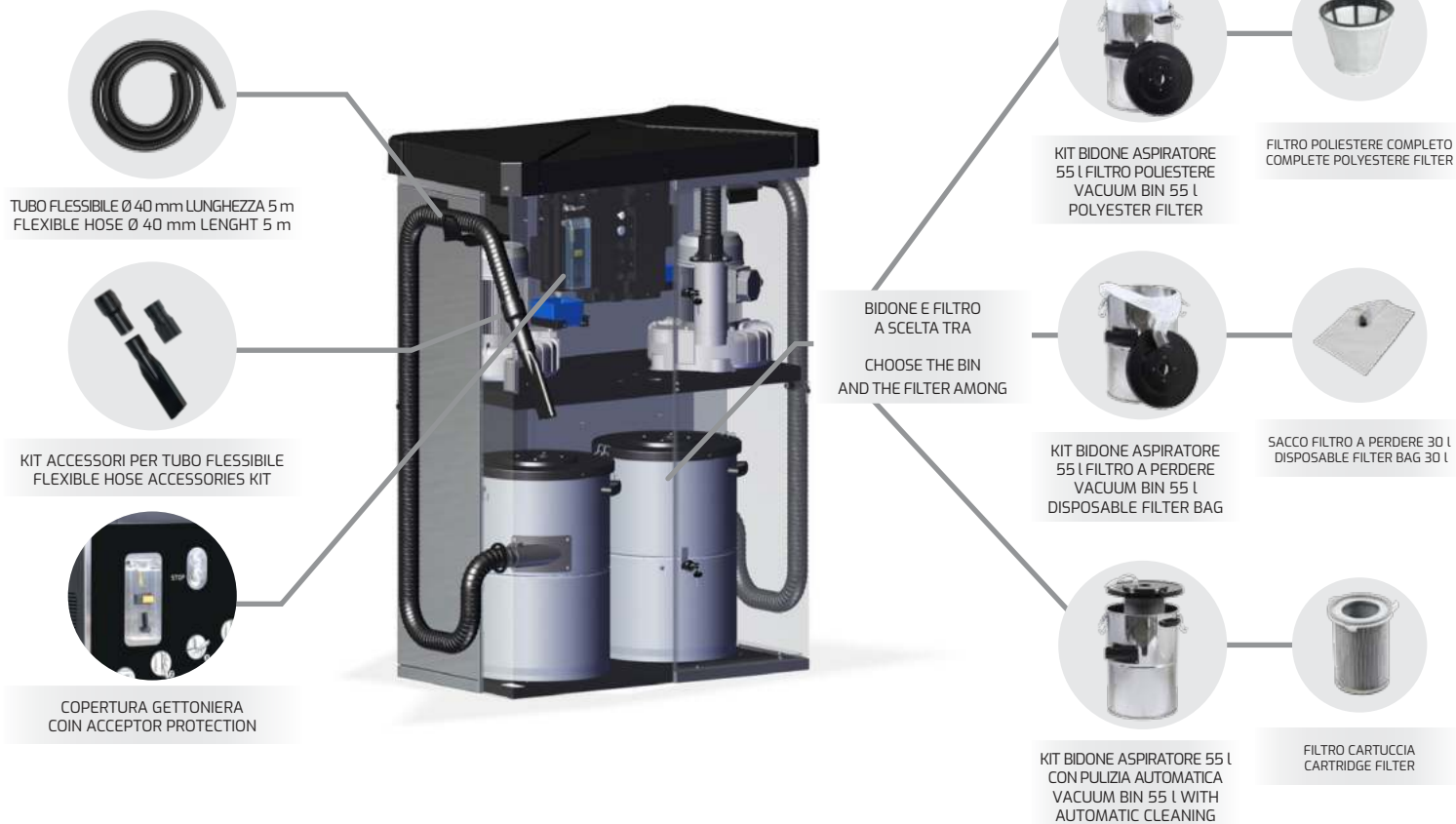

ACCESSORI A RICHIESTA / ACCESSORIES ON DEMAND

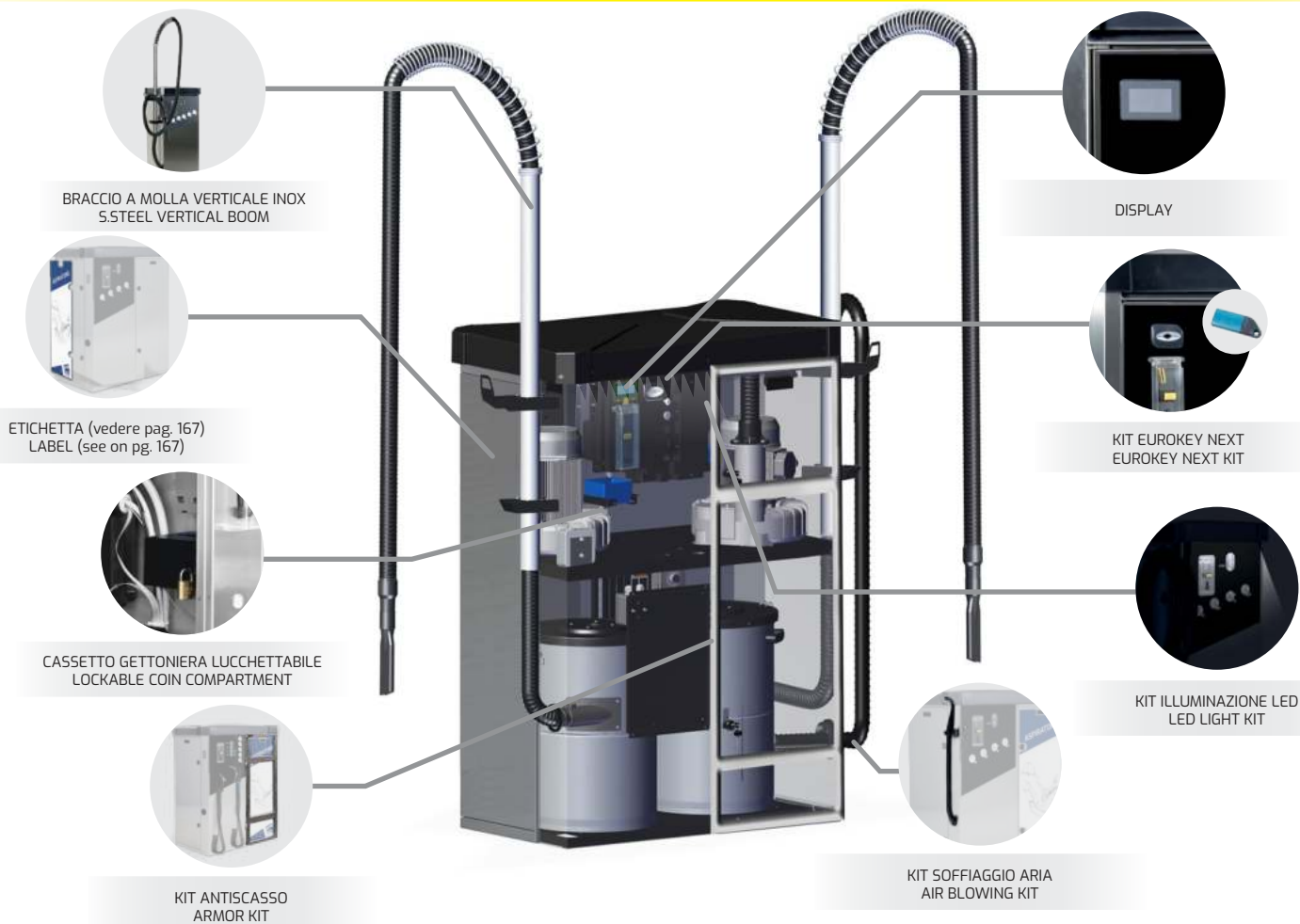

ACCESSORI IN DOTAZIONE / SUPPLIED ACCESSORIES

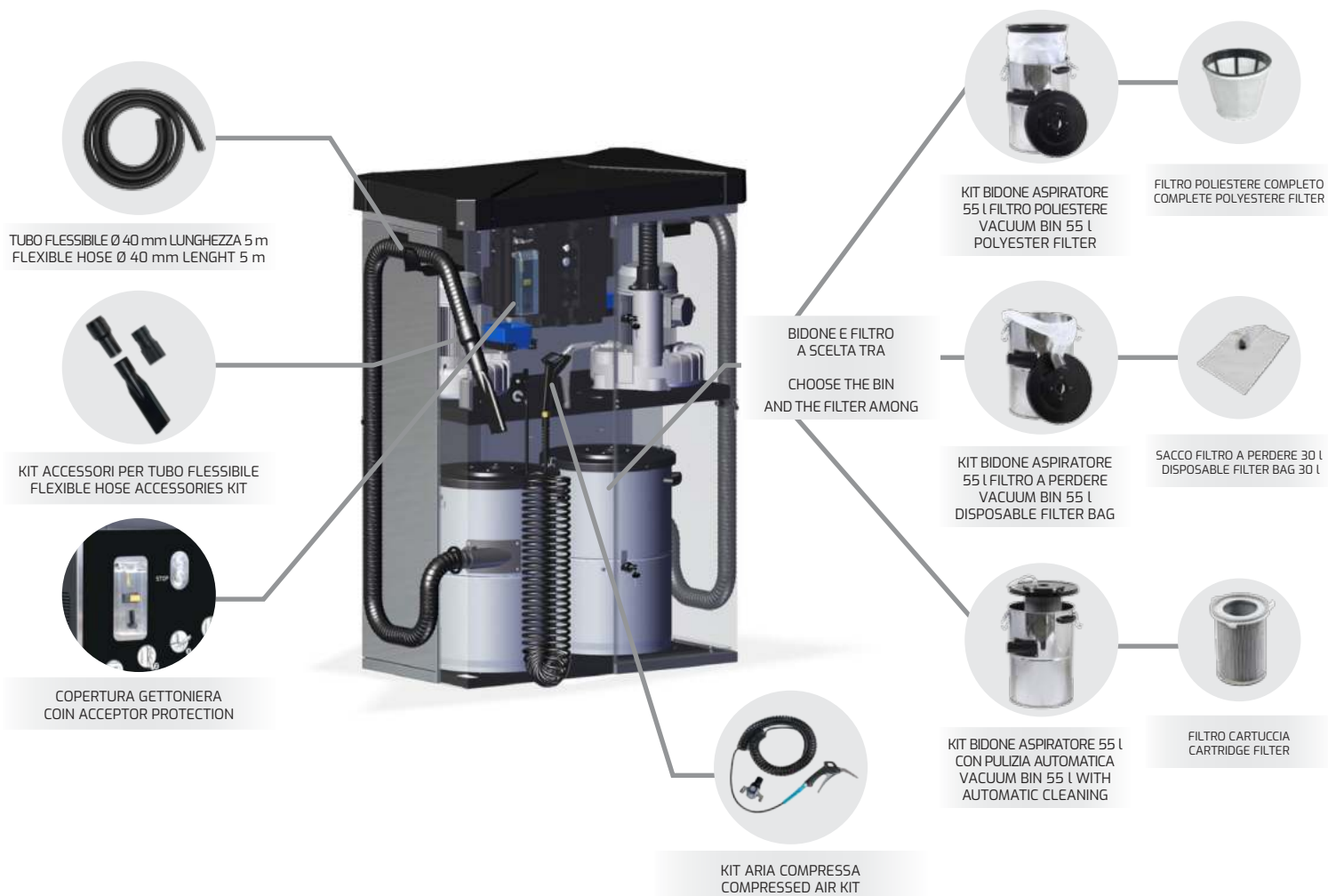

ACCESSORI A RICHIESTA / ACCESSORIES ON DEMAND

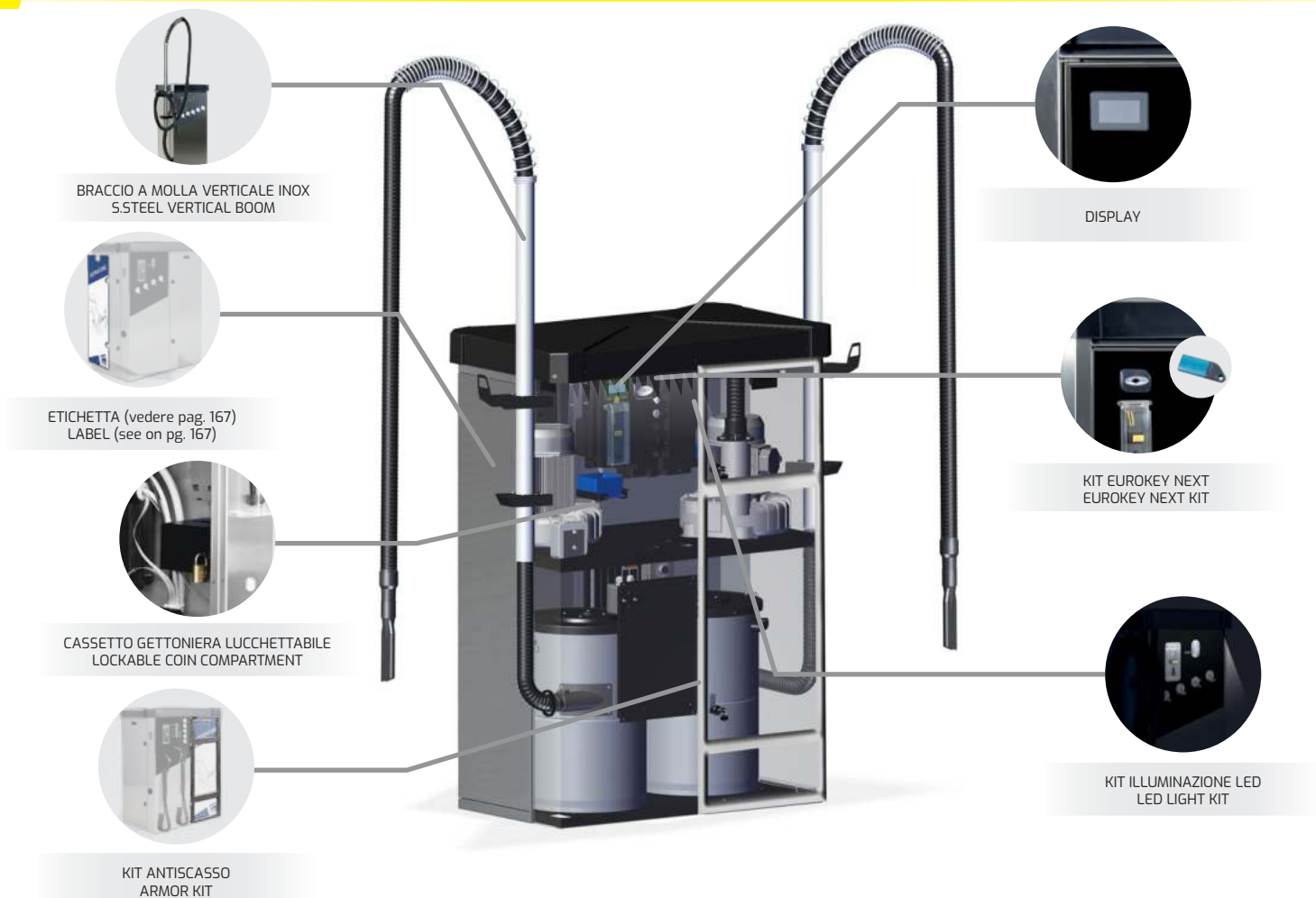

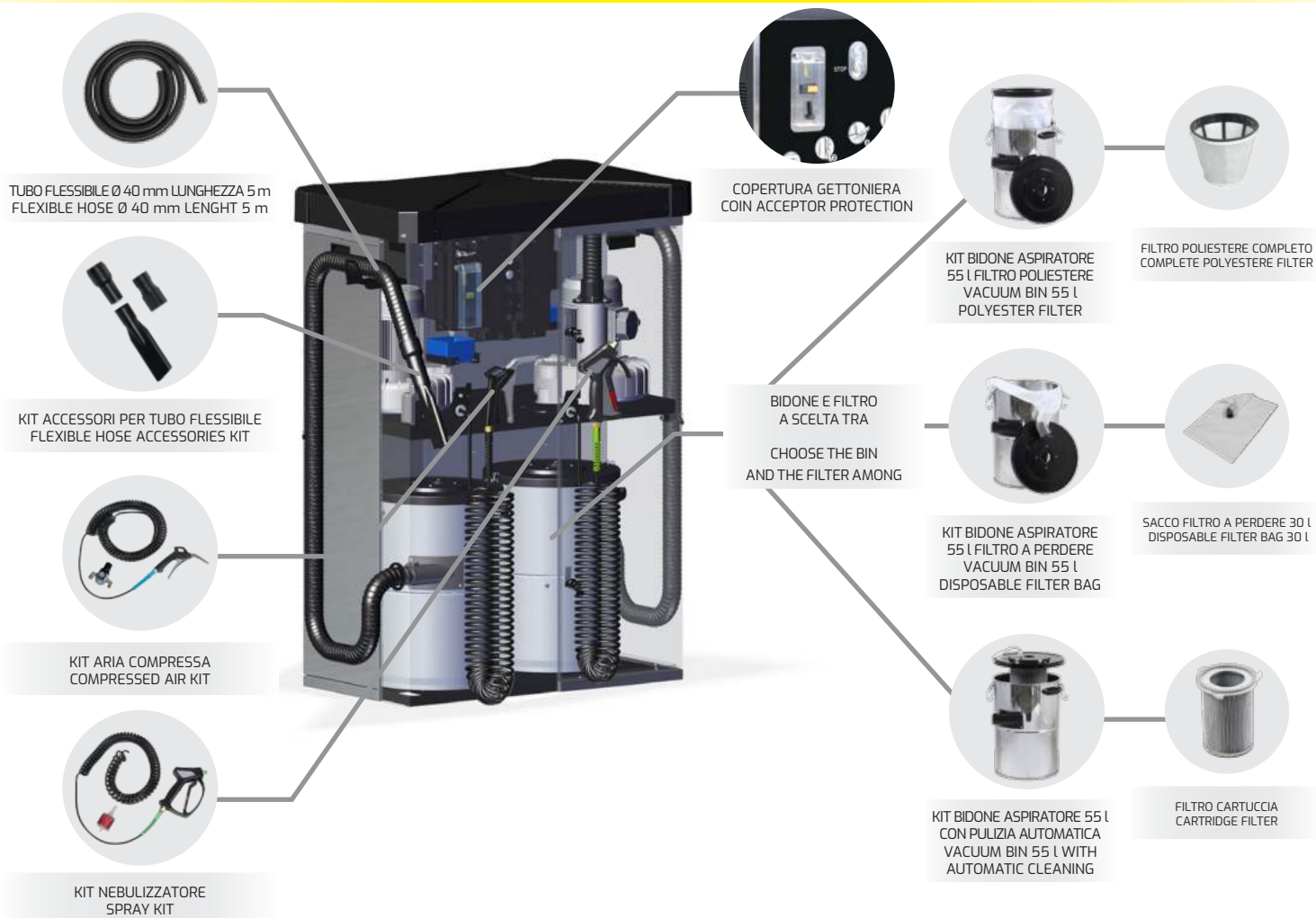

ACCESSORI A RICHIESTA / ACCESSORIES ON DEMAND



CARATTERISTICHE TECNICHE / TECHNICAL FEATURES

Codice Part No.	Modello Model	Potenza Power	Tensione Voltage	Portata d'Aria Air flow	Alimentazione Power Supply	Peso Totale Total Weight	Filtro Filter
3011720101	AF2	2 x 2,2 kW	400V	320 m ³ /h	400V - 50 Hz	130 kg	a perdere / disposable
3011720102	AF2	2 x 2,2 kW	400V	320 m ³ /h	400V - 50 Hz	130 kg	poliestere / polyester
3011820101	AF2	2 x 2,2 kW	400V	320 m ³ /h	400V - 50 Hz	130 kg	autopulente / automatic
3011720103	AF2 AIR	2 x 2,2 kW	400V	320 m ³ /h	400V - 50 Hz	130 kg	a perdere / disposable
3011720104	AF2 AIR	2 x 2,2 kW	400V	320 m ³ /h	400V - 50 Hz	130 kg	poliestere / polyester
3011820102	AF2 AIR	2 x 2,2 kW	400V	320 m ³ /h	400V - 50 Hz	130 kg	autopulente / automatic
3011720105	AF2 AIR PLUS	2 x 2,2 kW	400V	320 m ³ /h	400V - 50 Hz	130 kg	a perdere / disposable
3011720106	AF2 AIR PLUS	2 x 2,2 kW	400V	320 m ³ /h	400V - 50 Hz	130 kg	poliestere / polyester
3011820103	AF2 AIR PLUS	2 x 2,2 kW	400V	320 m ³ /h	400V - 50 Hz	130 kg	autopulente / automatic

ACCESSORI IN DOTAZIONE / SUPPLIED ACCESSORIES

Codice Part No.	Modello Model	Descrizione Description
0964550011	TUTTI ALL	TUBO FLESSIBILE Ø 40 mm LUNGHEZZA 5 m FLEXIBLE HOSE Ø 40 mm LENGTH 5 m
0090611001	TUTTI ALL	KIT ACCESSORI PER TUBO FLESSIBILE FLEXIBLE HOSE ACCESSORIES KIT
0075611019*	TUTTI ALL	KIT BIDONE ASPIRATORE 55 l FILTRO POLIESTERE VACUUM BIN 55 l POLYESTER FILTER
0330211002*	TUTTI ALL	FILTRO POLIESTERE COMPLETO COMPLETE POLYESTER FILTER
0075611021*	TUTTI ALL	KIT BIDONE ASPIRATORE 55 l FILTRO A PERDERE VACUUM BIN 55 l DISPOSABLE FILTER BAG
0800020002*	TUTTI ALL	SACCO FILTRO A PERDERE 30 l DISPOSABLE FILTER BAG 30 l
0075611020*	TUTTI ALL	KIT BIDONE ASPIRATORE 55 l CON PULIZIA AUTOMATICA VACUUM BIN 55 l WITH AUTOMATIC CLEANING
0330020006	TUTTI ALL	FILTRO CARTUCCIA CARTRIDGE FILTER
0235020005	TUTTI ALL	COPERTURA GETTONIERA COIN ACCEPTOR PROTECTION
0445611030**	AF2 AIR AF2 AIR PLUS	KIT ARIA COMPRESSA COMPRESSED AIR KIT
0445611029	AF2 AIR PLUS	KIT NEBULIZZATORE SPRAY KIT

* A SECONDA DEL CODICE MACCHINA SCELTO
* DEPENDING ON THE SELECTED MACHINE CODE

** NECESSITA DI COLLEGAMENTO A RETE PNEUMATICA
** REQUIRES A PNEUMATIC NETWORK CONNECTION

ACCESSORI A RICHIESTA / ACCESSORIES ON DEMAND

Codice Part No.	Modello Model	Descrizione Description
0495022001	TUTTI ALL	KIT EUROKEY NEXT EUROKEY NEXT KIT
0445611047	TUTTI ALL	KIT ILLUMINAZIONE LED LED LIGHT KIT
0170242011	TUTTI ALL	CASSETTO GETTONIERA LUCCHETTABILE LOCKABLE COIN COMPARTMENT
--	TUTTI ALL	ETICHETTA (vedere pag. 179) LABEL (see on pg. 179)
0102611002	TUTTI ALL	BRACCIO A MOLLA VERTICALE INOX S.STEEL VERTICAL BOOM
0445611048	AF2 AIR PLUS	KIT ANTIGELO NO FROST KIT
0445611113	AF2	KIT SOFFIAGGIO ARIA AIR BLOWING KIT
0445611115	TUTTI ALL	KIT ANTISCASSO ARMOR KIT
0445611050	TUTTI ALL	DISPLAY

DIMENSIONI
DIMENSIONSIMBALLO (PALLET LEGNO + PLURIBALL)
PACKAGING (WOOD PALLET + PLURIBALL)SCHEMA DI FISSAGGIO BASAMENTO
INSTALLATION SCHEME

A (mm)	B (mm)	C (mm)	X (mm)	Y (mm)	Z (mm)	D (mm)	E (mm)
592	1019	1448	1150	1578	600	905	453

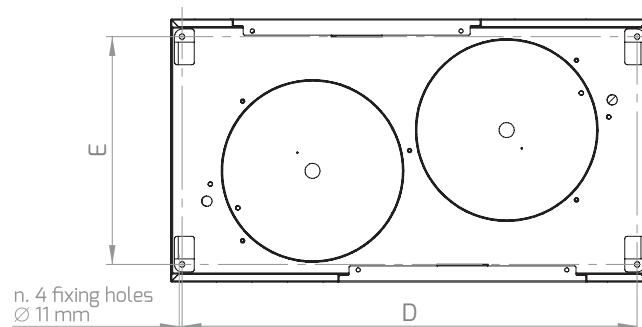
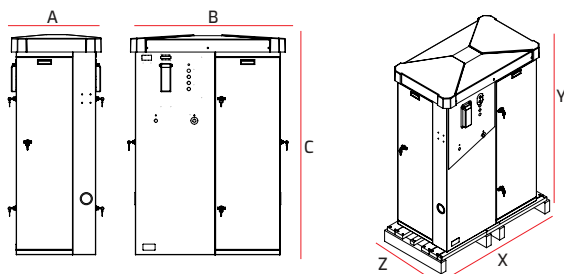

INOX
304

AC1

AC1 AIR

AC1 AIR PLUS

AC1 - AC1 AIR - AC1 AIR PLUS

ASPIRATORE SELF SINGOLO / SINGLE SELF VACUUM CLEANER

CARATTERISTICHE / FEATURES

- ▲ CHIUSURA A DUE PUNTI ANTIVANDALO
 - ▲ TEMPO CICLO PROGRAMMABILE
 - ▲ AVVIAMENTO MANUALE A RICHIESTA
 - ▲ CALOTTA IN ABS RESISTENTE AI RAGGI UV
 - ▲ TRE CONFIGURAZIONI DI USCITA DEL TUBO ASPIRATORE
 SINISTRA
 DESTRA
 RETRO
 - ▲ SPORTELLI ANTERIORI E POSTERIORI FACILMENTE RIMOVIBILI PER INTERVENTI DI MANUTENZIONE
 - ▲ NUOVI BIDONI IN ACCIAIO INOX
 - ▲ A RICHIESTA TURBINA 1,5 kW (230V-50Hz/400V - 50Hz)
 - ▲ KIT ARIA COMPRESSA INCLUSO, NECESSITA DI COLLEGAMENTO A RETE PNEUMATICA (ACT1 AIR - ACT1 AIR PLUS)
 - ▲ KIT NEBULIZZATORE INCLUSO (ACT1 AIR PLUS)

 - ▲ VANDAL-PROOF DOORS AND LOCKS
 - ▲ PROGRAMMABLE CYCLE TIME
 - ▲ MANUAL START ON DEMAND
 - ▲ ABS COVER, RESISTANT TO UV RAYS
 - ▲ THREE CONFIGURATIONS FOR VACUUM HOSE OUTLET
 LEFT
 RIGHT
 BACK
 - ▲ FRONT AND REAR COVER PANELS EASY TO REMOVE FOR MAINTENANCE OPERATIONS
 - ▲ NEW STAINLESS STEEL BINS
 - ▲ 1,5 kW TURBINE ON DEMAND (230V-50Hz/400V - 50Hz)
 - ▲ COMPRESSED AIR KIT ALWAYS SUPPLIED, REQUIRES A PNEUMATIC NETWORK CONNECTION (ACT1 AIR - ACT1 AIR PLUS)
 - ▲ SPRAY KIT INCLUDED (ACT1 AIR PLUS)

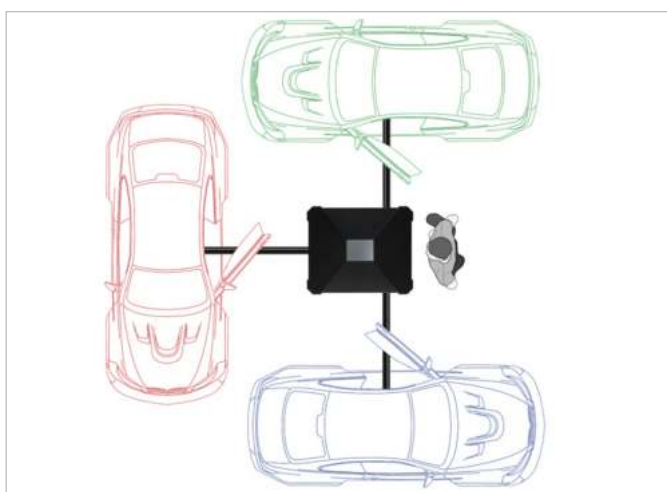

ACCESSORI IN DOTAZIONE / SUPPLIED ACCESSORIES

TUBO FLESSIBILE Ø 40 mm LUNGHEZZA 5 m
FLEXIBLE HOSE Ø 40 mm LENGHT 5 m

KIT ACCESSORI PER TUBO FLESSIBILE
FLEXIBLE HOSE ACCESSORIES KIT

COPERTURA GETTONIERA
COIN ACCEPTOR PROTECTION

BIDONE E FILTRO
A SCELTA TRA
CHOOSE THE BIN
AND THE FILTER AMONG

KIT BIDONE ASPIRATORE
55 L FILTRO POLIESTERE
VACUUM BIN 55 L
POLYESTER FILTER

FILTRO POLIESTERE COMPLETO
COMPLETE POLYESTER FILTER

KIT BIDONE ASPIRATORE
55 L FILTRO A PERDERE
VACUUM BIN 55 L
DISPOSABLE FILTER BAG

SACCO FILTRO A PERDERE 30 L
DISPOSABLE FILTER BAG 30 L

KIT BIDONE ASPIRATORE 55 L
CON PULIZIA AUTOMATICA
VACUUM BIN 55 L WITH
AUTOMATIC CLEANING

FILTRO CARTUCCIA
CARTRIDGE FILTER





ACCESSORI A RICHIESTA / ACCESSORIES ON DEMAND

BRACCIO A MOLLA VERTICALE INOX
S.STEEL VERTICAL BOOM

ETICHETTA (vedere pag. 167)
LABEL (see on pg. 167)

KIT ANTISCASSO
ARMOR KIT

DISPLAY

KIT EUROKEY NEXT
EUROKEY NEXT KIT

KIT ILLUMINAZIONE LED
LED LIGHT KIT

CASSETTO GETTONIERA LUCCHETTABILE
LOCKABLE COIN COMPARTMENT

KIT SOFFIAGGIO ARIA
AIR BLOWING KIT

ACCESSORI IN DOTAZIONE / SUPPLIED ACCESSORIES

**TUBO FLESSIBILE Ø 40 mm LUNGHEZZA 5 m
FLEXIBLE HOSE Ø 40 mm LENGHT 5 m**

**COPERTURA GETTONIERA
COIN ACCEPTOR PROTECTION**

**KIT ACCESSORI PER TUBO FLESSIBILE
FLEXIBLE HOSE ACCESSORIES KIT**

**KIT ARIA COMPRESSA
COMPRESSED AIR KIT**

**BIDONE E FILTRO
A SCELTA TRA
CHOOSE THE BIN
AND THE FILTER AMONG**

**KIT BIDONE ASPIRATORE
55 L FILTRO POLIESTERE
VACUUM BIN 55 L
POLYESTER FILTER**

**FILTRO POLIESTERE COMPLETO
COMPLETE POLYESTER FILTER**

**KIT BIDONE ASPIRATORE
55 L FILTRO A PERDERE
VACUUM BIN 55 L
DISPOSABLE FILTER BAG**

**SACCO FILTRO A PERDERE 30 L
DISPOSABLE FILTER BAG 30 L**

**KIT BIDONE ASPIRATORE 55 L
CON PULIZIA AUTOMATICA
VACUUM BIN 55 L WITH
AUTOMATIC CLEANING**

**FILTRO CARTUCCIA
CARTRIDGE FILTER**

QR CODE

ACCESSORI A RICHIESTA / ACCESSORIES ON DEMAND

**BRACCIO A MOLLA VERTICALE INOX
S.STEEL VERTICAL BOOM**

**ETICHETTA (vedere pag. 167)
LABEL (see on pg. 167)**

**KIT ANTISCASSO
ARMOR KIT**

DISPLAY

**KIT EUROKEY NEXT
EUROKEY NEXT KIT**

**KIT ILLUMINAZIONE LED
LED LIGHT KIT**

**CASSETTO GETTONIERA LUCCHETTABILE
LOCKABLE COIN COMPARTMENT**

ACCESSORI IN DOTAZIONE / SUPPLIED ACCESSORIES

TUBO FLESSIBILE Ø 40 mm LUNGHEZZA 5 m
FLEXIBLE HOSE Ø 40 mm LENGHT 5 m

KIT ACCESSORI PER TUBO FLESSIBILE
FLEXIBLE HOSE ACCESSORIES KIT

KIT ARIA COMPRESSA
COMPRESSED AIR KIT

KIT NEBULIZZATORE
SPRAY KIT

COPERTURA GETTONIERA
COIN ACCEPTOR PROTECTION

BIDONE E FILTRO
A SCELTA TRA
CHOOSE THE BIN
AND THE FILTER AMONG

KIT BIDONE ASPIRATORE
55 L FILTRO POLIESTERE
VACUUM BIN 55 L
POLYESTER FILTER

FILTRO POLIESTERE COMPLETO
COMPLETE POLYESTER FILTER

KIT BIDONE ASPIRATORE
55 L FILTRO A PERDERE
VACUUM BIN 55 L
DISPOSABLE FILTER BAG

SACCO FILTRO A PERDERE 30 L
DISPOSABLE FILTER BAG 30 L

KIT BIDONE ASPIRATORE 55 L
CON PULIZIA AUTOMATICA
VACUUM BIN 55 L WITH
AUTOMATIC CLEANING

FILTRO CARTUCCIA
CARTRIDGE FILTER

QR CODE

ACCESSORI A RICHIESTA / ACCESSORIES ON DEMAND

ETICHETTA (vedere pag. 167)
LABEL (see on pg. 167)

BRACCIO A MOLLA VERTICALE INOX
S5STEEL VERTICAL BOOM

DISPLAY

KIT ANTISCASSO
ARMOR KIT

KIT EUROKEY NEXT
EUROKEY NEXT KIT

KIT ANTIGELO
NO FROST KIT

KIT ILLUMINAZIONE LED
LED LIGHT KIT

CASSETTO GETTONIERA LUCCHETTABILE
LOCKABLE COIN COMPARTMENT

CARATTERISTICHE TECNICHE / TECHNICAL FEATURES

Codice Part No.	Modello Model	Potenza Power	Tensione Voltage	Portata d'Aria Air flow	Alimentazione Power Supply	Peso Totale Total Weight	Filtro Filter
3011420001	AC1	2,2 kW	400 V - 50 Hz	260 m ³ /h	400 V - 50 Hz 5 POLI R-S-T+N	80 kg	a perdere / disposable
3011420002	AC1	2,2 kW	400 V - 50 Hz	260 m ³ /h	400 V - 50 Hz 5 POLI R-S-T+N	80 kg	poliestere / polyester
3011520001	AC1	2,2 kW	400 V - 50 Hz	260 m ³ /h	400 V - 50 Hz 5 POLI R-S-T+N	80 kg	automatico / automatic
3011420003	AC1 AIR	2,2 kW	400 V - 50 Hz	260 m ³ /h	400 V - 50 Hz 5 POLI R-S-T+N	81 kg	a perdere / disposable
3011420004	AC1 AIR	2,2 kW	400 V - 50 Hz	260 m ³ /h	400 V - 50 Hz 5 POLI R-S-T+N	81 kg	poliestere / polyester
3011520002	AC1 AIR	2,2 kW	400 V - 50 Hz	260 m ³ /h	400 V - 50 Hz 5 POLI R-S-T+N	81 kg	automatico / automatic
3011420005	AC1 AIR PLUS	2,2 kW	400 V - 50 Hz	260 m ³ /h	400 V - 50 Hz 5 POLI R-S-T+N	82 kg	a perdere / disposable
3011420006	AC1 AIR PLUS	2,2 kW	400 V - 50 Hz	260 m ³ /h	400 V - 50 Hz 5 POLI R-S-T+N	82 kg	poliestere / polyester
3011520003	AC1 AIR PLUS	2,2 kW	400 V - 50 Hz	260 m ³ /h	400 V - 50 Hz 5 POLI R-S-T+N	82 kg	automatico / automatic

ACCESSORI IN DOTAZIONE / SUPPLIED ACCESSORIES

Codice Part No.	Modello Model	Descrizione Description
0964550011	TUTTI ALL	TUBO FLESSIBILE Ø 40 mm LUNGHEZZA 5 m FLEXIBLE HOSE Ø 40 mm LENGHT 5 m
0090611001	TUTTI ALL	KIT ACCESSORI PER TUBO FLESSIBILE FLEXIBLE HOSE ACCESSORIES KIT
0075611019*	TUTTI ALL	KIT BIDONE ASPIRATORE 55 L FILTRO POLIESTERE VACUUM BIN 55 L POLYESTER FILTER
0330211002*	TUTTI ALL	FILTRO POLIESTERE COMPLETO COMPLETE POLYESTER FILTER
0075611021*	TUTTI ALL	KIT BIDONE ASPIRATORE 55 L FILTRO A PERDERE VACUUM BIN 55 L DISPOSABLE FILTER BAG
0800020002*	TUTTI ALL	SACCO FILTRO A PERDERE 30 l DISPOSABLE FILTER BAG 30 l
0075611020*	TUTTI ALL	KIT BIDONE ASPIRATORE 55 L CON PULIZIA AUTOMATICA VACUUM BIN 55 L WITH AUTOMATIC CLEANING
0330020006*	TUTTI ALL	FILTRO CARTUCCIA CARTRIDGE FILTER
0235020005	TUTTI ALL	COPERTURA GETTONIERA COIN ACCEPTOR PROTECTION
0445611030***	AC1 AIR ACT AIR PLUS	KIT ARIA COMPRESSA COMPRESSED AIR KIT
0445611029	AC1 AIR PLUS	KIT NEBULIZZATORE SPRAY KIT

* A SECONDA DEL CODICE MACCHINA SCELTO
* DEPENDING ON THE SELECTED MACHINE CODE

*** NECESSITA DI COLLEGAMENTO A RETE PNEUMATICA
*** REQUIRES A PNEUMATIC NETWORK CONNECTION

ACCESSORI A RICHIESTA / ACCESSORIES ON DEMAND

Codice Part No.	Modello Model	Descrizione Description
0495022001	TUTTI ALL	KIT EUROKEY NEXT EUROKEY NEXT KIT
0445611047	TUTTI ALL	KIT ILLUMINAZIONE LED LED LIGHT KIT
0170242011	TUTTI ALL	CASSETTO GETTONIERA LUCCHETTABILE LOCKABLE COIN COMPARTMENT
--	TUTTI ALL	ETICHETTA (vedere pag. 179) LABEL (see on pg. 179)
0102611002	TUTTI ALL	BRACCIO A MOLLA VERTICALE INOX S.STEEL VERTICAL BOOM
0445611048	AC1 AIR PLUS	KIT ANTIGELO NO FROST KIT
0445611049	AC1	KIT SOFFIAGGIO ARIA AIR BLOWING KIT
0445611099**	TUTTI ALL	KIT ANTISCASSO ARMOR KIT
0445611050	TUTTI ALL	DISPLAY

** CODICE ESPRESSO RIFERITO A SINGOLO KIT (KIT DA INSTALLARE FRONTE E/O RETRO)
** CODE REFERRED TO A SINGLE KIT (KIT TO INSTALL FRONT AND / OR REAR)

DIMENSIONI
DIMENSIONS

A (mm)	B (mm)	C (mm)	X (mm)	Y (mm)	Z (mm)
592	714	1448	900	1578	800

IMBALLO (PALLET LEGNO + PLURIBALL)
PACKAGING (WOOD PALLET + PLURIBALL)SCHEMA DI FISSAGGIO BASAMENTO
INSTALLATION SCHEME

D (mm)	E (mm)
453	600

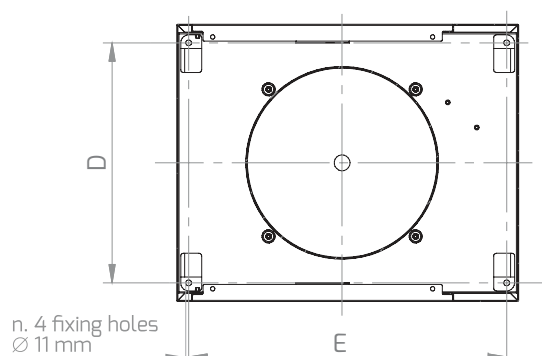
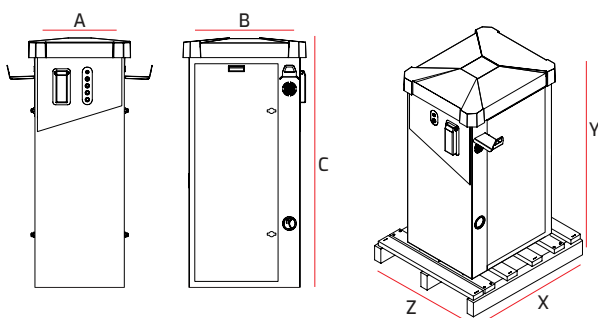

INOX
304

AC2

AC2 AIR

AC2 AIR PLUS

AC2 - AC2 AIR - AC2 AIR PLUS

ASPIRATORE SELF DOPPIO / DOUBLE SELF VACUUM CLEANER

CARATTERISTICHE / FEATURES

- ▲ PANNELLO COMANDI SUL LATO CORTO
- ▲ CHIUSURA A DUE PUNTI ANTIVANDALO
- ▲ TEMPO CICLO PROGRAMMABILE
- ▲ AVVIAMENTO MANUALE A RICHIESTA
- ▲ CALOTTA IN ABS RESISTENTE AI RAGGI UV
- ▲ DUE CONFIGURAZIONI DI USCITA DEL TUBO ASPIRATORE
 SINISTRA  DESTRA
- ▲ SPORTELLI ANTERIORI E POSTERIORI FACILMENTE RIMOVIBILI PER INTERVENTI DI MANUTENZIONE
- ▲ NUOVI BIDONI IN ACCIAIO INOX
- ▲ A RICHIESTA TURBINA 2 x 1,5 kW (230V-50Hz/400V - 50Hz)
- ▲ KIT ARIA COMPRESSA INCLUSO, NECESSITA DI COLLEGAMENTO A RETE PNEUMATICA (AC2 AIR - AC2 AIR PLUS)
- ▲ KIT NEBULIZZATORE INCLUSO (AC2 AIR PLUS)
- ▲ CONTROL PANEL ON THE SHORT SIDE
- ▲ VANDAL-PROOF DOORS AND LOCKS
- ▲ PROGRAMMABLE CYCLE TIME
- ▲ MANUAL START ON DEMAND
- ▲ ABS COVER, RESISTANT TO UV RAYS
- ▲ TWO CONFIGURATIONS FOR VACUUM HOSE OUTLET
 LEFT  RIGHT
- ▲ FRONT AND REAR COVER PANELS EASY TO REMOVE FOR MAINTENANCE OPERATIONS
- ▲ NEW STAINLESS STEEL BINS
- ▲ 2 x 1,5 kW TURBINE ON DEMAND (230V-50Hz/400V - 50Hz)
- ▲ COMPRESSED AIR KIT ALWAYS SUPPLIED, REQUIRES A PNEUMATIC NETWORK CONNECTION (AC2 AIR - AC2 AIR PLUS)
- ▲ SPRAY KIT INCLUDED (AC2 AIR PLUS)

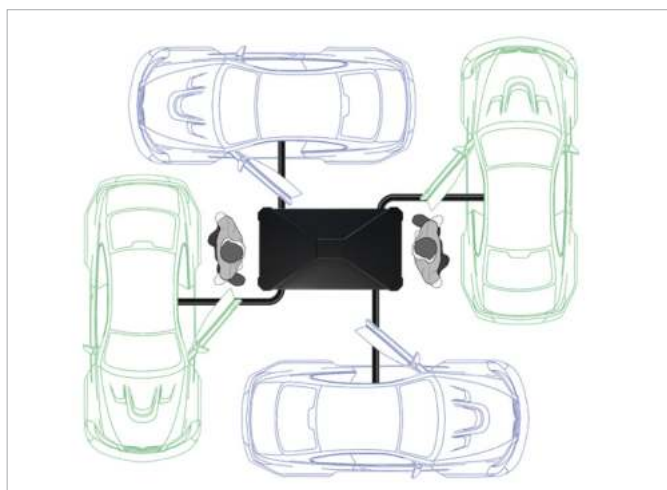

ACCESSORI IN DOTAZIONE / SUPPLIED ACCESSORIES

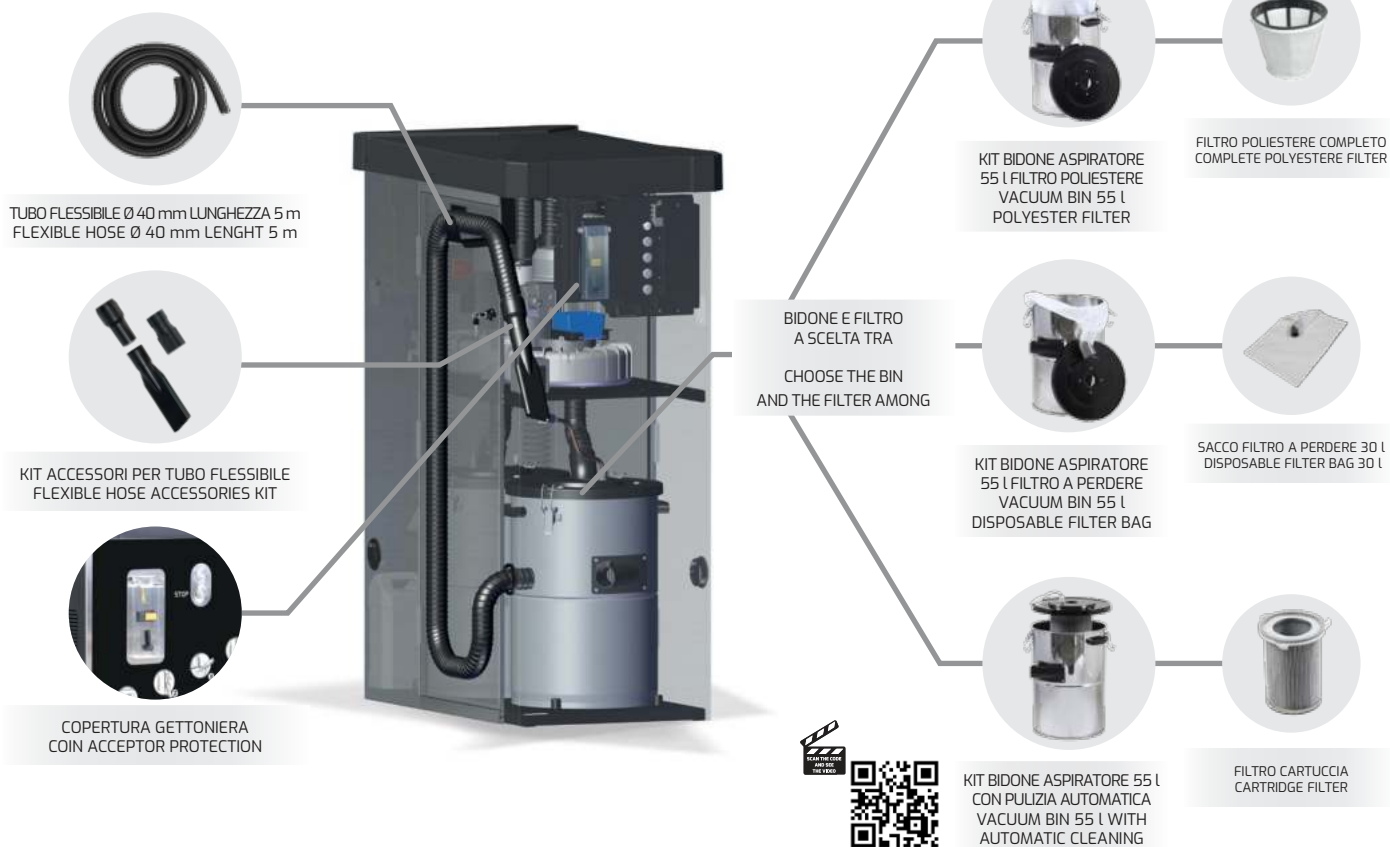

ACCESSORI A RICHIESTA / ACCESSORIES ON DEMAND



ACCESSORI IN DOTAZIONE / SUPPLIED ACCESSORIES

TUBO FLESSIBILE Ø 40 mm LUNGHEZZA 5 m
FLEXIBLE HOSE Ø 40 mm LENGHT 5 m

KIT ACCESSORI PER TUBO FLESSIBILE
FLEXIBLE HOSE ACCESSORIES KIT

KIT ARIA COMPRESSA
COMPRESSED AIR KIT

COPERTURA GETTONIERA
COIN ACCEPTOR PROTECTION

BIDONE E FILTRO
A SCELTA TRA
CHOOSE THE BIN
AND THE FILTER AMONG

KIT BIDONE ASPIRATORE
55 L FILTRO POLIESTERE
VACUUM BIN 55 L
POLYESTER FILTER

FILTRO POLIESTERE COMPLETO
COMPLETE POLYESTER FILTER

KIT BIDONE ASPIRATORE
55 L FILTRO A PERDERE
VACUUM BIN 55 L
DISPOSABLE FILTER BAG

SACCO FILTRO A PERDERE 30 L
DISPOSABLE FILTER BAG 30 L

KIT BIDONE ASPIRATORE 55 L
CON PULIZIA AUTOMATICA
VACUUM BIN 55 L WITH
AUTOMATIC CLEANING

FILTRO CARTUCCIA
CARTRIDGE FILTER

QR CODE

ACCESSORI A RICHIESTA / ACCESSORIES ON DEMAND

BRACCIO A MOLLA VERTICALE INOX
S.STEEL VERTICAL BOOM

ETICHETTA (vedere pag. 167)
LABEL (see on pg. 167)

KIT ANTISCASSO
ARMOR KIT

DISPLAY

KIT EUROKEY NEXT
EUROKEY NEXT KIT

KIT ILLUMINAZIONE LED
LED LIGHT KIT

CASSETTO GETTONIERA LUCCHETTABILE
LOCKABLE COIN COMPARTMENT

**TUBO FLESSIBILE Ø 40 mm LUNGHEZZA 5 m
FLEXIBLE HOSE Ø 40 mm LENGHT 5 m**

COPERTURA GETTONIERA COIN ACCEPTOR PROTECTION

**KIT BIDONE ASPIRATORE 55 L FILTRO POLIESTERE
VACUUM BIN 55 L POLYESTER FILTER**

**FILTRO POLIESTERE COMPLETO
COMPLETE POLYESTER FILTER**

**KIT ACCESSORI PER TUBO FLESSIBILE
FLEXIBLE HOSE ACCESSORIES KIT**

**BIDONE E FILTRO A SCELTA TRA
CHOOSE THE BIN AND THE FILTER AMONG**

**KIT BIDONE ASPIRATORE 55 L FILTRO A PERDERE
VACUUM BIN 55 L DISPOSABLE FILTER BAG**

**SACCO FILTRO A PERDERE 30 L
DISPOSABLE FILTER BAG 30 L**

KIT NEBULIZZATORE SPRAY KIT

**KIT BIDONE ASPIRATORE 55 L CON PULIZIA AUTOMATICA
VACUUM BIN 55 L WITH AUTOMATIC CLEANING**

**FILTRO CARTUCCIA
CARTRIDGE FILTER**

**KIT ARIA COMPRESSA
COMPRESSED AIR KIT**

QR CODE

ACCESSORI A RICHIESTA / ACCESSORIES ON DEMAND

**BRACCIO A MOLLA VERTICALE INOX
S.STEEL VERTICAL BOOM**

DISPLAY

**ETICHETTA (vedere pag. 167)
LABEL (see on pg. 167)**

**KIT EUROKEY NEXT
EUROKEY NEXT KIT**

**KIT ANTISCASSO
ARMOR KIT**

**KIT ILLUMINAZIONE LED
LED LIGHT KIT**

**CASSETTO GETTONIERA LUCCHETTABILE
LOCKABLE COIN COMPARTMENT**

**KIT ANTIGELO
NO FROST KIT**

CARATTERISTICHE TECNICHE / TECHNICAL FEATURES

Codice Part No.	Modello Model	Potenza Power	Tensione Voltage	Portata d'Aria Air flow	Alimentazione Power Supply	Peso Totale Total Weight	Filtro Filter
3011720001	AC2	2 x 2,2 kW	400 V - 50 Hz	260 m ³ /h	400 V - 50 Hz 5 POLI R-S-T+N	130 kg	a perdere / disposable
3011720002	AC2	2 x 2,2 kW	400 V - 50 Hz	260 m ³ /h	400 V - 50 Hz 5 POLI R-S-T+N	130 kg	poliestere / polyester
3011820001	AC2	2 x 2,2 kW	400 V - 50 Hz	260 m ³ /h	400 V - 50 Hz 5 POLI R-S-T+N	130 kg	automatico / automatic
3011720003	AC2 AIR	2 x 2,2 kW	400 V - 50 Hz	260 m ³ /h	400 V - 50 Hz 5 POLI R-S-T+N	132 kg	a perdere / disposable
3011720004	AC2 AIR	2 x 2,2 kW	400 V - 50 Hz	260 m ³ /h	400 V - 50 Hz 5 POLI R-S-T+N	132 kg	poliestere / polyester
3011820002	AC2 AIR	2 x 2,2 kW	400 V - 50 Hz	260 m ³ /h	400 V - 50 Hz 5 POLI R-S-T+N	132 kg	automatico / automatic
3011720005	AC2 AIR PLUS	2 x 2,2 kW	400 V - 50 Hz	260 m ³ /h	400 V - 50 Hz 5 POLI R-S-T+N	134 kg	a perdere / disposable
3011720006	AC2 AIR PLUS	2 x 2,2 kW	400 V - 50 Hz	260 m ³ /h	400 V - 50 Hz 5 POLI R-S-T+N	134 kg	poliestere / polyester
3011820003	AC2 AIR PLUS	2 x 2,2 kW	400 V - 50 Hz	260 m ³ /h	400 V - 50 Hz 5 POLI R-S-T+N	134 kg	automatico / automatic

ACCESSORI IN DOTAZIONE / SUPPLIED ACCESSORIES

ACCESSORI A RICHIESTA / ACCESSORIES ON DEMAND

Codice Part No.	Modello Model	Descrizione Description	Codice Part No.	Modello Model	Descrizione Description
0964550011	TUTTI ALL	TUBO FLESSIBILE Ø 40 mm LUNGHEZZA 5 m FLEXIBLE HOSE Ø 40 mm LENGTH 5 m	0495022001	TUTTI ALL	KIT EUROKEY NEXT EUROKEY NEXT KIT
0090611001	TUTTI ALL	KIT ACCESSORI PER TUBO FLESSIBILE FLEXIBLE HOSE ACCESSORIES KIT	0445611047	TUTTI ALL	KIT ILLUMINAZIONE LED LED LIGHT KIT
0075611019*	TUTTI ALL	KIT BIDONE ASPIRATORE 55 l FILTRO POLIESTERE VACUUM BIN 55 l POLYESTER FILTER	0170242011	TUTTI ALL	CASSETTO GETTONIERA LUCCHETTABILE LOCKABLE COIN COMPARTMENT
0330211002*	TUTTI ALL	FILTRO POLIESTERE COMPLETO COMPLETE POLYESTER FILTER	--	TUTTI ALL	ETICHETTA (vedere pag. 179) LABEL (see on pg. 179)
0075611021*	TUTTI ALL	KIT BIDONE ASPIRATORE 55 l FILTRO A PERDERE VACUUM BIN 55 l DISPOSABLE FILTER BAG	0102611002	TUTTI ALL	BRACCIO A MOLLA VERTICALE INOX S.STEEL VERTICAL BOOM
0800020002*	TUTTI ALL	SACCO FILTRO A PERDERE 30 l DISPOSABLE FILTER BAG 30 l	0445611048	AC2 AIR PLUS	KIT ANTIGELO NO FROST KIT
0075611020*	TUTTI ALL	KIT BIDONE ASPIRATORE 55 l CON PULIZIA AUTOMATICA VACUUM BIN 55 l WITH AUTOMATIC CLEANING	0445611049	AC2	KIT SOFFIAGGIO ARIA AIR BLOWING KIT
0330020006	TUTTI ALL	FILTRO CARTUCCIA CARTRIDGE FILTER	0445611099**	TUTTI ALL	KIT ANTISCASSO ARMOR KIT
0235020005	TUTTI ALL	COPERTURA GETTONIERA COIN ACCEPTOR PROTECTION	0445611050	TUTTI ALL	DISPLAY
0445611030***	AC2 AIR AC2AIRPLUS	KIT ARIA COMPRESSA COMPRESSED AIR KIT	** CODICE ESPRESSO RIFERITO A SINGOLO KIT (KIT DA INSTALLARE FRONTE E/O RETRO) ** CODE REFERRED TO A SINGLE KIT (KIT TO INSTALL FRONT AND / OR REAR)		
0445611029	AC2AIRPLUS	KIT NEBULIZZATORE SPRAY KIT			

* A SECONDA DEL CODICE MACCHINA SCELTO
* DEPENDING ON THE SELECTED MACHINE CODE

*** NECESSITA DI COLLEGAMENTO A RETE PNEUMATICA
*** REQUIRES A PNEUMATIC NETWORK CONNECTION

DIMENSIONI
DIMENSIONSIMBALLO (PALLET LEGNO + PLURIBALL)
PACKAGING (WOOD PALLET + PLURIBALL)SCHEMA DI FISSAGGIO BASAMENTO
INSTALLATION SCHEME

A (mm)	B (mm)	C (mm)	X (mm)	Y (mm)	Z (mm)	D (mm)	E (mm)
592	1019	1448	1150	1578	600	905	453

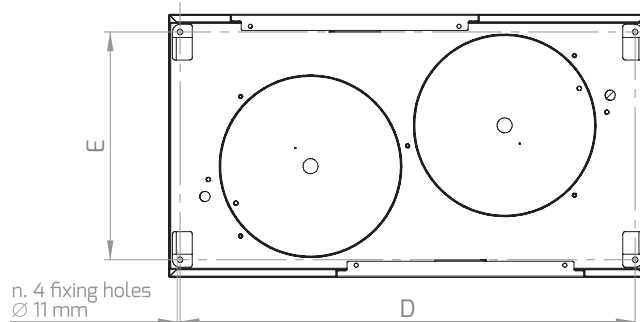
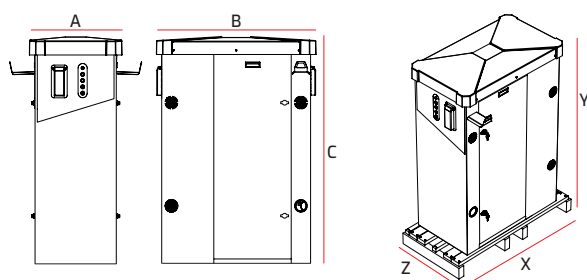





AL1

ASPIRATORE SELF SINGOLO / SINGLE SELF VACUUM CLEANER

CARATTERISTICHE / FEATURES

- ▲ CHIUSURA A DUE PUNTI ANTIVANDALO
- ▲ TEMPO CICLO PROGRAMMABILE
- ▲ AVVIAMENTO MANUALE A RICHIESTA
- ▲ CALOTTA IN ABS RESISTENTE AI RAGGI UV
- ▲ QUADRO ELETTRICO E GETTONIERA ELETTRONICA INTEGRATI
- ▲ TRE CONFIGURAZIONI DI USCITA DEL TUBO ASPIRATORE

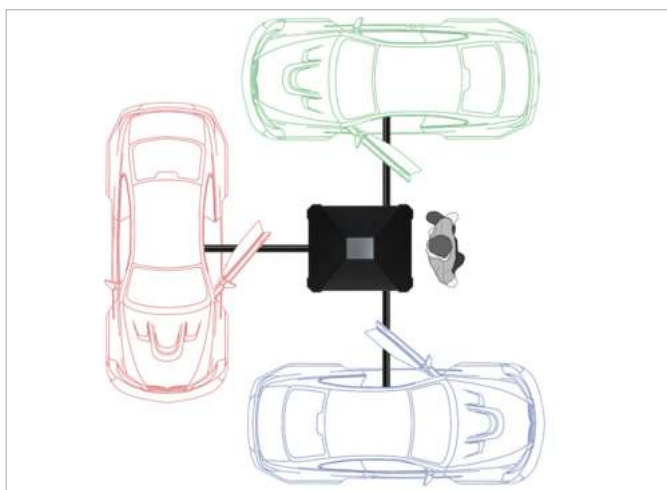
- ▲ SPORTELLI ANTERIORI E POSTERIORI FACILMENTE RIMOVIBILI PER INTERVENTI DI MANUTENZIONE
- ▲ NUOVI BIDONI IN ACCIAIO INOX
- ▲ VANDAL-PROOF DOORS AND LOCKS
- ▲ PROGRAMMABLE CYCLE TIME
- ▲ MANUAL START ON DEMAND
- ▲ ABS COVER, RESISTANT TO UV RAYS
- ▲ INTEGRATED ELECTRONIC CONTROL BOARD
- ▲ THREE CONFIGURATIONS FOR VACUUM HOSE OUTLET

- ▲ FRONT AND REAR COVER PANELS EASY TO REMOVE FOR MAINTENANCE OPERATIONS
- ▲ NEW STAINLESS STEEL BINS



ACCESSORI IN DOTAZIONE / SUPPLIED ACCESSORIES

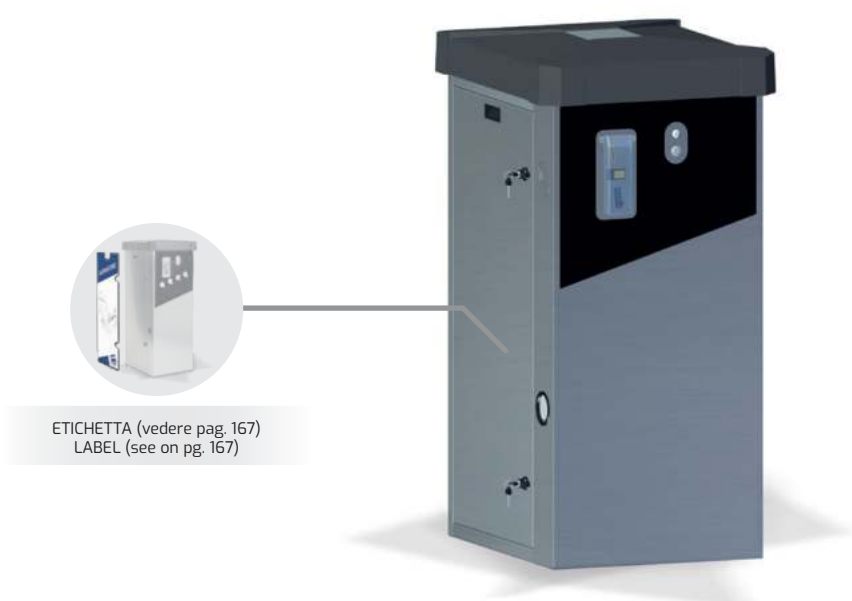

ACCESSORI A RICHIESTA / ACCESSORIES ON DEMAND



CARATTERISTICHE TECNICHE / TECHNICAL FEATURES

Codice Part No.	Potenza Power	Tensione Voltage	Portata d'Aria Air flow	Alimentazione Power Supply	Peso Totale Total Weight	Filtro Filter
3011350002	1,2 kW	230 V - 50 Hz	220 m ³ /h	230 V - 50 Hz	50 kg	a perdere / disposable
3011350001	1,2 kW	230 V - 50 Hz	220 m ³ /h	230 V - 50 Hz	50 kg	poliestere / polyester

ACCESSORI IN DOTAZIONE / SUPPLIED ACCESSORIES

Codice Part No.	Descrizione Description
0964550011	TUBO FLESSIBILE Ø 40 mm LUNGHEZZA 5 m FLEXIBLE HOSE Ø 40 mm LENGHT 5 m
0090611001	KIT ACCESSORI PER TUBO FLESSIBILE FLEXIBLE HOSE ACCESSORIES KIT
0942611001*	TESTATA ASPIRATORE CON BIDONE FILTRO POLIESTERE VACUUM HEAD WITH POLYESTER FILTER BIN
0330211002*	FILTRO POLIESTERE COMPLETO COMPLETE POLYESTER FILTER
0942611003*	TESTATA ASPIRATORE CON BIDONE FILTRO A PERDERE VACUUM HEAD WITH DISPOSABLE FILTER BIN
0800020002*	SACCO FILTRO A PERDERE 30 l DISPOSABLE FILTER BAG 30 l
0235020005	COPERTURA GETTONIERA COIN ACCEPTOR PROTECTION

* A SECONDA DEL CODICE MACCHINA SCELTO
* DEPENDING ON THE SELECTED MACHINE CODE

ACCESSORI A RICHIESTA / ACCESSORIES ON DEMAND

Codice Part No.	Descrizione Description
--	ETICHETTA (vedere pag. 179) LABEL (see on pg. 179)

DIMENSIONI
DIMENSIONSIMBALLO (PALLET LEGNO + PLURIBALL)
PACKAGING (WOOD PALLET + PLURIBALL)SCHEMA DI FISSAGGIO BASAMENTO
INSTALLATION SCHEME

A (mm)	B (mm)	C (mm)	X (mm)	Y (mm)	Z (mm)	D (mm)	E (mm)
592	714	1198	900	1328	800	453	600

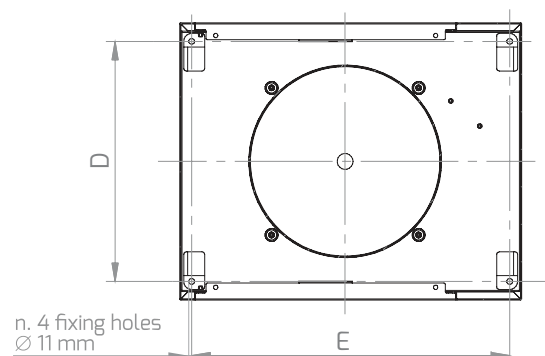
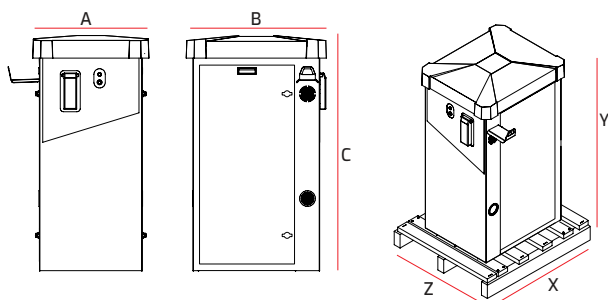



AL2

ASPIRATORE SELF DOPPIO / DOUBLE SELF VACUUM CLEANER

CARATTERISTICHE / FEATURES

- ▼ CHIUSURA A DUE PUNTI ANTIVANDALO
 - ▼ TEMPO CICLO PROGRAMMABILE
 - ▼ AVVIAMENTO MANUALE A RICHIESTA
 - ▼ CALOTTA IN ABS RESISTENTE AI RAGGI UV
 - ▼ QUADRO ELETTRICO E GETTONIERA ELETTRONICA INTEGRATI
 - ▼ DUE CONFIGURAZIONI DI USCITA DEL TUBO ASPIRATORE
 - ▼ SPORTELLI ANTERIORI E POSTERIORI FACILMENTE RIMOVIBILI PER INTERVENTI DI MANUTENZIONE
 - ▼ NUOVI BIDONI IN ACCIAIO INOX
- ▼ VANDAL-PROOF DOORS AND LOCKS
 - ▼ PROGRAMMABLE CYCLE TIME
 - ▼ MANUAL START ON DEMAND
 - ▼ ABS COVER, RESISTANT TO UV RAYS
 - ▼ INTEGRATED ELECTRONIC CONTROL BOARD
 - ▼ TWO CONFIGURATIONS FOR VACUUM HOSE OUTLET
 - ▼ FRONT AND REAR COVER PANELS EASY TO REMOVE FOR MAINTENANCE OPERATIONS
 - ▼ NEW STAINLESS STEEL BINS

 SINISTRA  DESTRA

 LEFT  RIGHT

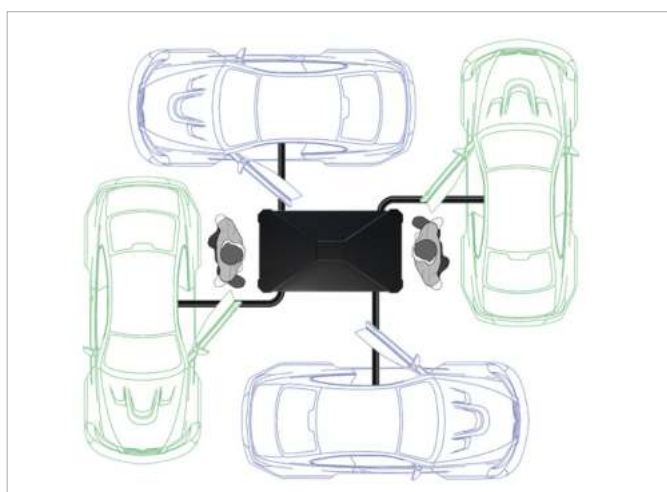

ACCESSORI IN DOTAZIONE / SUPPLIED ACCESSORIES

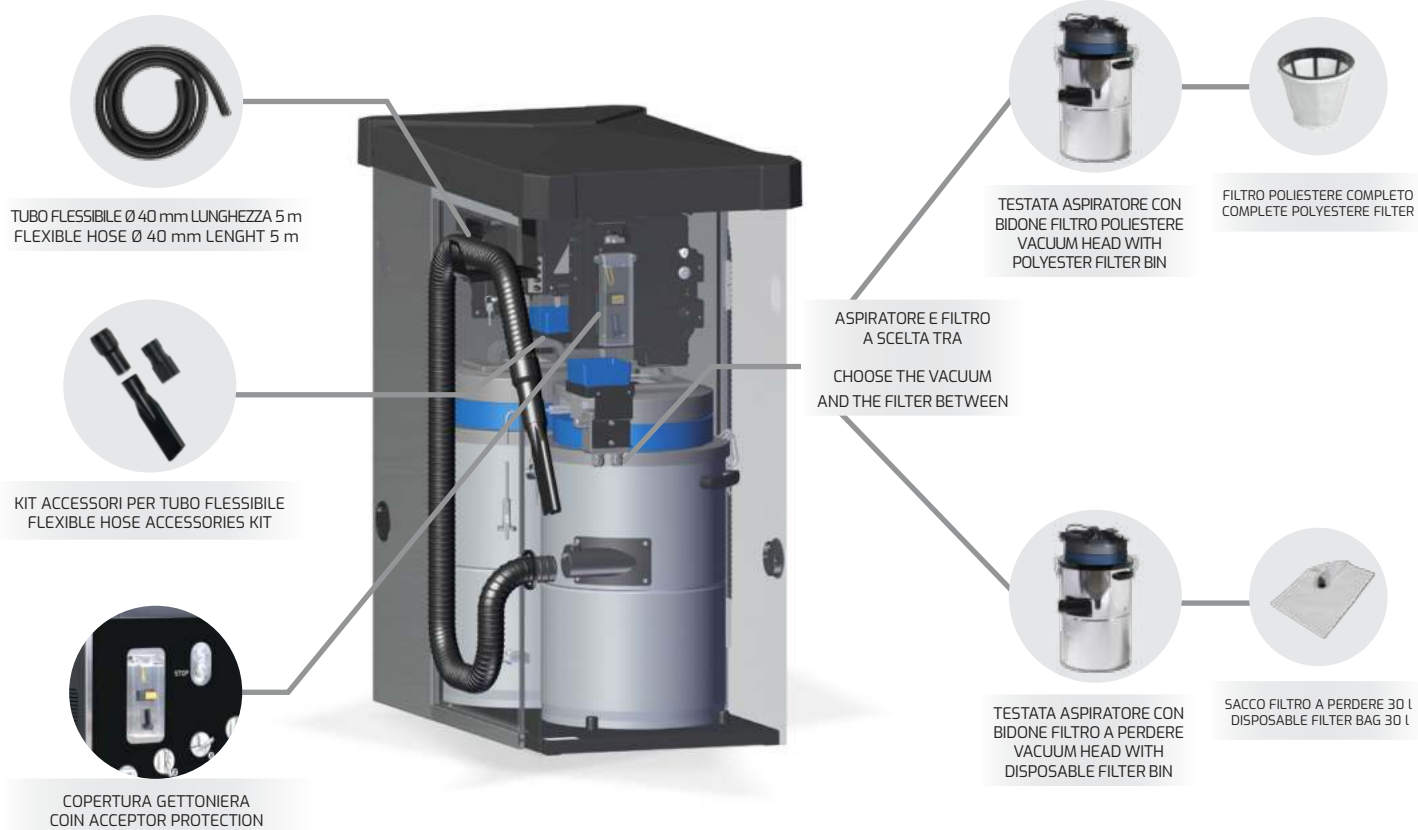

ACCESSORI A RICHIESTA / ACCESSORIES ON DEMAND



CARATTERISTICHE TECNICHE / TECHNICAL FEATURES

Codice Part No.	Potenza Power	Tensione Voltage	Portata d'Aria Air flow	Alimentazione Power Supply	Peso Totale Total Weight	Filtro Filter
3011650002	2 x 1,2 kW	230 V - 50 Hz	220 m ³ /h	230 V - 50 Hz	80 kg	a perdere / disposable
3011650001	2 x 1,2 kW	230 V - 50 Hz	220 m ³ /h	230 V - 50 Hz	80 kg	poliestere / polyester

ACCESSORI IN DOTAZIONE / SUPPLIED ACCESSORIES

Codice (1 pz.) Part No. (1 piece)	Descrizione Description	Quantità Quantity
0964550011	TUBO FLESSIBILE Ø 40 mm LUNGHEZZA 5 m FLEXIBLE HOSE Ø 40 mm LENGHT 5 m	2
0090611001	KIT ACCESSORI PER TUBO FLESSIBILE FLEXIBLE HOSE ACCESSORIES KIT	2
0942611001*	TESTATA ASPIRATORE CON BIDONE FILTRO POLIESTERE VACUUM HEAD WITH POLYESTER FILTER BIN	2
0330211002*	FILTRO POLIESTERE COMPLETO COMPLETE POLYESTER FILTER	2
0942611003*	TESTATA ASPIRATORE CON BIDONE FILTRO A PERDERE VACUUM HEAD WITH DISPOSABLE FILTER BIN	2
0800020002*	SACCO FILTRO A PERDERE 30 l DISPOSABLE FILTER BAG 30 l	2
0235020005	COPERTURA GETTONIERA COIN ACCEPTOR PROTECTION	2

* A SECONDA DEL CODICE MACCHINA SCELTO

* DEPENDING ON THE SELECTED MACHINE CODE

ACCESSORI A RICHIESTA / ACCESSORIES ON DEMAND

Codice (1 pz.) Part No. (1 piece)	Descrizione Description
--	ETICHETTA (vedere pag. 179) LABEL (see on pg. 179)

DIMENSIONI
DIMENSIONSIMBALLO (PALLET LEGNO + PLURIBALL)
PACKAGING (WOOD PALLET + PLURIBALL)SCHEMA DI FISSAGGIO BASAMENTO
INSTALLATION SCHEME

A (mm)	B (mm)	C (mm)	X (mm)	Y (mm)	Z (mm)	D (mm)	E (mm)
592	1019	1198	1150	1328	600	905	453

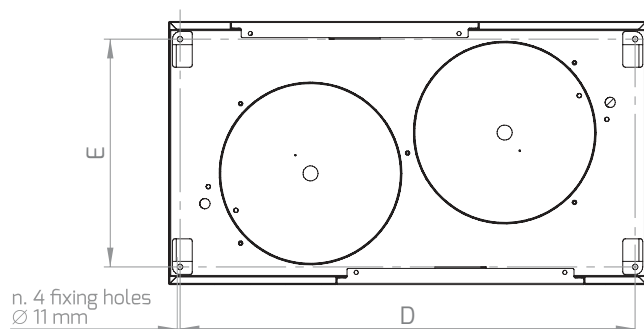
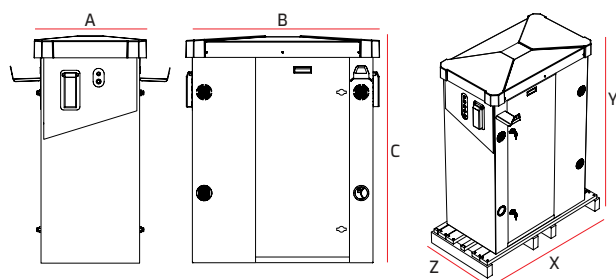





INOX
304



MC

LAVATAPPETI / MAT CLEANER

CARATTERISTICHE / FEATURES

- ▼ PULIZIA TAPPETINI FINO A 80 cm DI LARGHEZZA
- ▼ CAR MAT CLEANING UP TO 80 cm IN WIDTH
- ▼ UTILIZZABILE PER TAPPETINI IN TESSUTO O GOMMA
- ▼ SUITABLE FOR CLOTH OR RUBBER CAR MATS
- ▼ TEMPO CICLO PROGRAMMABILE
- ▼ PROGRAMMABLE CYCLE TIME
- ▼ AVVIAMENTO MANUALE A RICHIESTA
- ▼ MANUAL START ON DEMAND
- ▼ CALOTTA IN ABS RESISTENTE AI RAGGI UV
- ▼ ABS COVER, RESISTANT TO UV RAYS
- ▼ RIMOZIONE DEL GRUPPO SPAZZOLA FACILITATA
- ▼ EASY REMOVAL OF BRUSH UNIT
- ▼ SPORTELLI LATERALI INCERNIERATI PER UNA FACILE MANUTENZIONE
- ▼ HINGED SIDE PANELS FOR EASY MAINTENANCE
- ▼ QUADRO ELETTRICO E GETTONIERA ELETTRONICA INTEGRATI E DI FACILE ACCESSO
- ▼ EASY ACCESS INTEGRATED ELECTRONIC CONTROL BOARD
- ▼ PREDISPOSIZIONE PER PULSANTIERA PERSONALIZZATA A SECONDA DEGLI ACCESSORI INSTALLATI
- ▼ PREDISPOSED FOR PERSONALIZED BUTTON PAD BASED ON INSTALLED ACCESSORIES



ACCESSORI IN DOTAZIONE E A RICHIESTA / SUPPLIED AND ON DEMAND ACCESSORIES



KIT MENSOLA
SHELF KIT



KIT EUROKEY NEXT
EUROKEY NEXT KIT



KIT PORTATAPPETI
MAT HOLDER SHELF KIT



DISPLAY



COPERTURA GETTONIERA
COIN ACCEPTOR PROTECTION
(accessorio in dotazione/
supplied accessory)



CASSETTO GETTONIERALUCCHETTABILE
LOCKABLE COIN COMPARTMENT



ETICHETTA (vedere pag. 167)
LABEL (see on pg. 167)



KIT NEBULIZZATORE
SPRAY KIT



KIT ANTIBATTERICO**
ANTIBACTERIAL KIT**



KIT VAPORE
STEAM KIT



KIT ACQUA
WATER KIT



KIT ANTIGELO**
NO FROST KIT**



KIT ARIA COMPRESSA
COMPRESSED AIR KIT

** KIT ANTIGELO E KIT ANTIBATTERICO DISPONIBILI SOLO IN ABBINAMENTO AL KIT ACQUA
** NO FROST KIT AND ANTIBACTERIAL KIT AVAILABLE ONLY IN COMBINATION WITH THE WATER KIT

CARATTERISTICHE TECNICHE / TECHNICAL FEATURES

Codice Part No.	Kit Acqua Water Kit	Kit Antigelo ** No Frost Kit **	Kit Vapore Steam Kit	Kit Antibatterico** Antibacterial Kit**	Tensione Voltage	Potenza Power	Peso Totale Total Weight
3020310020					230 V - 50 Hz	250W	80 kg
3020310021	✓				230 V - 50 Hz	250W	80 kg
3020310022	✓	✓			230 V - 50 Hz	250W	80 kg
3020320030					400 V - 50 Hz	250W	80 kg
3020320031	✓				400 V - 50 Hz	250W	80 kg
3020320032	✓	✓			400 V - 50 Hz	250W	80 kg
3020220005			✓		400 V - 50 Hz	4kW	90 kg
3020* * * * * *	✱	✱	✱	✱	--	--	--

✱ Altre combinazioni (ACQUA, ARIA, SPRAY, ANTIGELO, ANTIBATTERICO, ecc...) disponibili su richiesta

✱ Other configurations (WATER, AIR, SPRAY, NO FROST, ANTIBACTERIAL, ecc...) available on demand

**KIT ANTIGELO E KIT ANTIBATTERICO DISPONIBILI SOLO IN ABBINAMENTO AL KIT ACQUA

** NO FROST KIT AND ANTIBACTERIAL KIT AVAILABLE ONLY IN COMBINATION WITH THE WATER KIT

ACCESSORI IN DOTAZIONE / SUPPLIED ACCESSORIES

ACCESSORI A RICHIESTA / ACCESSORIES ON DEMAND

Codice Part No.	Descrizione Description	Codice Part No.	Descrizione Description
0445611051*	KIT ACQUA WATER KIT	0170242014	CASSETTO GETTONI LUCCHETTABILE LOCKABLE COIN COMPARTMENT
0445611052*	KIT ANTIGELO NO FROST KIT	0765611005	KIT ACCESSORIO MENSOLA SHELF KIT
0445611053*	KIT ANTIBATTERICO ANTIBACTERIAL KIT	0900611002	KIT PORTATAPPETI MAT HOLDER SHELF KIT
0445611054*	KIT VAPORE STEAM KIT	0445611055	KIT NEBULIZZATORE SPRAY KIT
0235020005	COPERTURA GETTONIERA COIN ACCEPTOR PROTECTION	0445611056**	KIT ARIA COMPRESSA COMPRESSED AIR KIT
		0495022001	KIT EUROKEY NEXT EUROKEY NEXT KIT
		0445611050	DISPLAY

* A SECONDA DEL CODICE MACCHINA SCELTO
* DEPENDING ON THE SELECTED MACHINE CODE

--
ETICHETTA (vedere pag. 179)
LABEL (see on pg. 179)

** NECESSITA DI COLLEGAMENTO A RETE PNEUMATICA
** REQUIRES A PNEUMATIC NETWORK CONNECTION

DIMENSIONI
DIMENSIONSIMBALLO (PALLET LEGNO + PLURIBALL)
PACKAGING (WOOD PALLET + PLURIBALL)SCHEMA DI FISSAGGIO BASAMENTO
INSTALLATION SCHEME

A (mm)	B (mm)	C (mm)	X (mm)	Y (mm)	Z (mm)	D (mm)	E (mm)	F (mm)	G (mm)
531	1093	1099	1150	1229	600	780	1085	520	380

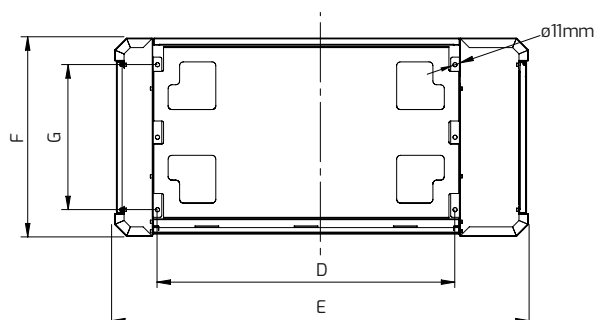
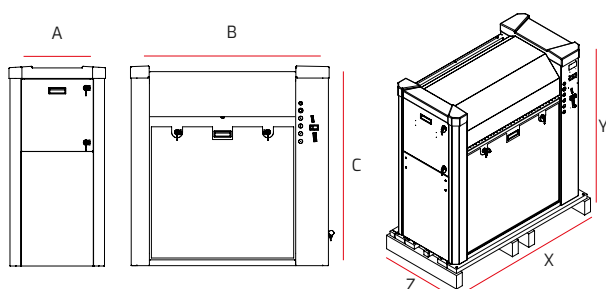

LAVATAPPETI SELF

STOP



MTM
HYDRO
CAR WASH EQUIPMENT

The image shows a self-service handwashing station. At the top, there is a row of six circular icons: 1. A hand with a red eye and a red 'X' over it, indicating eye safety. 2. A hand being washed under a stream of water. 3. A hand being washed with soap bubbles. 4. A hand being washed with water. 5. A hand being washed with water. 6. A hand being washed with water. Below the icons is the text 'LAVATAPPETI SELF'. To the right of this text is a red 'STOP' button and a blue button with a water drop icon. Below the text is a dark grey panel with two small diamond-shaped holes. Below that is a white panel with a line drawing of a hand being washed in a basin. At the bottom right of the white panel is the logo 'MTM HYDRO CAR WASH EQUIPMENT'. To the right of the main unit is a separate grey metal grate structure.





03 LAVAINTERNI CAR SEAT WASH

01 AC DRY LAVAINTERNI SELF A SCHIUMA SECCA · DRY FOAM CAR SEAT WASH 065

02 AC WET LAVAINTERNI SELF INIEZIONE · ESTRAZIONE · INJECTION · EXTRACTION FOAM CAR SEAT WASH 069

03 AL WET LAVAINTERNI SELF INIEZIONE · ESTRAZIONE · INJECTION · EXTRACTION FOAM CAR SEAT WASH 073



L'**ACCIAIO INOX** che utilizziamo per le nostre macchine è del tipo AISI 304 quindi a basso contenuto di carbonio.
I principali vantaggi di questo materiale per le nostre applicazioni sono :

- Elevata resistenza alle intemperie e corrosione
- Facilità di ripulitura e ottimo coefficiente igienico.

*The **STAINLESS STEEL** used in the construction of our machines is of the type AISI 304 with low carbon content.*

The main advantages of this material for our applications are:

- High level of resistance to extreme weather and corrosion
- Ease of cleaning and maintenance and excellent hygiene properties.

AC DRY

AC WET

AL WET

✓

✓

✓



In questo caso la **SCHIUMA** viene definita **SECCA** in quanto prodotta da un sistema ad aria compressa e quindi non miscelata con acqua , il vantaggio è quindi che il tessuto richiede molto meno tempo per asciugare.

*In this case, the **FOAM** is defined as **DRY** because it is generated by a system working with compressed air and not mixed with water. The advantage is that the tissue requires much less time to dry.*

✓



Il sistema di **INIEZIONE-ESTRAZIONE DI SCHIUMA**, miscelata con acqua, offre una notevole azione detergente anche in profondità nel tessuto e facile rimozione dello sporco.

*In this case the **FOAM** is called **DRY** as it is produced by a compressed air system and is not mixed with water, with the advantage of requiring less drying time.*

✓

✓



SCHEDA ELETTRONICA, dotata di temporizzatore elettronico, svolge una o più azioni a intervalli di tempo prefissati, facilmente regolabile secondo le esigenze del cliente.

*The **ELECTRONIC CIRCUIT BOARD**, supplied with an electronic timer, manages one or more functions at prefixed intervals, and is easily adjustable according to the client's needs.*

✓

✓

✓



La **GETTONIERA ELETTRONICA**, offerta di serie, combina una straordinaria selettività ad un'estrema versatilità di programmazione.

*The **ELECTRONIC TOKEN AND COIN-OP** mechanism, supplied as standard equipment, combines extraordinary versatility with extreme programming flexibility.*

✓

✓

✓



AC DRY

LAVAINTERNI SELF A SCHIUMA SECCA / DRY FOAM CAR SEAT WASH

CARATTERISTICHE / FEATURES

- ❖ CHIUSURA A DUE PUNTI ANTIVANDALO
 - ❖ POMPA CON BY-PASS 4 BAR 1.5 l/min
 - ❖ MOTORE ASPIRAZIONE BISTADIO 1500 W
 - ❖ COMPRESSORE 8 BAR CON SEBATOIO DA 6 L
 - ❖ SERBATOIO PRODOTTO CHIMICO 14 L - SERBATOIO RACCOLTA SPORCO 14 L
 - ❖ AVVIAMENTO MANUALE A RICHIESTA
 - ❖ COPERTURA IN ABS RESISTENTE AI RAGGI UV
 - ❖ QUADRO ELETTRICO E GETTONIERA ELETTRONICA INTEGRATI
 - ❖ DUE CONFIGURAZIONI DI USCITA DEL TUBO ASPIRATORE
← SINISTRA → DESTRA
 - ❖ SPORTELLI ANTERIORI E POSTERIORI FACILMENTE RIMOVIBILI PER INTERVENTI DI MANUTENZIONE
 - ❖ PRODOTTO CHIMICO NON FORNITO

 - ❖ VANDAL-PROOF DOORS AND LOCKS
 - ❖ PUMP WITH BY-PASS 4 BAR 1.5 l/min
 - ❖ TWO-STAGE VACUUM MOTOR 1500W
 - ❖ 8 BAR COMPRESSOR WITH 6 LTANK
 - ❖ 14 L CHEMICAL PRODUCT TANK- 14 L DIRT COLLECTING TANK
 - ❖ MANUAL START ON DEMAND
 - ❖ ABS COVER, RESISTANT TO UV RAYS
 - ❖ INTEGRATED ELECTRONIC CONTROL BOARD
 - ❖ TWO CONFIGURATIONS FOR VACUUM HOSE OUTLET
← LEFT → RIGHT
 - ❖ FRONT AND REAR COVER PANELS EASY TO REMOVE FOR MAINTENANCE OPERATIONS
 - ❖ CHEMICAL PRODUCT NOT INCLUDED

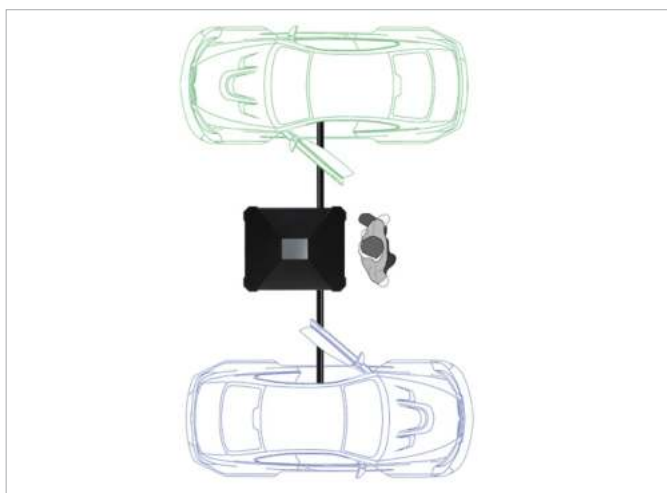

ACCESSORI IN DOTAZIONE / SUPPLIED ACCESSORIES



ACCESSORI A RICHIESTA / ACCESSORIES ON DEMAND

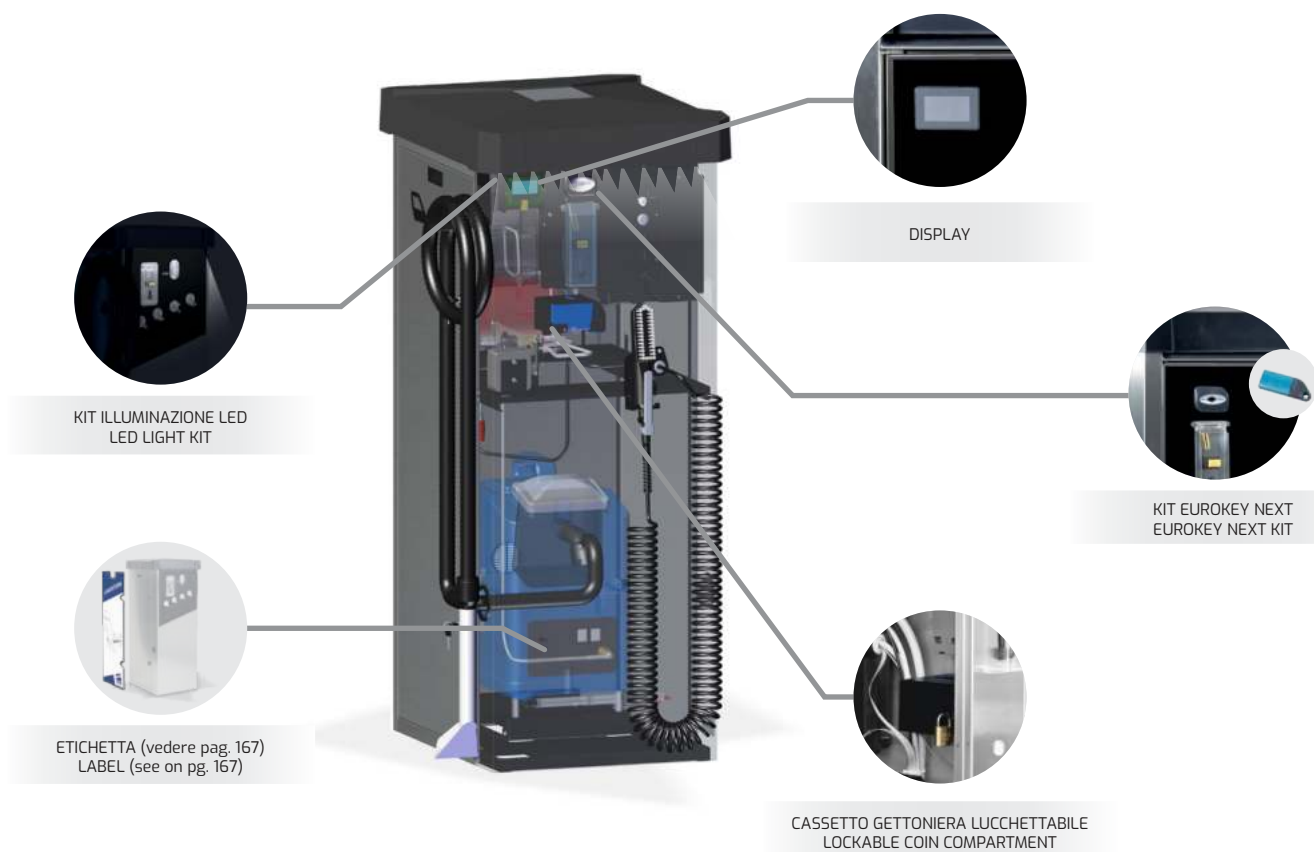

CARATTERISTICHE TECNICHE / TECHNICAL FEATURES

Codice Part No.	Compressore Compressor	Potenza Power	Tensione Voltage	Portata d'Aria Air flow	Peso Totale Total Weight
3030310001		1,5 kW	230 V - 50 Hz	220 m ³ /h	80 kg
3030310002	✓	2 kW	230 V - 50 Hz	220 m ³ /h	85 kg

ACCESSORI IN DOTAZIONE / SUPPLIED ACCESSORIES

Codice Part No.	Descrizione Description
0964611006	TUBO FLESSIBILE LAVAINTERNI Ø 32 mm LUNGHEZZA 5 m CAR SEAT WASH FLEXIBLE HOSE Ø 32 mm LENGTH 5 m
0090027003	BOCCHETTA A MANO LAVAINTERNI CAR SEAT UPHOLSTERY HAND TOOL
0860020002	SPAZZOLA COMPLETA LAVAINTERNI COMPLETE CAR SEAT WASH BRUSH
0235020005	COPERTURA GETTONIERA COIN ACCEPTOR PROTECTION

ACCESSORI A RICHIESTA / ACCESSORIES ON DEMAND

Codice Part No.	Descrizione Description
0495022001	KIT EUROKEY NEXT EUROKEY NEXT KIT
0445611047	KIT ILLUMINAZIONE LED LED LIGHT KIT
0170242011	CASSETTO GETTONIERA LUCCHETTABILE LOCKABLE COIN COMPARTMENT
0445611050	DISPLAY
--	ETICHETTA (vedere pag. 179) LABEL (see on pg. 179)

PRINCIPIO DI FUNZIONAMENTO / WORKING SYSTEM

DIMENSIONI
DIMENSIONSIMBALLO (PALLET LEGNO + PLURIBALL)
PACKAGING (WOOD PALLET + PLURIBALL)SCHEMA DI FISSAGGIO BASAMENTO
INSTALLATION SCHEME

A (mm)	B (mm)	C (mm)	X (mm)	Y (mm)	Z (mm)	D (mm)	E (mm)
592	714	1448	900	1578	800	453	600

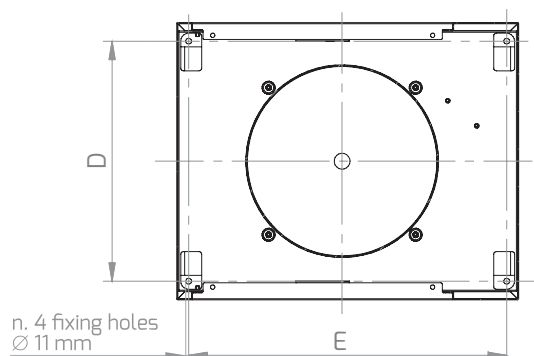
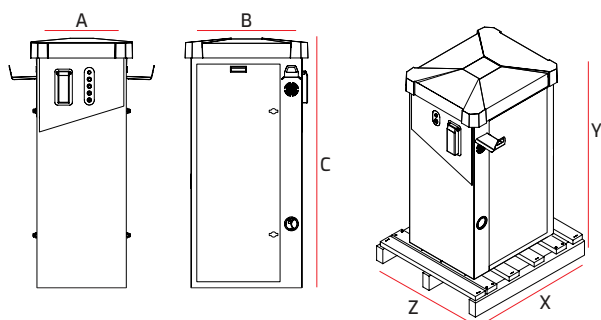







AC WET

LAVAINTERNI SELF INIEZIONE · ESTRAZIONE / INJECTION · EXTRACTION CAR SEAT WASH

CARATTERISTICHE / FEATURES

- ▼ CHIUSURA A DUE PUNTI ANTIVANDALO
- ▼ BIDONE CON SCARICO AUTOMATICO
- ▼ PRESSOSTATO GESTIONE POMPE
- ▼ TURBINA DI ASPIRAZIONE
- ▼ NUOVO BIDONE IN ACCIAIO INOX
- ▼ ALIMENTAZIONE SERBATOIO ACQUA IN AUTOMATICO
- ▼ AVVIAMENTO MANUALE A RICHIESTA
- ▼ COPERTURA IN ABS RESISTENTE AI RAGGI UV
- ▼ QUADRO ELETTRICO E GETTONIERA ELETTRONICA INTEGRATI
- ▼ DUE CONFIGURAZIONI DI USCITA DEL TUBO ASPIRATORE
 SINISTRA  DESTRA
- ▼ NECESSITA DI COLLEGAMENTO A RETE IDRICA
- ▼ PRODOTTO CHIMICO NON FORNITO
- ▼ VANDAL-PROOF DOORS AND LOCKS
- ▼ AUTOMATIC DISCHARGE BIN
- ▼ PUMPS CONTROL PRESSURE SWITCH
- ▼ VACUUM TURBINE
- ▼ NEW STAINLESS STEEL BIN
- ▼ AUTOMATIC WATER TANK SUPPLY
- ▼ MANUAL START ON DEMAND
- ▼ ABS COVER, RESISTANT TO UV RAYS
- ▼ INTEGRATED ELECTRONIC CONTROL BOARD
- ▼ TWO CONFIGURATIONS FOR VACUUM HOSE OUTLET
 LEFT  RIGHT
- ▼ WATER CONNECTION REQUIRED
- ▼ CHEMICAL PRODUCT NOT INCLUDED

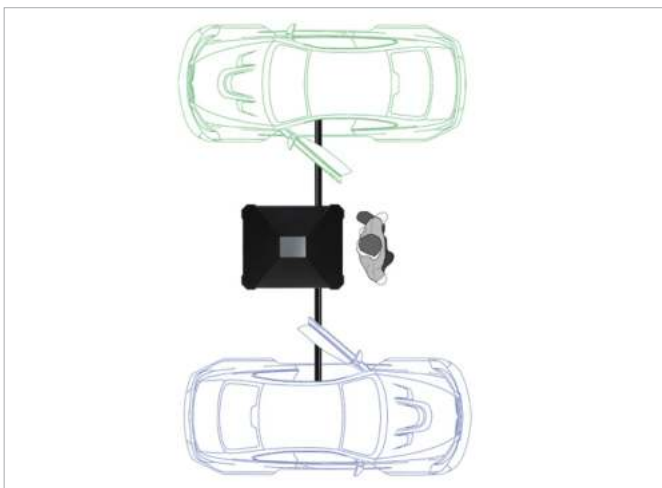

ACCESSORI IN DOTAZIONE / SUPPLIED ACCESSORIES

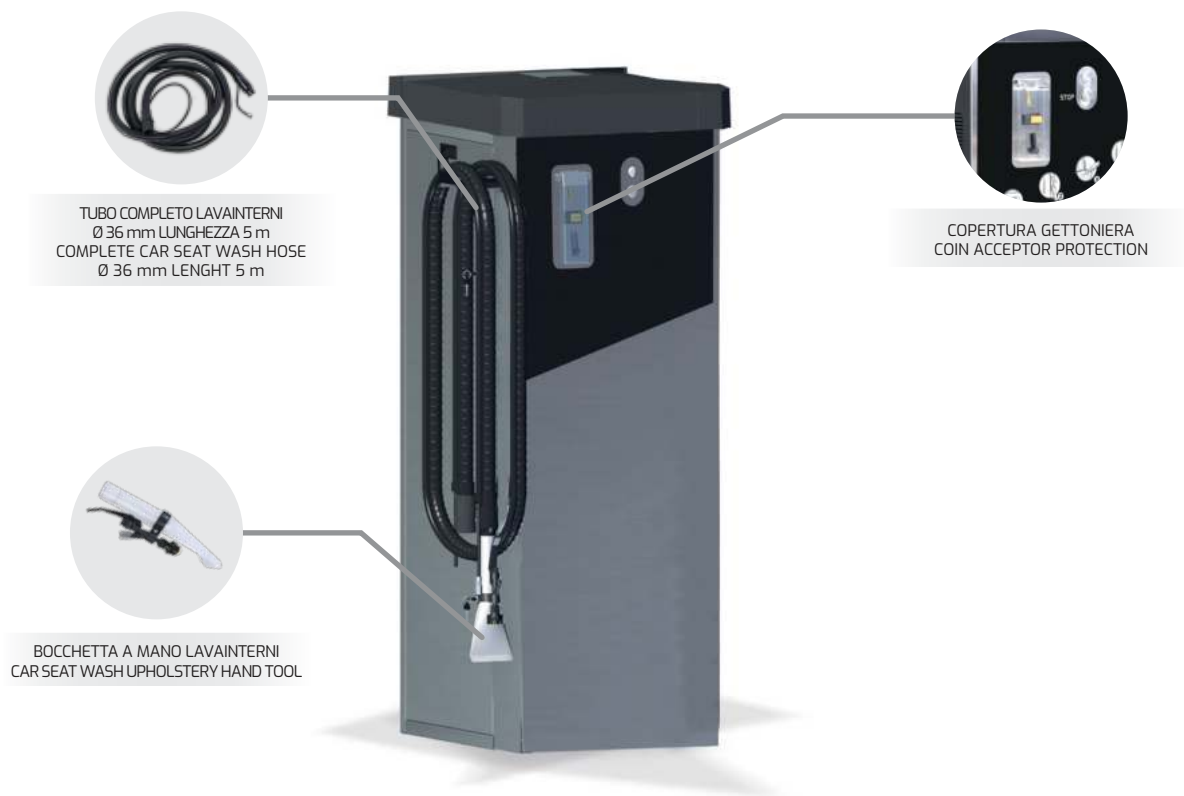

ACCESSORI A RICHIESTA / ACCESSORIES ON DEMAND

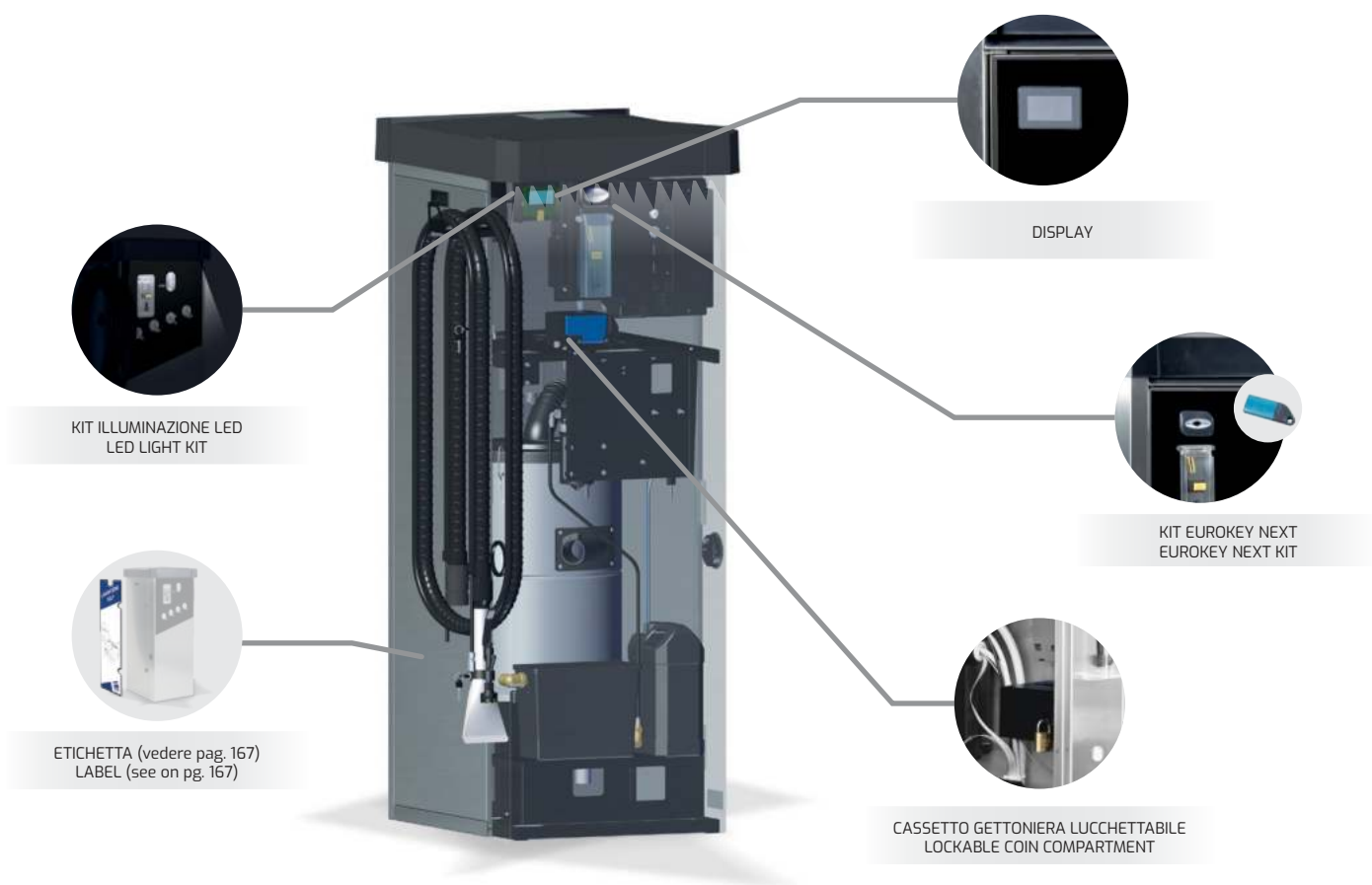

CARATTERISTICHE TECNICHE / TECHNICAL FEATURES

Codice Part No.	Potenza Power	Tensione Voltage	Portata d'Aria Air flow	Peso Totale Total Weight
3030510001	1,5 kW	230V - 50 Hz	250 m ³ /h	100 kg
3030520001	2,2 kW	400 V - 50 Hz	270 m ³ /h	100 kg

ACCESSORI IN DOTAZIONE / SUPPLIED ACCESSORIES

Codice Part No.	Descrizione Description
0964611005	TUBO COMPLETO LAVAINTERNI Ø 36 mm LUNGHEZZA 5 m CAR SEAT WASH FLEXIBLE HOSE Ø 36 mm LENGHT 5 m
0090027004	BOCCHETTA A MANO LAVAINTERNI CAR SEAT UPHOLSTERY HAND TOOL
0235020005	COPERTURA GETTONIERA COIN ACCEPTOR PROTECTION

ACCESSORI A RICHIESTA / ACCESSORIES ON DEMAND

Codice Part No.	Descrizione Description
0495022001	KIT EUROKEY NEXT EUROKEY NEXT KIT
0445611047	KIT ILLUMINAZIONE LED LED LIGHT KIT
0170242011	CASSETTO GETTONIERA LUCCHETTABILE LOCKABLE COIN COMPARTMENT
0445611050	DISPLAY
--	ETICHETTA (vedere pag. 179) LABEL (see on pg. 179)

PRINCIPIO DI FUNZIONAMENTO / WORKING SYSTEM

DIMENSIONI
DIMENSIONSIMBALLO (PALLET LEGNO + PLURIBALL)
PACKAGING (WOOD PALLET + PLURIBALL)SCHEMA DI FISSAGGIO BASAMENTO
INSTALLATION SCHEME

A (mm)	B (mm)	C (mm)	X (mm)	Y (mm)	Z (mm)	D (mm)	E (mm)
592	714	1570	900	1700	800	453	600

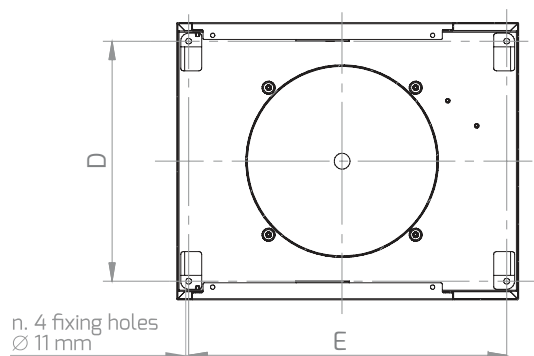
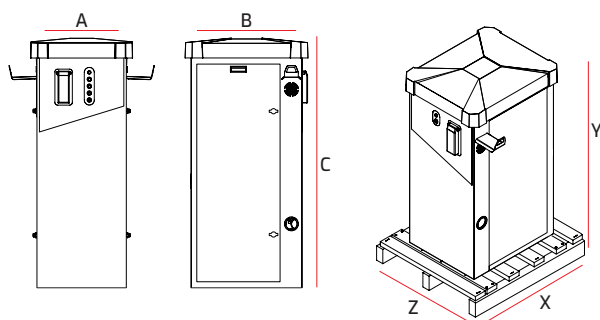









AL WET

LAVAITERNI SELF INIEZIONE · ESTRAZIONE / INJECTION · EXTRACTION CAR SEAT WASH

CARATTERISTICHE / FEATURES

- ▲ CHIUSURA A DUE PUNTI ANTIVANDALO
- ▲ BIDONI IN ACCIAIO INOX
- ▲ AVVIAMENTO MANUALE A RICHIESTA
- ▲ COPERTURA IN ABS RESISTENTE AI RAGGI UV
- ▲ QUADRO ELETTRICO E GETTONIERA ELETTRONICA INTEGRATI
- ▲ TRE CONFIGURAZIONI DI USCITA DEL TUBO ASPIRATORE
 SINISTRA
  DESTRA
  RETRO
- ▲ SPORTELLI ANTERIORI E POSTERIORI FACILMENTE RIMOVIBILI PER INTERVENTI DI MANUTENZIONE
- ▲ PRODOTTO CHIMICO NON FORNITO
- ▲ VANDAL-PROOF DOORS AND LOCKS
- ▲ STAINLESS STEEL BINS
- ▲ MANUAL START ON DEMAND
- ▲ ABS COVER, RESISTANT TO UV RAYS
- ▲ INTEGRATED ELECTRONIC CONTROL BOARD
- ▲ THREE CONFIGURATIONS FOR VACUUM HOSE OUTLET
 LEFT
  RIGHT
  BACK
- ▲ FRONT AND REAR COVER PANELS EASY TO REMOVE FOR MAINTENANCE OPERATIONS
- ▲ CHEMICAL PRODUCT NOT INCLUDED

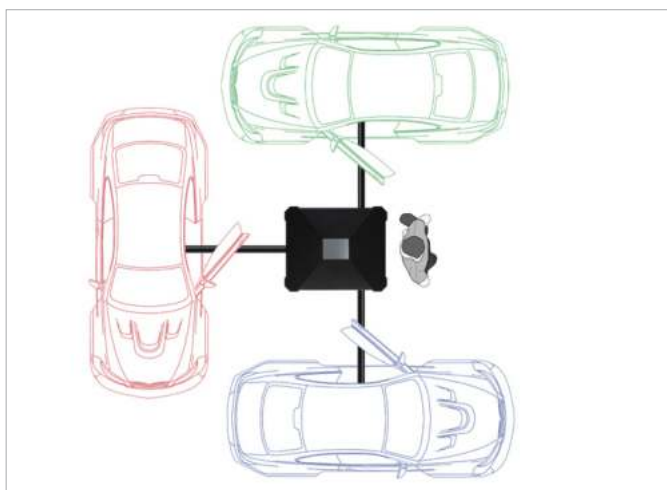

ACCESSORI IN DOTAZIONE / SUPPLIED ACCESSORIES



ACCESSORI A RICHIESTA / ACCESSORIES ON DEMAND

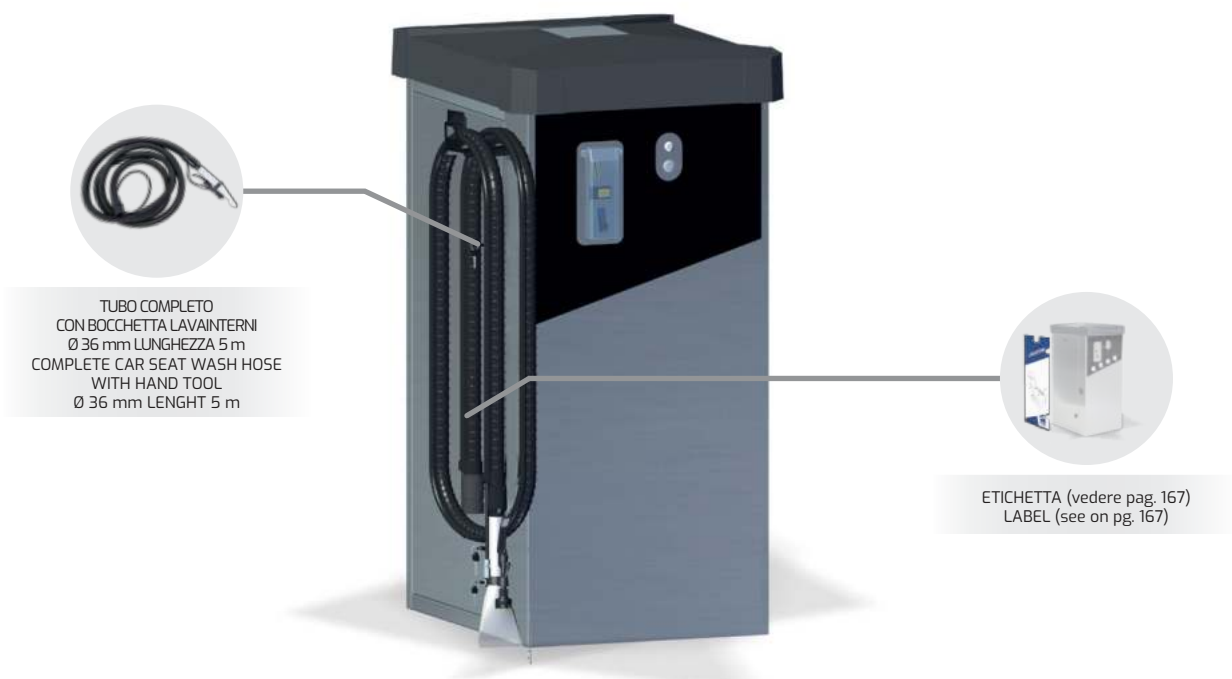

CARATTERISTICHE TECNICHE / TECHNICAL FEATURES

Codice Part No.	Potenza Power	Tensione Voltage	Portata d'Aria Air flow	Peso Totale Total Weight
3030450001	1,3 kW	230 V - 50 Hz	220 m ³ /h	50 kg

ACCESSORI IN DOTAZIONE / SUPPLIED ACCESSORIES

Codice Part No.	Descrizione Description
0964020005	TUBO Ø 36 mm LUNGHEZZA 3 m CON BOCCHETTA A MANO LAVAINTERNI CAR SEAT WASH HOSE Ø 36 mm LENGHT 3 m WITH UPHOLSTERY HAND TOOL
0942611002	TESTATA ASPIRATORE CON BIDONE LAVAINTERNI VACUUM HEAD WITH BIN FOR SEAT WASH
0235020005	COPERTURA GETTONIERA COIN ACCEPTOR PROTECTION

ACCESSORI A RICHIESTA / ACCESSORIES ON DEMAND

Codice Part No.	Descrizione Description
0964611007	TUBO COMPLETO CON BOCCHETTA LAVAINTERNI Ø 36 mm LUNGHEZZA 5 m CAR SEAT WASH FLEXIBLE HOSE WITH HAND TOOL Ø 36 mm LENGHT 5 m
--	ETICHETTA (vedere pag. 179) LABEL (see on pg. 179)

PRINCIPIO DI FUNZIONAMENTO / WORKING SYSTEM

DIMENSIONI
DIMENSIONSIMBALLO (PALLET LEGNO + PLURIBALL)
PACKAGING (WOOD PALLET + PLURIBALL)SCHEMA DI FISSAGGIO BASAMENTO
INSTALLATION SCHEME

A (mm)	B (mm)	C (mm)	X (mm)	Y (mm)	Z (mm)	D (mm)	E (mm)
592	714	1198	900	1328	800	453	600

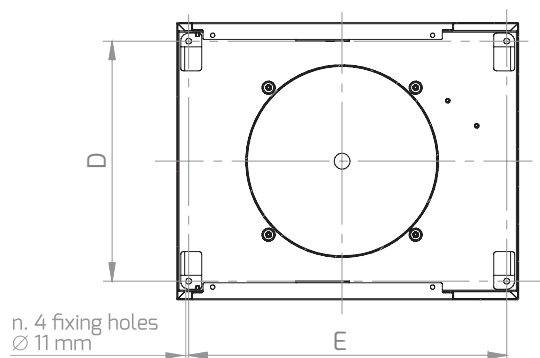
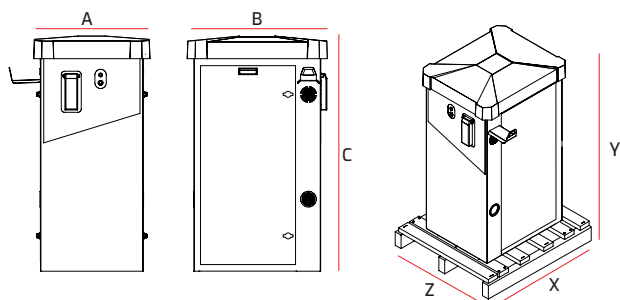



LAVINTERNI
SELF



MTM
HYDRO
CAR WASH EQUIPMENT

ASPIR



04 **DISTRIBUTORI PRODOTTI IN ROTOLO** ROLL PRODUCTS DISTRIBUTORS

01**RDC** DISTRIBUTORE PANNO UMIDIFICABILE · HUMIDIFIABLE CLOTH DISTRIBUTOR

081

02**RD SKIN/PAPER** DISTRIBUTORE PELLE/CARTA IN ROTOLO · ROLL SKIN/PAPER DISTRIBUTOR

085



L'**ACCIAIO INOX** che utilizziamo per le nostre macchine è del tipo AISI 304 quindi a basso contenuto di carbonio.
I principali vantaggi di questo materiale per le nostre applicazioni sono :

- Elevata resistenza alle intemperie e corrosione
- Facilità di ripulitura e ottimo coefficiente igienico.

*The **STAINLESS STEEL** used in the construction of our machines is of the type AISI 304 with low carbon content.*

The main advantages of this material for our applications are:

- High level of resistance to extreme weather and corrosion
- Ease of cleaning and maintenance and excellent hygiene properties.



La **SCHEDA ELETTRONICA**, dotata di temporizzatore elettronico, svolge una o più azioni a intervalli di tempo prefissati, facilmente regolabile secondo le esigenze del cliente.

*The **ELECTRONIC CIRCUIT BOARD**, supplied with an electronic timer, manages one or more functions at prefixed intervals, and is easily adjustable according to the client's needs.*



La **GETTONIERA ELETTRONICA**, offerta di serie, combina una straordinaria selettività ad un'estrema versatilità di programmazione.

*The **ELECTRONIC TOKEN AND COIN-OP** mechanism, supplied as standard equipment, combines extraordinary versatility with extreme programming flexibility.*



Il panno sintetico in rotolo è realizzato in un tessuto composto da micro livelli, adatto a qualsiasi operazione di pulizia delle superfici, possiede un'alta capacità di assorbimento, resistenza ai solventi ed è efficace sia su superfici asciutte che su superfici bagnate.

The synthetic cloths of the roll are made of a micro-level tissue; they are suitable for any surface cleaning operation offering a high absorption capacity, resistance to solvents and are effective for both wet and dry surfaces.



La **PELLE SINTETICA**, fornita in rotolo, offre caratteristiche

- facile pulizia
- idrorepellenza
- leggerezza
- resistenza all'usura

*The **SYNTHETIC LEATHER**, supplied in rolls, offers the following features:*

- easy cleaning
- water repellence
- lightweight
- wear resistance



La nostra macchina utilizza rotoli di **CARTA STANDARD** quindi facilmente reperibili presso qualsiasi rivenditore e/o grossista di materiale per pulizia.

*Our machines uses **STANDARD PAPER ROLLS** easily available at any wholesaler/retailer of cleaning materials.*

RDC	RD SKIN	RD PAPER
✓	✓	✓
✓	✓	✓
✓	✓	✓
✓		
	✓	
		✓



RDC

DISTRIBUTORE PANNO UMIDIFICABILE / HUMIDIFIABLE CLOTH DISTRIBUTOR

CARATTERISTICHE / FEATURES

- ▲ CHIUSURA A DUE PUNTI ANTIVANDALO
- ▲ QUADRO ELETTRICO E GETTONIERA INTEGRATI
- ▲ SPORTELLI ANTERIORI E POSTERIORI FACILMENTE RIMOVIBILI PER INTERVENTI DI MANUTENZIONE
- ▲ CALOTTA IN ABS RESISTENTE AI RAGGI UV
- ▲ POSSIBILITÀ DI MONTARE DIVERSI FORMATI DI ROTOLO (vedere pag.76)
- ▲ EROGAZIONE PANNO ED IRRORAZIONE PRODOTTO AUTOMATICAMENTE E SIMULTANEAMENTE
- ▲ SENSORE CON SPIA PER ALLARME MANCANZA PANNO
- ▲ LUNGHEZZA STRAPPO REGOLABILE (min. 380 mm max. 450 mm)
- ▲ QUANTITÀ IRRORAZIONE PRODOTTO REGOLABILE
- ▲ PRODOTTO CHIMICO NON FORNITO
- ▲ ROTOLO PANNO SINTETICO NON FORNITO
- ▲ VANDAL-PROOF DOORS AND LOCKS
- ▲ INTEGRATED CONTROL BOARD
- ▲ FRONT AND REAR COVER PANELS EASY TO REMOVE FOR MAINTENANCE OPERATIONS
- ▲ ABS COVER, RESISTANT TO UV RAYS
- ▲ POSSIBILITY OF MOUNTING DIFFERENT ROLL FORMATS (see on pg.76)
- ▲ DISPENSING AND SPRAYING ROLL AUTOMATICALLY AND SIMULTANOUSLY
- ▲ SENSOR WITH LAMP FOR ALARM LACK OF CLOTH
- ▲ ADJUSTABLE CLOTH LENGTH (min. 380 mm max. 450 mm)
- ▲ ADJUSTABLE PRODUCT QUANTITY
- ▲ CHEMICAL PRODUCT NOT INCLUDED
- ▲ SYNTHETIC CLOTH ROLL NOT INCLUDED



LA MACCHINA CON 1 CREDITO
EROGA UNA DELLE SEGUENTI OPZIONI:

- N. 2 PANNI ASCIUTTI
- N. 1 PANNO ASCIUTTO + PRODOTTO CRUSCOTTO
- N. 1 PANNO ASCIUTTO + PRODOTTO LAVAVETRI
- N. 1 PANNO ASCIUTTO + PRODOTTO FASCIONI

THE MACHINE DISPENSES ONE OF THE FOLLOWING OPTIONS
WITH 1 CREDIT:

- N. 2 DRY CLOTHS
- N. 1 DRY CLOTH + DASHBOARD PRODUCT
- N. 1 DRY CLOTH + WINDSHIELD WASHER PRODUCT
- N. 1 DRY CLOTH + SIDEBOARD PRODUCT



ACCESSORI A RICHIESTA / ON DEMAND ACCESSORIES

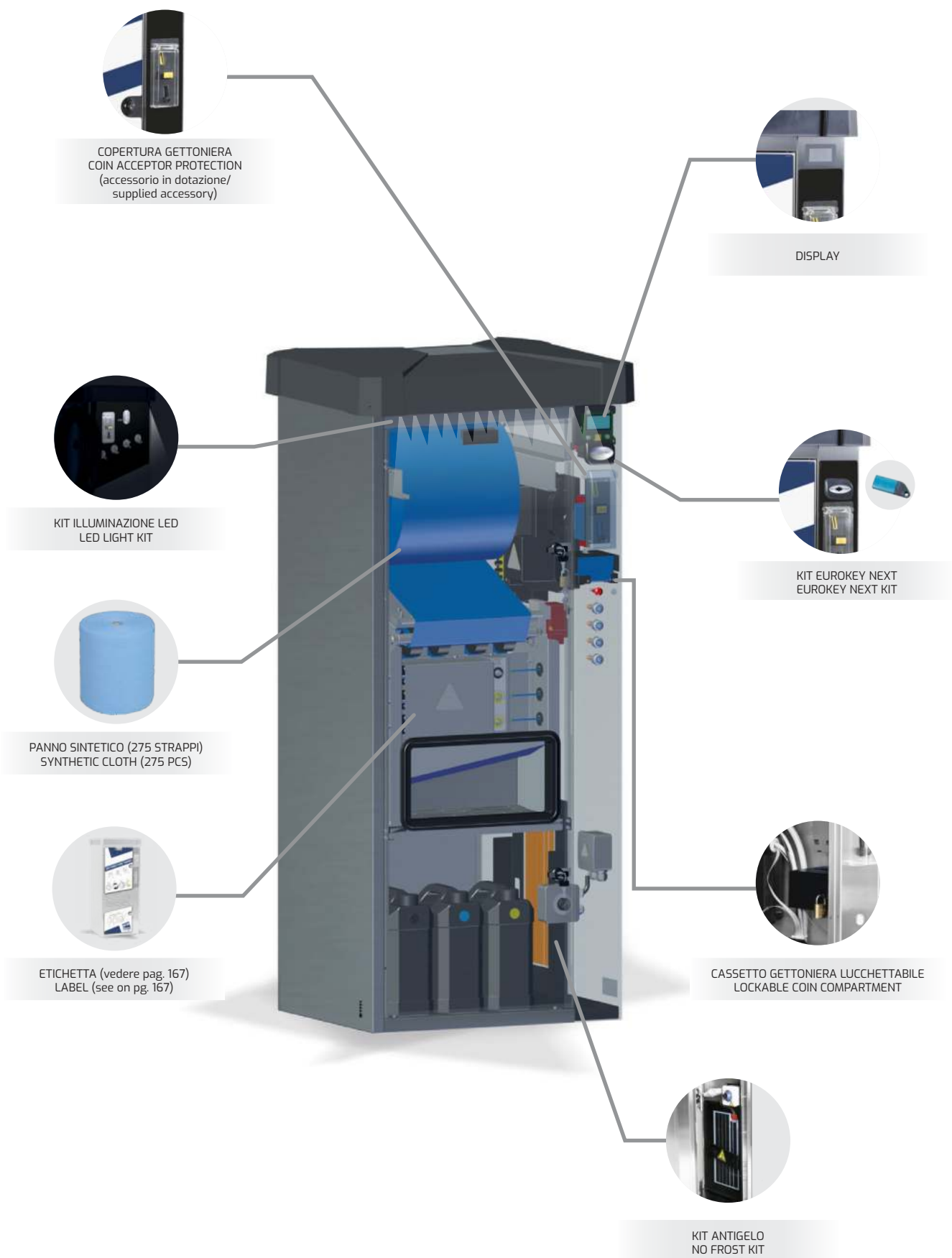

CARATTERISTICHE TECNICHE / TECHNICAL FEATURES

Codice Part No.	Potenza Power	Tensione Voltage	Pompa Pump	Peso Weight
3060510001	300W	230 V - 50 Hz	3 x 65W	80 kg

ACCESSORI IN DOTAZIONE / SUPPLIED ACCESSORIES

Codice Part No.	Descrizione Description
0235020005	COPERTURA GETTONIERA COIN ACCEPTOR PROTECTION

ACCESSORI A RICHIESTA / ACCESSORIES ON DEMAND

Codice Part No.	Descrizione Description
0625020001	PANNO SINTETICO (275 strappi) SYNTHETIC CLOTH (275 pieces)
0445611046	KIT ANTIGELO NO FROST KIT
0495022001	KIT EUROKEY NEXT EUROKEY NEXT KIT
0445611047	KIT ILLUMINAZIONE LED LED LIGHT KIT
0170242012	CASSETTO GETTONIERA LUCCHETTABILE LOCKABLE COIN COMPARTMENT
0445611050	DISPLAY
--	ETICHETTA (vedere pag. 179) LABEL (see on pg. 179)

DIMENSIONI ROLOLO / ROLL DIMENSIONS

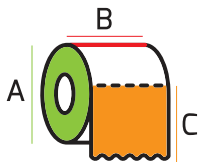

	MIN	MAX
A	--	ø 500 mm
B	240 mm	350 mm
C	380 mm	450 mm

DIMENSIONI
DIMENSIONSIMBALLO (PALLET LEGNO + PLURIBALL)
PACKAGING (WOOD PALLET + PLURIBALL)SCHEMA DI FISSAGGIO BASAMENTO
INSTALLATION SCHEME

A (mm)	B (mm)	C (mm)	X (mm)	Y (mm)	Z (mm)	D (mm)	E (mm)
592	714	1570	900	1700	800	453	600

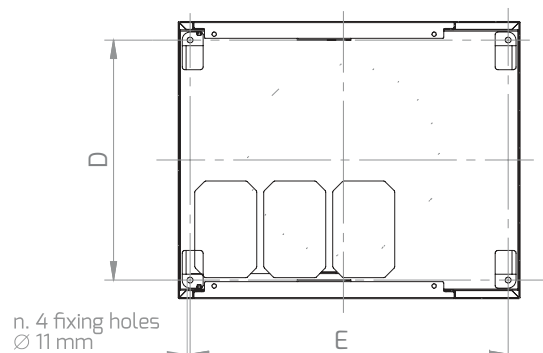
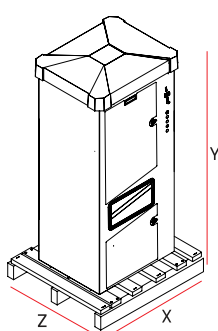
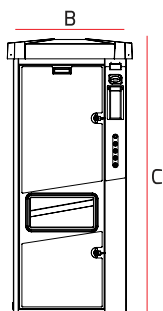
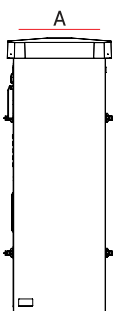

INOX
304

RD SKIN - RD PAPER

DISTRIBUTORE PELLE/CARTA IN ROTOLO / ROLL SKIN/PAPER DISTRIBUTOR

CARATTERISTICHE / FEATURES

- ▲ CHIUSURA A DUE PUNTI ANTIVANDALO
- ▲ QUADRO ELETTRICO E GETTONIERA INTEGRATI
- ▲ SPORTELLI ANTERIORI E POSTERIORI FACILMENTE RIMOVIBILI PER INTERVENTI DI MANUTENZIONE
- ▲ CALOTTA IN ABS RESISTENTE AI RAGGI UV
- ▲ POSSIBILITÀ DI MONTARE DIVERSI FORMATI DI ROTOLO (vedere pag.80)
- ▲ SENSORE CON SPIA PER ALLARME MANCANZA PANNOCARTA
- ▲ LUNGHEZZA STRAPPO REGOLABILE PER "SKIN" (min. 380 mm - max. 450 mm)
- ▲ LUNGHEZZA STRAPPO REGOLABILE PER "PAPER" (min. 380 mm - max. 2900 mm)
- ▲ ROTOLO PELLE/CARTA NON FORNITO
- ▲ VANDAL-PROOF DOORS AND LOCKS
- ▲ INTEGRATED CONTROL BOARD
- ▲ FRONT AND REAR COVER PANELS EASY TO REMOVE FOR MAINTENANCE OPERATIONS
- ▲ ABS COVER, RESISTANT TO UV RAYS
- ▲ POSSIBILITY OF MOUNTING DIFFERENT ROLL FORMATS (see on pg.80)
- ▲ SENSOR WITH LAMP FOR ALARM LACK OF CLOTH/PAPER
- ▲ ADJUSTABLE "SKIN" LENGTH (min. 380 mm - max. 450 mm)
- ▲ ADJUSTABLE "PAPER" LENGTH (min. 380 mm - max. 2900 mm)
- ▲ CLOTH/PAPER ROLL NOT INCLUDED



ACCESSORI A RICHIESTA / ON DEMAND ACCESSORIES



COPERTURA GETTONIERA
COIN ACCEPTOR PROTECTION
(accessorio in dotazione/
supplied accessory)



DISPLAY



KIT ILLUMINAZIONE LED
LED LIGHT KIT



KIT EUROKEY NEXT
EUROKEY NEXT KIT



PELLE SINTETICA (200 STRAPPI) - RD SKIN
SYNTHETIC CLOTH (200 PCS) - RD SKIN



CASSETTO GETTONIERA LUCCHETTABILE
LOCKABLE COIN COMPARTMENT



ETICHETTA (vedere pag. 167)
LABEL (see on pg. 167)

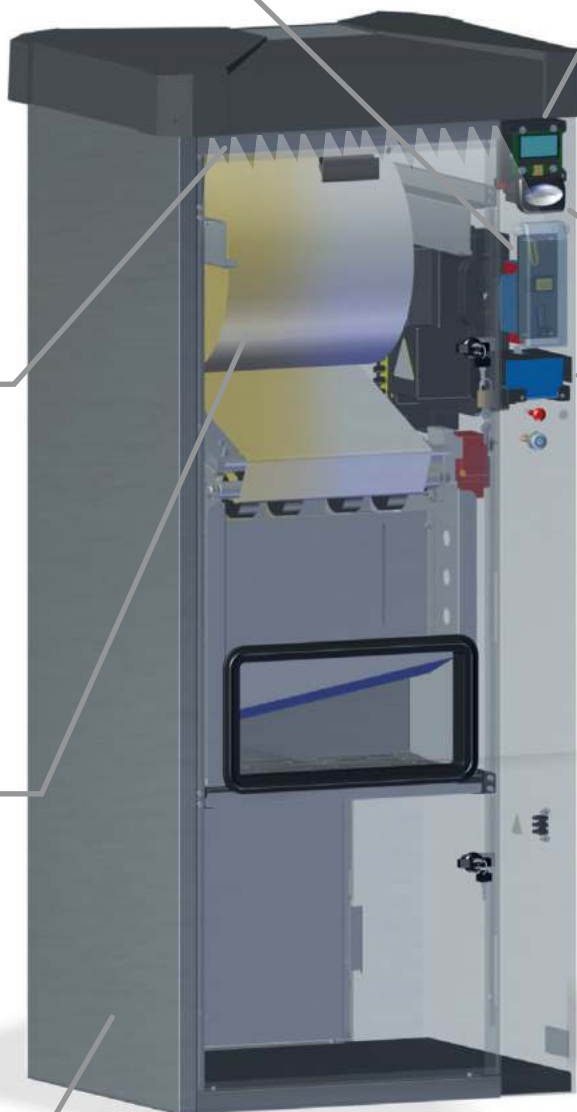

CARATTERISTICHE TECNICHE / TECHNICAL FEATURES

Codice Part No.	Modello Model	Potenza Power	Tensione Voltage	Peso Weight
3060410010	RD SKIN	110W	230 V - 50 Hz	75 kg
3060410001	RD PAPER	110W	230 V - 50 Hz	75 kg

ACCESSORI IN DOTAZIONE / SUPPLIED ACCESSORIES

Codice Part No.	Descrizione Description
0235020005	COPERTURA GETTONIERA COIN ACCEPTOR PROTECTION

ACCESSORI A RICHIESTA / ACCESSORIES ON DEMAND

Codice Part No.	Descrizione Description
0780020001	PELLE SINTETICA (200 strappi)-MODELLO RD SKIN SYNTHETIC CLOTH (200 pieces)-RD SKIN MODEL
0495022001	KIT EUROKEY NEXT EUROKEY NEXT KIT
0445611047	KIT ILLUMINAZIONE LED LED LIGHT KIT
0170242012	CASSETTO GETTONIERA LUCCHETTABILE LOCKABLE COIN COMPARTMENT
0445611050	DISPLAY
--	ETICHETTA (vedere pag. 179) LABEL (see on pg. 179)

DIMENSIONI ROLOLO / ROLL DIMENSIONS

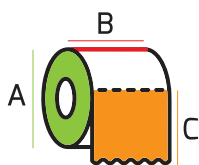

	MIN	MAX (skin)	MAX (paper)
A	--	ø 500 mm	ø 500 mm
B	240 mm	350 mm	350 mm
C	380 mm	450 mm	2900 mm

DIMENSIONI
DIMENSIONSIMBALLO (PALLET LEGNO + PLURIBALL)
PACKAGING (WOOD PALLET + PLURIBALL)SCHEMA DI FISSAGGIO BASAMENTO
INSTALLATION SCHEME

A (mm)	B (mm)	C (mm)	X (mm)	Y (mm)	Z (mm)	D (mm)	E (mm)
592	714	1570	900	1700	800	453	600

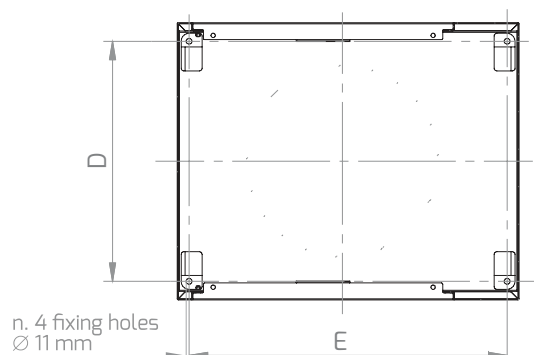
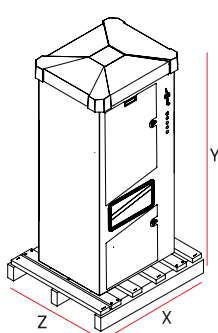
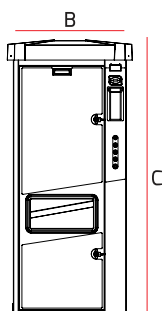
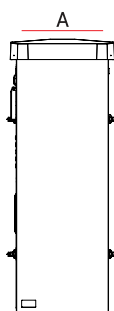





05 GONFIAGOMME

TIRE INFLATORS

01 TI ANALOGIC/DIGITAL - HTI DIGITAL GONFIAGOMME ANALOGICO/DIGITALE · ANALOGIC/DIGITAL TIRE INFLATOR 093

02 TI WATER - HTI WATER GONFIAGOMME ANALOGICO C/ACQUA · ANALOGIC TIRE INFLATOR W/WATER 097

03 LTI ANALOGIC/DIGITAL GONFIAGOMME ANALOGICO/ DIGITALE · ANALOGIC/DIGITAL TIRE INFLATOR 101



L'ACCIAIO INOX che utilizziamo per le nostre macchine è del tipo AISI 304 quindi a basso contenuto di carbonio.

I principali vantaggi di questo materiale per le nostre applicazioni sono :

- Elevata resistenza alle intemperie e corrosione
- Facilità di ripulitura e ottimo coefficiente igienico.

The STAINLESS STEEL used in the construction of our machines is of the type AISI 304 with low carbon content.

The main advantages of this material for our applications are:

- High level of resistance to extreme weather and corrosion
- Ease of cleaning and maintenance and excellent hygiene properties.

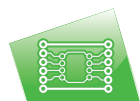

SCHEMA ELETTRONICA, dotata di temporizzatore elettronico, svolge una o più azioni a intervalli di tempo prefissati, facilmente regolabile secondo le esigenze del cliente.

The ELECTRONIC CIRCUIT BOARD, supplied with an electronic timer, manages one or more functions at prefixed intervals, and is easily adjustable according to the client's needs.



La **GETTONIERA ELETTRONICA**, offerta di serie, combina una straordinaria selettività ad un'estrema versatilità di programmazione.

The ELECTRONIC TOKEN AND COIN-OP mechanism, supplied as standard equipment, combines extraordinary versatility with extreme programming flexibility.



IL **MANOMETRO ANALOGICO** certificato, combina economicità a praticità e facilità d'uso.

The certified ANALOGICAL PRESSURE GAUGE, combines economic advantages, practicality and ease of use.



IL **DISPLAY DIGITALE** non è solo indicatore di pressione ma una vera e propria unità autonoma in grado di effettuare automaticamente le operazioni di gonfiaggio e sgonfiaggio dei pneumatici.

The DIGITAL DISPLAY is not only a pressure indicator, but also an authentic autonomous unit capable of automatically carrying out the functions of tire inflation and deflation.



Omologazione **PTB EN 12 645 (DE-19-M-PTB-0031)**: l'Istituto Tedesco PTB è uno dei principali enti di omologazione riconosciuti in Europa in campo Metrologico.

PTB approval EN 12 645 (DE-19-M-PTB-0031): PTB German is one of the main Europe approval bodies in Metrological applications.



Omologazione **LNE (16547 - 19532)**: l'Istituto Francese LNE è uno dei principali enti di omologazione riconosciuti in Europa in campo Metrologico.

LNE approval (16547 - 19532): LNE French is one of the main Europe approval bodies in Metrological applications.

TI - DIGITAL	HTI - DIGITAL	TI - WATER	HTI - WATER	TI - ANALOGIC	LT - ANALOGIC
✓	✓	✓	✓	✓	✓
✓	✓	✓	✓	✓	✓
✓	✓	✓	✓	✓	✓
	✓	✓	✓	✓	✓
✓	✓				
	✓		✓		
	✓		✓		



TI ANALOGIC



TI DIGITAL



HTI DIGITAL

TI ANALOGIC-DIGITAL / HTI DIGITAL
 GONFIAGOMME ANALOGICO-DIGITALE / ANALOGIC-DIGITAL TIRE INFLATOR

CARATTERISTICHE / FEATURES

- ▲ MODELLO HTI: OMOLOGAZIONE PTB EN 12 645 (DE-19-M-PTB-0031) OPPURE LNE (16547 - 19532)
- ▲ STRUTTURA PORTANTE MODULARE
- ▲ MANOMETRO ANALOGICO / DIGITALE CON OMOLOGAZIONI INTERNAZIONALI
- ▲ SISTEMA DI GONFIAGGIO AIRTEC MFD (VERSIONE HTI DIGITAL)
- ▲ CHIUSURA A DUE PUNTI ANTIVANDALO
- ▲ CONTENITORE GETTONI LUCCHETTABILE
- ▲ TEMPO CICLO PROGRAMMABILE
- ▲ AVVIAMENTO MANUALE A RICHIESTA
- ▲ CALOTTA IN ABS RESISTENTE AI RAGGI UV
- ▲ COMPRESSORE PROFESSIONALE VERTICALE CON COMODO ACCESSO ALLO SCARICO DELLA CONDENSA
- ▲ PANNELLI LATERALI E POSTERIORE DI COPERTURA FACILMENTE RIMOVIBILI PER INTERVENTI DI MANUTENZIONE
- ▲ QUADRO ELETTRICO E GETTONIERA INTEGRATI E DI FACILE ACCESSO
- ▲ HTI MODEL: PTB APPROVAL EN 12 645 (DE-19-M-PTB-0031) OR LNE (16547 - 19532)
- ▲ REINFORCED MODULAR FRAME
- ▲ ANALOGIC / DIGITAL PRESSURE GAUGE WITH INTERNATIONAL APPROVALS
- ▲ AIRTEC MFD INFLATION SYSTEM (HTI DIGITAL VERSION)
- ▲ VANDAL-PROOF DOORS AND LOCKS
- ▲ LOCKABLE TOKEN/COIN COMPARTMENT
- ▲ PROGRAMMABLE CYCLE TIME
- ▲ MANUAL START ON DEMAND
- ▲ ABS COVER, RESISTANT TO UV RAYS
- ▲ PROFESSIONAL VERTICAL COMPRESSOR (WHERE APPLICABLE) WITH EASY ACCESS TO CONDENSATION DRAIN
- ▲ LATERAL AND REAR COVER PANELS ARE EASY TO REMOVE FOR MAINTENANCE OPERATIONS
- ▲ EASY ACCESS INTEGRATED CONTROL BOARD



ACCESSORI IN DOTAZIONE / SUPPLIED ACCESSORIES

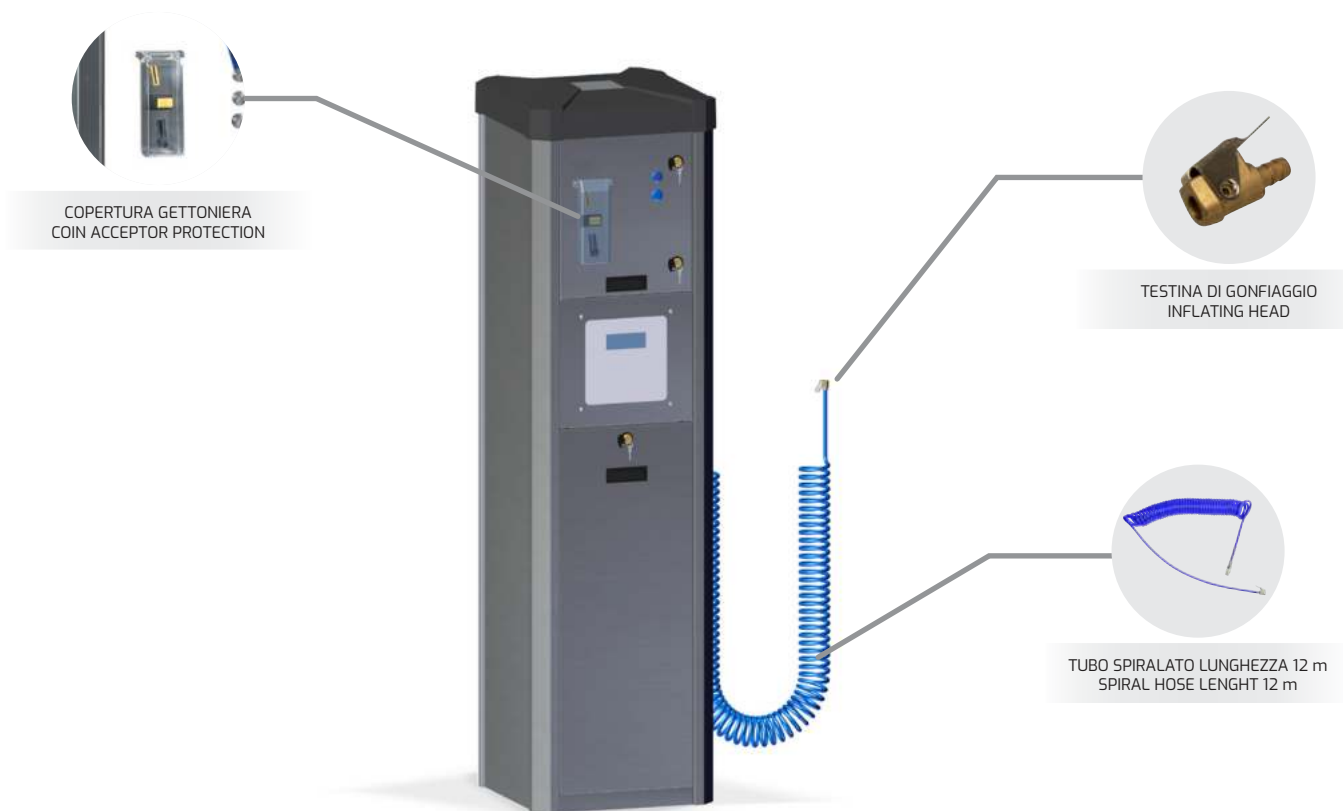

ACCESSORI A RICHIESTA / ACCESSORIES ON DEMAND

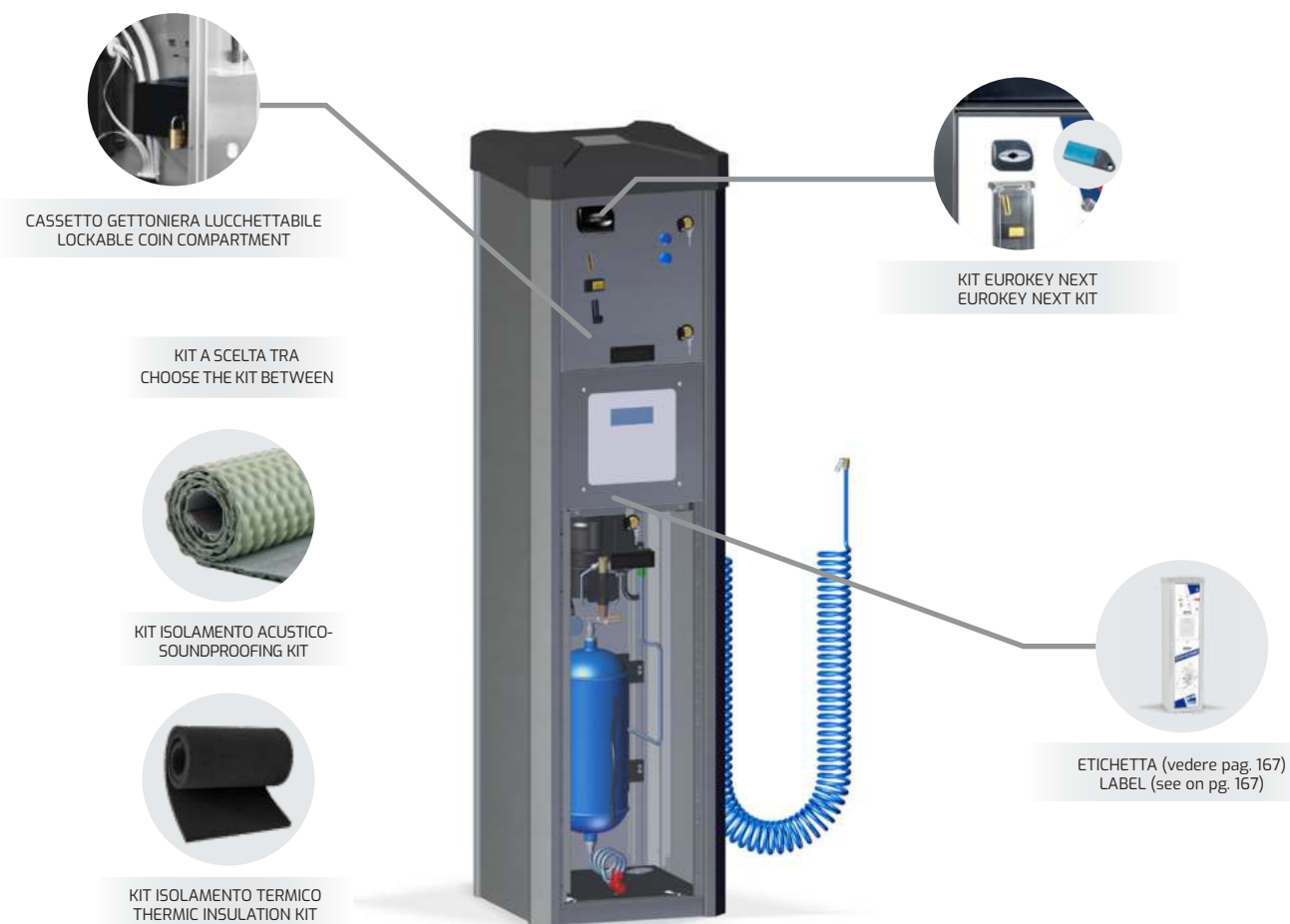

CARATTERISTICHE TECNICHE / TECHNICAL FEATURES

Codice Part No.	Modello Model	Omologazione Approval	Compressore Compressor	Potenza Power	Tensione Voltage	Portata d'Aria Air Flow	Pressione Aria Air Pressure	Peso Weight	Capacità Compressore Compressor Tank Capacity
3070110001	TI ANALOGIC			50W	230 V - 50 Hz		max 8 bar	45 kg	
3070110002 *	TI ANALOGIC		✓	450W	230 V - 50 Hz	100 l/min	max 5,5 bar	55 kg	6 l
3070210001	TI DIGITAL			50W	230 V - 50 Hz		max 5,5 bar	45 kg	
3070210002 *	TI DIGITAL		✓	450W	230 V - 50 Hz	100 l/min	max 5,5 bar	55 kg	6 l
3070610010	HTI DIGITAL	PTB		50W	230 V - 50 Hz		max 5,5 bar	45 kg	
3070610011*	HTI DIGITAL	PTB	✓	450W	230 V - 50 Hz	100 l/min	max 5,5 bar	55 kg	6 l
3070610016	HTI DIGITAL	LNE		50W	230 V - 50 Hz		max 5,5 bar	45 kg	
3070610017*	HTI DIGITAL	LNE	✓	450W	230 V - 50 Hz	100 l/min	max 5,5 bar	55 kg	6 l

* LE MACCHINE CON COMPRESSORE NON SONO FORNIBILI IN MODALITÀ "FUNZIONAMENTO GRATUITO"

* THE MACHINES WITH COMPRESSOR ARE NOT AVAILABLE FOR FREE USE

ACCESSORI IN DOTAZIONE / SUPPLIED ACCESSORIES

ACCESSORI A RICHIESTA / ACCESSORIES ON DEMAND

Codice Part No.	Descrizione Description	Codice Part No.	Descrizione Description
0090020002	TESTINA DI GONFIAGGIO INFLATING HEAD	0705610004	KIT ISOLAMENTO ACUSTICO SOUNDPROOFING KIT
0875034007	TUBO SPIRALATO LUNGHEZZA 12 m SPIRAL HOSE LENGHT 12 m	0705610001	KIT ISOLAMENTO TERMICO HEAT INSULATION KIT
0235020005	COPERTURA GETTONIERA COIN ACCEPTOR PROTECTION	0495022001	KIT EUROKEY NEXT EUROKEY NEXT KIT
		--	ETICHETTA (vedere pag. 179) LABEL (see on pag. 179)

DIMENSIONI
DIMENSIONSIMBALLO (PALLET LEGNO + SCATOLA CARTONE)
PACKAGING (WOOD PALLET + CARTON BOX)SCHEMA DI FISSAGGIO BASAMENTO
INSTALLATION SCHEME

A (mm)	B (mm)	C (mm)	X (mm)	Y (mm)	Z (mm)	D (mm)	E (mm)
420	420	1550	1785	608	500	278	278

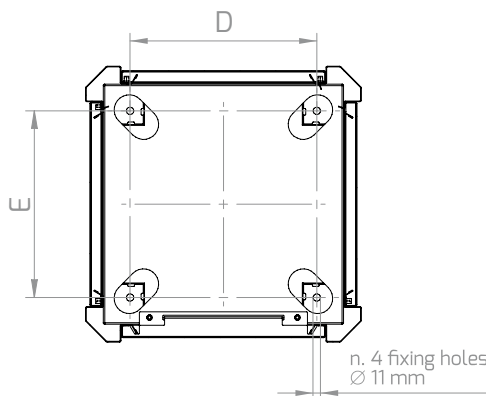
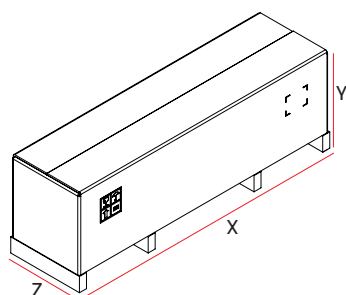
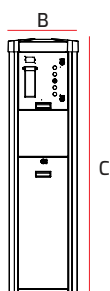
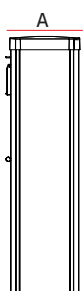



TI WATER / HTI WATER

GONFIAGOMME ANALOGICO-DIGITALE CON EROGAZIONE ACQUA / ANALOGIC-DIGITAL TIRE INFLATOR WITH WATER DISPENSER

CARATTERISTICHE / FEATURES

- ❖ MODELLO HTI: OMOLOGAZIONE PTB EN 12 645 (DE-19-M-PTB-0031) OPPURE LNE (16547 - 19532)
 - ❖ STRUTTURA PORTANTE MODULARE
 - ❖ MANOMETRO ANALOGICO
 - ❖ SISTEMA DI GONFIAGGIO AIRTEC MFD (VERSIONE HTI WATER)
 - ❖ CHIUSURA A DUE PUNTI ANTIVANDALO
 - ❖ CONTENITORE GETTONI LUCCHETTABILE
 - ❖ TEMPO CICLO PROGRAMMABILE
 - ❖ AVVIAMENTO MANUALE A RICHIESTA
 - ❖ CALOTTA IN ABS RESISTENTE AI RAGGI UV
 - ❖ COMPRESSORE PROFESSIONALE VERTICALE CON COMODO ACCESSO ALLO SCARICO DELLA CONDENSA
 - ❖ PANNELLI LATERALI E POSTERIORE DI COPERTURA FACILMENTE RIMOVIBILI PER INTERVENTI DI MANUTENZIONE
 - ❖ QUADRO ELETTRICO E GETTONIERA INTEGRATI E DI FACILE ACCESSO

 - ❖ HTI MODEL: PTB APPROVAL EN 12 645 (DE-19-M-PTB-0031) OR LNE (16547 - 19532)
 - ❖ REINFORCED MODULAR FRAME
 - ❖ ANALOGIC PRESSURE GAUGE
 - ❖ AIRTEC MFD INFLATION SYSTEM (HTI WATER VERSION)
 - ❖ VANDAL-PROOF DOORS AND LOCKS
 - ❖ LOCKABLE TOKEN/COIN COMPARTMENT
 - ❖ PROGRAMMABLE CYCLE TIME
 - ❖ MANUAL START ON DEMAND
 - ❖ ABS COVER, RESISTANT TO UV RAYS
 - ❖ PROFESSIONAL VERTICAL COMPRESSOR (WHERE APPLICABLE) WITH EASY ACCESS TO CONDENSATION DRAIN
 - ❖ LATERAL AND REAR COVER PANELS ARE EASY TO REMOVE FOR MAINTENANCE OPERATIONS
 - ❖ EASY ACCESS INTEGRATED CONTROL BOARD



ACCESSORI IN DOTAZIONE / SUPPLIED ACCESSORIES

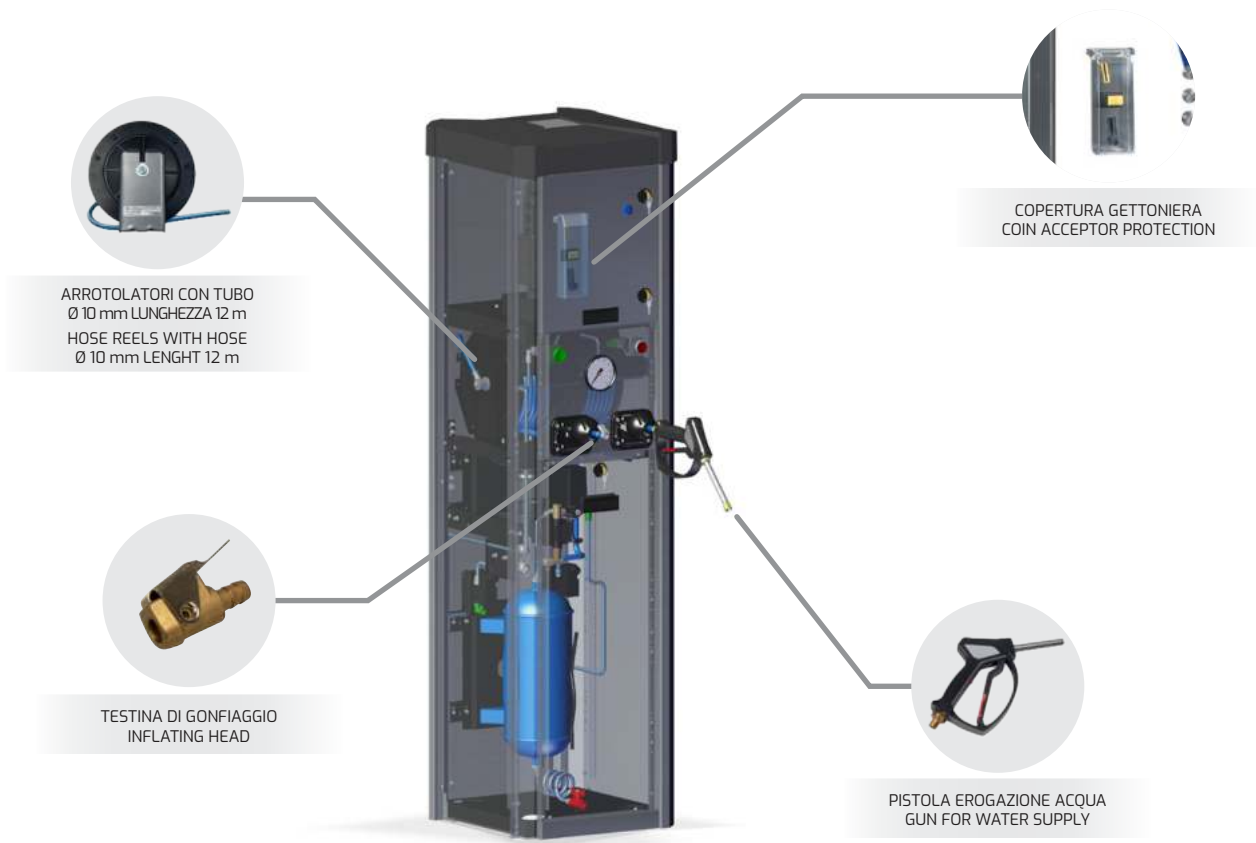

ACCESSORI A RICHIESTA / ACCESSORIES ON DEMAND

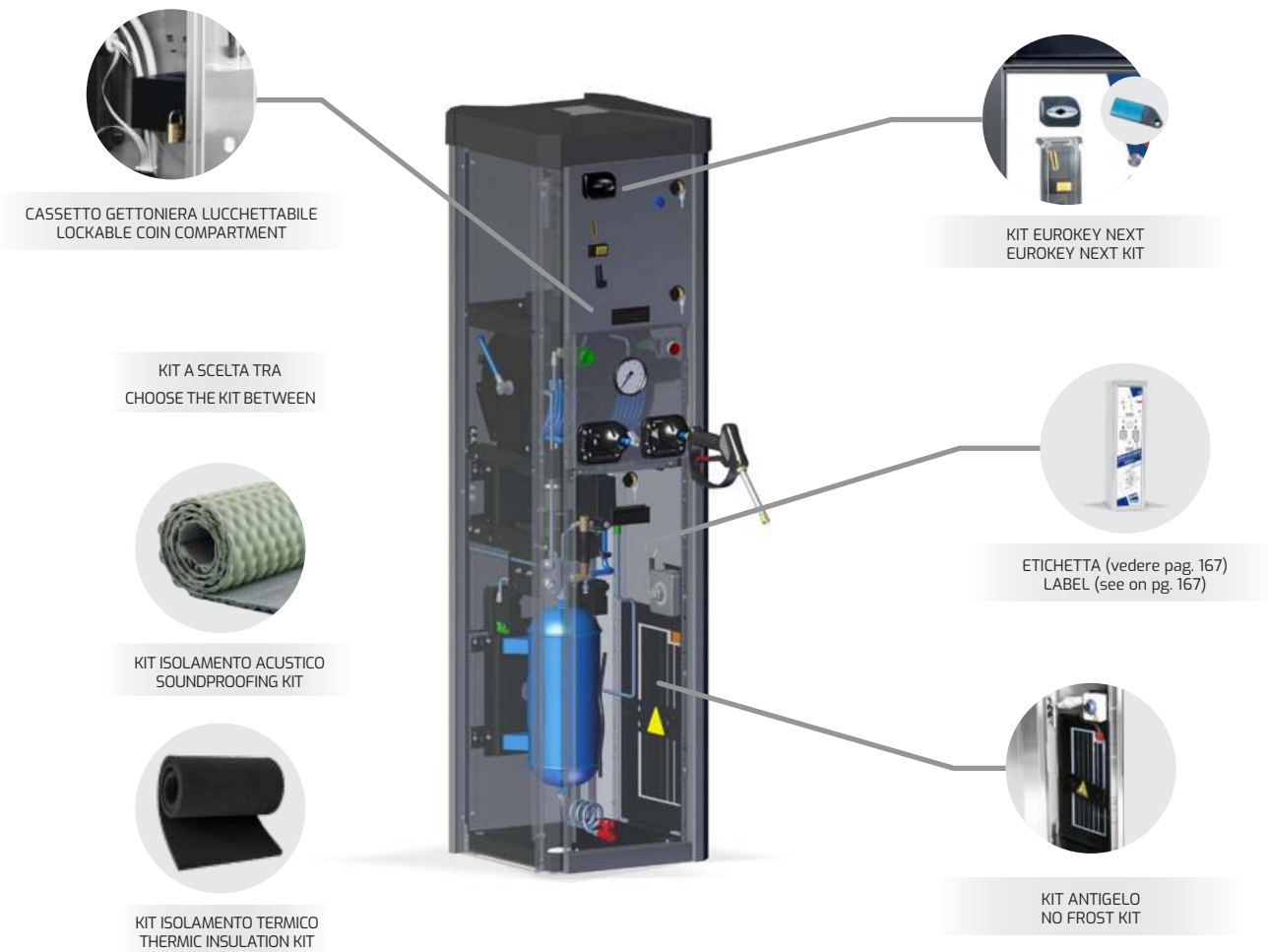

CARATTERISTICHE TECNICHE / TECHNICAL FEATURES

Codice Part No.	Modello Model	Omologazione Approval	Compressore Compressor	Potenza Power	Tensione Voltage	Portata d'Aria Air Flow	Pressione Aria Air Pressure	Peso Weight	Capacità Compressore Compressor Tank Capacity
3070310002	TI WATER			50W	230 V - 50 Hz		max 8 bar	45 kg	
3070310003*	TI WATER		✓	450W	230 V - 50 Hz	100 l/min	max 5,5 bar	55 kg	6 l
3070310011	HTIWATER	PTB		50W	230 V - 50 Hz		max 5,5 bar	45 kg	
3070310012*	HTIWATER	PTB	✓	450W	230 V - 50 Hz	100 l/min	max 5,5 bar	55 kg	6 l
3070310015	HTIWATER	LNE		50W	230 V - 50 Hz		max 5,5 bar	45 kg	
3070310016*	HTIWATER	LNE	✓	450W	230 V - 50 Hz	100 l/min	max 5,5 bar	55 kg	6 l

* LE MACCHINE CON COMPRESSORE NON SONO FORNIBILI IN MODALITÀ "FUNZIONAMENTO GRATUITO"

* THE MACHINES WITH COMPRESSOR ARE NOT AVAILABLE FOR FREE USE

ACCESSORI IN DOTAZIONE / SUPPLIED ACCESSORIES

Codice (1 pz.) Part No. (1 piece)	Descrizione Description	Quantità Quantity
0048020001	ARROTOLATORE CON TUBO Ø 10 mm LUNGHEZZA 12 m HOSE REELS WITH HOSE Ø 10 mm Length 12 m	2
0090020001	TESTINA DI GONFIAGGIO INFLATING HEAD	1
0937611002	PISTOLA EROGAZIONE ACQUA GUN FOR WATER SUPPLY	1
0235020005	COPERTURA GETTONIERA COIN ACCEPTOR PROTECTION	

ACCESSORI A RICHIESTA / ACCESSORIES ON DEMAND

Codice Part No.	Descrizione Description
0705610004	KIT ISOLAMENTO ACUSTICO SOUNDPROOFING KIT
0705610001	KIT ISOLAMENTO TERMICO HEAT INSULATION KIT
0445611003	KIT ANTIGELO NO FROST KIT
0495022001	KIT EUROKEY NEXT EUROKEY NEXT KIT
--	ETICHETTA (vedere pag. 179) LABEL (see on pg. 179)

MODELLO
MODELDIMENSIONI
DIMENSIONSIMBALLO (PALLET LEGNO + SCATOLA CARTONE)
PACKAGING (WOOD PALLET + CARTON BOX)SCHEMA DI FISSAGGIO BASAMENTO
INSTALLATION SCHEME

	A (mm)	B (mm)	C (mm)	X (mm)	Y (mm)	Z (mm)	D (mm)	E (mm)
TI WATER	420	420	1550	1785	608	500	278	278
HTI WATER	420	420	1750	1785	608	500	278	278

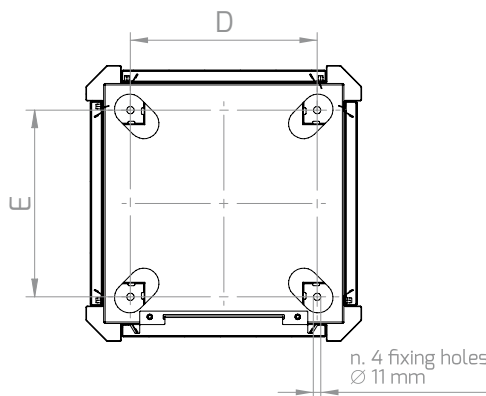
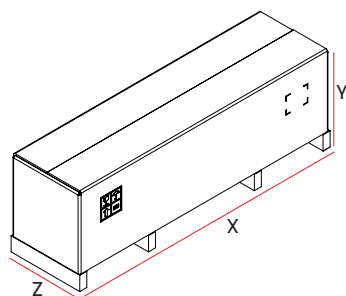
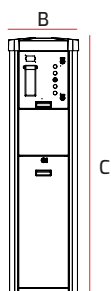
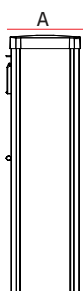



LTI ANALOGIC-DIGITAL

GONFIAGOMME ANALOGICO-DIGITALE / ANALOGIC-DIGITAL TIRE INFLATOR

CARATTERISTICHE / FEATURES

- ❖ CHIUSURA A DUE PUNTI ANTIVANDALO
 - ❖ MANOMETRO DIGITALE CON OMOLOGAZIONI INTERNAZIONALI
 - ❖ TEMPO CICLO PROGRAMMABILE
 - ❖ AVVIAMENTO MANUALE A RICHIESTA
 - ❖ CALOTTA IN ABS RESISTENTE AI RAGGI UV
 - ❖ QUADRO ELETTRICO E GETTONIERA INTEGRATI E DI FACILE ACCESSO
 - ❖ SPORTELLI ANTERIORI E POSTERIORI FACILMENTE RIMOVIBILI PER INTERVENTI DI MANUTENZIONE

 - ❖ VANDAL-PROOF DOORS AND LOCKS
 - ❖ DIGITAL PRESSURE GAUGE WITH INTERNATIONAL APPROVALS
 - ❖ PROGRAMMABLE CYCLE TIME
 - ❖ MANUAL START ON DEMAND
 - ❖ ABS COVER, RESISTANT TO UV RAYS
 - ❖ EASY ACCESS INTEGRATED CONTROL BOARD
 - ❖ FRONT AND REAR COVER PANELS EASY TO REMOVE FOR MAINTENANCE OPERATIONS



ACCESSORI IN DOTAZIONE / SUPPLIED ACCESSORIES



COPERTURA GETTONIERA
COIN ACCEPTOR PROTECTION

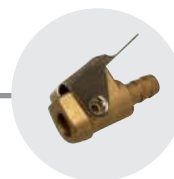

TESTINA DI GONFIAGGIO
INFLATING HEAD

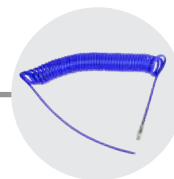

TUBO SPIRALATO LUNGHEZZA 12 m
SPIRAL HOSE LENGHT 12 m

ACCESSORI A RICHIESTA / ACCESSORIES ON DEMAND



KIT ILLUMINAZIONE LED
LED LIGHT KIT



ETICHETTA (vedere pag. 167)
LABEL (see on pg. 167)



KIT EUROKEY NEXT
EUROKEY NEXT KIT



CASSETTO GETTONIERA LUCCHETTABILE
LOCKABLE COIN COMPARTMENT

CARATTERISTICHE TECNICHE / TECHNICAL FEATURES

Codice Part No.	Modello Model	Compressore Compressor	Potenza Power	Tensione Voltage	Pressione Aria Air Pressure	Peso Weight
3070910001	LTI ANALOGIC		50W	230 V - 50 Hz	max 8 bar	30 kg
3070910006	LTI ANALOGIC	✓	450W	230 V - 50 Hz	max 8 bar	40 kg
3070910010	LTI DIGITAL		50W	230 V - 50 Hz	max 5,5 bar	30 kg
3070910011	LTI DIGITAL	✓	450W	230 V - 50 Hz	max 5,5 bar	40 kg

ACCESSORI IN DOTAZIONE / SUPPLIED ACCESSORIES

ACCESSORI A RICHIESTA / ACCESSORIES ON DEMAND

Codice Part No.	Descrizione Description	Codice Part No.	Descrizione Description
0090020002	TESTINA DI GONFIAGGIO INFLATING HEAD	0495022001	KIT EUROKEY NEXT EUROKEY NEXT KIT
0875034007	TUBO SPIRALATO LUNGHEZZA 12 m SPIRAL HOSE LENGHT 12 m	0170242011	CASSETTO GETTONIERA LUCCHETTABILE LOCKABLE COIN COMPARTMENT
0235020005	COPERTURA GETTONIERA COIN ACCEPTOR PROTECTION	0445611036	KIT ILLUMINAZIONE LED LED LIGHT KIT
		--	ETICHETTA (vedere pag. 179) LABEL (see on pg. 179)

DIMENSIONI
DIMENSIONSIMBALLO (SCATOLA CARTONE)
PACKAGING (CARTON BOX)SCHEMA DI FISSAGGIO BASAMENTO
INSTALLATION SCHEME

A (mm)	B (mm)	C (mm)	X (mm)	Y (mm)	Z (mm)	D (mm)	E (mm)
420	420	1410	1500	600	470	250	300

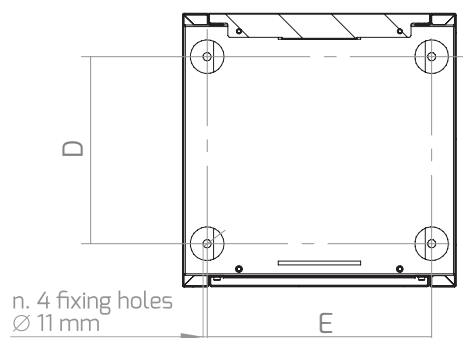
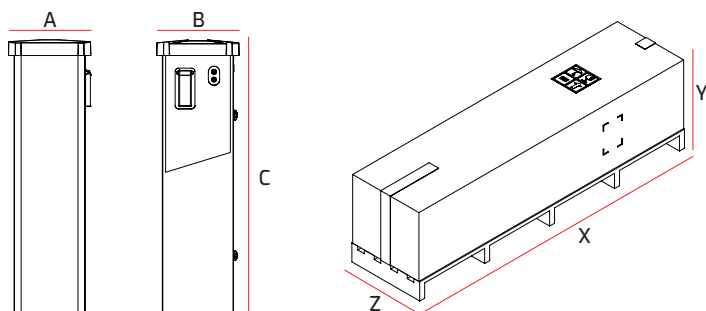





06 COLONNINE EROGATRICI DISPENSING COLUMNS

01 SD1 - SD2 - SD3 COLONNINE SINGOLO/DOPPIO/TRIPLO PRODOTTO · SINGLE/DOUBLE/TRIPLE PRODUCT COLUMNS 109

02 SD1 PARFUME PROFUMO AUTO · CAR PERFUME 115

03 LD1 - LD2 COLONNINE SINGOLO/DOPPIO PRODOTTO · SINGLE/DOUBLE PRODUCT COLUMNS 119

04 LD1 SANISPRAY EROGATORE DI PRODOTTO SANITIZZANTE NEBULIZZATO / DISPENSER OF NEBULIZED SANITIZING PRODUCT 123

05 WLD DISTRIBUTORE LIQUIDO LAVAVETRI · WINDSCREEN WIPER LIQUID DISPENSER 127



SD1 - SD2 - SD3

COLONNINE SINGOLO-DOPPIO-TRIPLO PRODOTTO / SINGLE-DOUBLE-TRIPLE PRODUCT COLUMNS

CARATTERISTICHE / FEATURES

- ▲ COLONNINE UNIVERSALI PER EROGAZIONE 1,2,3 SERVIZI/PRODOTTI VARI (ARIA COMPRESSA, PROFUMI, SANITIZZANTI, PRODOTTO CRUSCOTTO, ANTIBATTERICO, NEROGOMME, PRODOTTO CERCHI)
- ▲ UNIVERSAL COLUMNS DISPENSING 1,2,3 SERVICES/PRODUCTS (COMPRESSED AIR, FRAGRANCES, SANITIZERS, DASHBOARD PRODUCT, ANTIBACTERIAL, TIRE BLACKENING, RIM PRODUCT)
- ▲ SERVIZIO ARIA COMPRESSA SEMPRE FORNITO, NECESSITA DI COLLEGAMENTO A RETE PNEUMATICA (SD3)
- ▲ COMPRESSED AIR SERVICE ALWAYS SUPPLIED, REQUIRE A PNEUMATIC NETWORK CONNECTION (SD3)
- ▲ SODDISFA LE PIÙ SVARIATE NECESSITÀ UTILIZZANDO UNA SOLA MACCHINA A COSTI CONTENUTI
- ▲ SATISFY THE MOST DIVERSE NEED USING ONLY ONE MACHINE AT AFFORDABLE COSTS
- ▲ POSSIBILITÀ DI IMPOSTARE DUE TEMPI PRODOTTO DIVERSI (SD2-SD3)
- ▲ CHOICE OF TWO DIFFERENT PRODUCT TIME SETTINGS (SD2-SD3)
- ▲ PASSAGGIO DA UN PRODOTTO ALL'ALTRO CON UN SOLO GETTONE CON RICALCOLO DEL TEMPO RESIDUO (SD2-SD3)
- ▲ SWITCHING FROM ONE PRODUCT TO ANOTHER WITH ONE SINGLE TOKEN WITH THE RECALCULATION OF REMAINING TIME (SD2-SD3)
- ▲ STRUTTURA PORTANTE MODULARE
- ▲ REINFORCED MODULAR FRAME
- ▲ CHIUSURA A DUE PUNTI ANTIVANDALO
- ▲ VANDAL-PROOF DOORS AND LOCKS
- ▲ CONTENITORE GETTONI LUCCHETTABILE
- ▲ LOCKABLE TOKEN/COIN COMPARTMENT
- ▲ TEMPO CICLO PROGRAMMABILE
- ▲ PROGRAMMABLE CYCLE TIME
- ▲ AVVIAMENTO MANUALE A RICHIESTA
- ▲ MANUAL START ON DEMAND
- ▲ CALOTTA IN ABS RESISTENTE AI RAGGI UV
- ▲ ABS COVER, RESISTANT TO UV RAYS
- ▲ PANNELLI LATERALI E POSTERIORE DI COPERTURA FACILMENTE RIMOVIBILI PER INTERVENTI DI MANUTENZIONE
- ▲ LATERAL AND REAR COVER PANELS ARE EASY TO REMOVE FOR MAINTENANCE OPERATIONS
- ▲ QUADRO ELETTRICO E GETTONIERA INTEGRATI E DI FACILE ACCESSO
- ▲ EASY ACCESS INTEGRATED CONTROL BOARD
- ▲ PRODOTTI CHIMICI NON FORNITI
- ▲ CHEMICAL PRODUCTS NOT INCLUDED



ACCESSORI IN DOTAZIONE / SUPPLIED ACCESSORIES

SD1

KIT A SCELTA TRA UNO DEI SEGUENTI
CHOOSE THE KIT AMONG ONE OF THE FOLLOWING



COPERTURA GETTONIERA
COIN ACCEPTOR PROTECTION



CASSETTO GETTONIERA LUCCHETTABILE
LOCKABLE COIN COMPARTMENT



PISTOLA NEBULIZZATRICE
CON TUBO SPIRALATO LUNGHEZZA 6 m
SPRAY GUN
WITH SPIRAL HOSE LENGHT 6 m



PISTOLA NEROGOMME
CON TUBO SPIRALATO LUNGHEZZA 8 m
TIRE BLACKENING GUN
WITH SPIRAL HOSE LENGHT 8 m



PISTOLA PRODOTTO CERCHI
CON TUBO SPIRALATO LUNGHEZZA 8 m
RIM PRODUCT GUN
WITH SPIRAL HOSE LENGHT 8 m

ACCESSORI IN DOTAZIONE / SUPPLIED ACCESSORIES

SD2

DUE KIT A SCELTA TRA I SEGUENTI
CHOOSE TWO KITS AMONG THE FOLLOWING ONES



COPERTURA GETTONIERA
COIN ACCEPTOR PROTECTION



CASSETTO GETTONIERA LUCCHETTABILE
LOCKABLE COIN COMPARTMENT



PISTOLA ARIA COMPRESSA
CON TUBO SPIRALATO LUNGHEZZA 6 m
COMPRESSED AIR GUN
WITH SPIRAL HOSE LENGHT 6 m



PISTOLA NEBULIZZATRICE
CON TUBO SPIRALATO LUNGHEZZA 6 m
SPRAY GUN
WITH SPIRAL HOSE LENGHT 6 m



PISTOLA NEROGOMME
CON TUBO SPIRALATO LUNGHEZZA 8 m
TIRE BLACKENING GUN
WITH SPIRAL HOSE LENGHT 8 m



PISTOLA PRODOTTO CERCHI
CON TUBO SPIRALATO LUNGHEZZA 8 m
RIM PRODUCT GUN
WITH SPIRAL HOSE LENGHT 8 m

ACCESSORI IN DOTAZIONE / SUPPLIED ACCESSORIES

SD3



COPERTURA GETTONIERA
COIN ACCEPTOR PROTECTION



PISTOLA ARIA COMPRESSA
CON TUBO SPIRALATO LUNGHEZZA 6 m*
COMPRESSED AIR GUN
WITH SPIRAL HOSE LENGHT 6 m*

* SERVIZIO ARIA COMPRESSA SEMPRE FORNITO
* COMPRESSED AIR SERVICE ALWAYS SUPPLIED



CASSETTO GETTONIERA LUCCHETTABILE
LOCKABLE COIN COMPARTMENT



DUE KIT A SCELTA TRA I SEGUENTI
CHOOSE TWO KITS AMONG THE FOLLOWING ONES



PISTOLA NEBULIZZATRICE
CON TUBO SPIRALATO LUNGHEZZA 6 m
SPRAY GUN
WITH SPIRAL HOSE LENGHT 6 m



PISTOLA NEROGOMME
CON TUBO SPIRALATO LUNGHEZZA 8 m
TIRE BLACKENING GUN
WITH SPIRAL HOSE LENGHT 8 m



PISTOLA PRODOTTO CERCHI
CON TUBO SPIRALATO LUNGHEZZA 8 m
RIM PRODUCT GUN
WITH SPIRAL HOSE LENGHT 8 m

ACCESSORI A RICHIESTA / ACCESSORIES ON DEMAND

SD1-SD2-SD3



KIT ISOLAMENTO TERMICO
THERMIC INSULATION KIT



KIT ANTIGELO
NO FROST KIT



KIT EUROKEY NEXT
EUROKEY NEXT KIT



ETICHETTA (vedere pag. 167)
LABEL (see on pg. 167)

CARATTERISTICHE TECNICHE / TECHNICAL FEATURES

Codice Part No.	Mod. Model	Prodotto 1 Product 1	Pompa1 Pump 1	Prodotto 2 Product 2	Pompa2 Pump 2	Prodotto 3 Product 3	Pompa3 Pump 3	Erog. Prodotto Product Supply	Potenza Power	Tensione Voltage	Cap. Serb. Tank Cap.	Peso Weight
3080410001	SD1	SANITIZ. SANITIZER	ELETTR. ELECTR.	--	--	--	--	0,05 l/min	100W	230 V 50 Hz	25 l	30 kg
3081010002	SD1	NEROGOMME TIRE BLACKENING	INOX S. STEEL	--	--	--	--	0,3 l/min	250W	230 V 50 Hz	25 l	35 kg
3081010003	SD1	NEROGOMME TIRE BLACKENING	ELETTR. ELECTR.	--	--	--	--	0,05 l/min	100W	230 V 50 Hz	25 l	30 kg
3080910001	SD1	PROD.CERCHI RIM PROD.	INOX S. STEEL	--	--	--	--	0,3 l/min	250W	230 V 50 Hz	25 l	35 kg
3080910002	SD1	PROD.CERCHI RIM PROD.	ELETTR. ELECTR.	--	--	--	--	0,05 l/min	100W	230 V 50 Hz	25 l	30 kg
3081110001	SD2	ARIA COMPR. COMPR. AIR	--	SANITIZ. SANITIZER	ELETTR. ELECTR.	--	--	Pompa 2 0,05 l/min	100W	230 V 50 Hz	5 l	30 kg
3081310001	SD2	ARIA COMPR. COMPR. AIR	--	PROD.CRUSCOTTO DASHBOARDPOUSH	ELETTR. ELECTR.	--	--	Pompa 2 0,05 l/min	100W	230 V 50 Hz	5 l	30 kg
3081210001	SD2	ARIA COMPR. COMPR. AIR	--	PROD. CERCHI RIM PROD.	ELETTR. ELECTR.	--	--	Pompa 2 0,05 l/min	100W	230 V 50 Hz	5 l	30 kg
3081210002	SD2	ARIA COMPR. COMPR. AIR	--	PROD. CERCHI RIM PROD.	INOX S. STEEL	--	--	Pompa 2 0,3 l/min	250W	230 V 50 Hz	5 l	35 kg
3081410001	SD2	ARIA COMPR. COMPR. AIR	--	NEROGOMME TIRE BLACKENING	ELETTR. ELECTR.	--	--	Pompa 2 0,05 l/min	100W	230 V 50 Hz	5 l	30 kg
3081410002	SD2	ARIA COMPR. COMPR. AIR	--	NEROGOMME TIRE BLACKENING	INOX S. STEEL	--	--	Pompa 2 0,3 l/min	250W	230 V 50 Hz	5 l	35 kg
3081610001	SD2	SANITIZ. SANITIZER	ELETTR. ELECTR.	PROD.CRUSCOTTO DASHBOARDPOUSH	ELETTR. ELECTR.	--	--	Pompa 1 0,05 l/min Pompa 2 0,05 l/min	200W	230 V 50 Hz	2 x 5 l	30 kg
3081510002	SD2	PROD.CERCHI RIM PROD.	ELETTR. ELECTR.	SANITIZ. SANITIZER	ELETTR. ELECTR.	--	--	Pompa 1 0,05 l/min Pompa 2 0,05 l/min	200W	230 V 50 Hz	2 x 5 l	30 kg
3081810001	SD2	PROD.CERCHI RIM PROD.	ELETTR. ELECTR.	PROD. CRUSCOTTO DASHBOARDPOUSH	ELETTR. ELECTR.	--	--	Pompa 1 0,05 l/min Pompa 2 0,05 l/min	200W	230 V 50 Hz	2 x 5 l	30 kg
3081510003	SD2	PROD.CERCHI RIM PROD.	INOX S. STEEL	SANITIZ. SANITIZER	ELETTR. ELECTR.	--	--	Pompa 1 0,3 l/min Pompa 2 0,05 l/min	350W	230 V 50 Hz	2 x 5 l	35 kg
3081810002	SD2	PROD.CERCHI RIM PROD.	INOX S. STEEL	PROD. CRUSCOTTO DASHBOARDPOUSH	ELETTR. ELECTR.	--	--	Pompa 1 0,3 l/min Pompa 2 0,05 l/min	350W	230 V 50 Hz	2 x 5 l	35 kg
3081910001	SD2	PROD.CERCHI RIM PROD.	ELETTR. ELECTR.	NEROGOMME TIRE BLACKENING	ELETTR. ELECTR.	--	--	Pompa 1 0,05 l/min Pompa 2 0,05 l/min	200W	230 V 50 Hz	2 x 5 l	30 kg
3081910002	SD2	PROD.CERCHI RIM PROD.	INOX S. STEEL	NEROGOMME TIRE BLACKENING	ELETTR. ELECTR.	--	--	Pompa 1 0,3 l/min Pompa 2 0,05 l/min	350W	230 V 50 Hz	2 x 5 l	35 kg
3081710001	SD2	NEROGOMME TIRE BLACKENING	ELETTR. ELECTR.	SANITIZ. SANITIZER	ELETTR. ELECTR.	--	--	Pompa 1 0,05 l/min Pompa 2 0,05 l/min	200W	230 V 50 Hz	2 x 5 l	30 kg
3082010001	SD2	NEROGOMME TIRE BLACKENING	ELETTR. ELECTR.	PROD. CRUSCOTTO DASHBOARDPOUSH	ELETTR. ELECTR.	--	--	Pompa 1 0,05 l/min Pompa 2 0,05 l/min	200W	230 V 50 Hz	2 x 5 l	30 kg
3081710005	SD2	NEROGOMME TIRE BLACKENING	INOX S. STEEL	SANITIZ. SANITIZER	ELETTR. ELECTR.	--	--	Pompa 1 0,3 l/min Pompa 2 0,05 l/min	350W	230 V 50 Hz	2 x 5 l	35 kg
3082010002	SD2	NEROGOMME TIRE BLACKENING	INOX S. STEEL	PROD. CRUSCOTTO DASHBOARDPOUSH	ELETTR. ELECTR.	--	--	Pompa 1 0,3 l/min Pompa 2 0,05 l/min	350W	230 V 50 Hz	2 x 5 l	35 kg
3082110001	SD3	ARIA COMPR.* COMPR. AIR*		SANITIZZANTE SANITIZER	ELETTR. ELECTR.	PROD. CERCHI RIM PRODUCT	ELETTR. ELECTR.	Pompa 2 0,05 l/min Pompa 3 0,05 l/min	250 W	230 V 50 Hz	2 x 5 l	30 kg
3082410001	SD3	ARIA COMPR.* COMPR. AIR*		PROD. CRUSCOTTO DASHBOARDPOUSH	ELETTR. ELECTR.	PROD. CERCHI RIM PRODUCT	ELETTR. ELECTR.	Pompa 2 0,05 l/min Pompa 3 0,05 l/min	250 W	230 V 50 Hz	2 x 5 l	30 kg
3082110002	SD3	ARIA COMPR.* COMPR. AIR*		SANITIZZANTE SANITIZER	ELETTR. ELECTR.	PROD. CERCHI RIM PRODUCT	INOX S. STEEL	Pompa 2 0,05 l/min Pompa 3 0,3 l/min	400W	230 V 50 Hz	2 x 5 l	35 kg
3082410002	SD3	ARIA COMPR.* COMPR. AIR*		PROD. CRUSCOTTO DASHBOARDPOUSH	ELETTR. ELECTR.	PROD. CERCHI RIM PRODUCT	INOX S. STEEL	Pompa 2 0,05 l/min Pompa 3 0,3 l/min	400W	230 V 50 Hz	2 x 5 l	35 kg
3082210001	SD3	ARIA COMPR.* COMPR. AIR*		SANITIZZANTE SANITIZER	ELETTR. ELECTR.	PROD. CRUSCOTTO DASHBOARDPOUSH	ELETTR. ELECTR.	Pompa 2 0,05 l/min Pompa 3 0,05 l/min	250 W	230 V 50 Hz	2 x 5 l	30 kg
3082310002	SD3	ARIA COMPR.* COMPR. AIR*		SANITIZZANTE SANITIZER	ELETTR. ELECTR.	NEROGOMME TIRE BLACKENING	ELETTR. ELECTR.	Pompa 2 0,05 l/min Pompa 3 0,05 l/min	250 W	230 V 50 Hz	2 x 5 l	30 kg
3082610003	SD3	ARIA COMPR.* COMPR. AIR*		PROD. CRUSCOTTO DASHBOARDPOUSH	ELETTR. ELECTR.	NEROGOMME TIRE BLACKENING	ELETTR. ELECTR.	Pompa 2 0,05 l/min Pompa 3 0,05 l/min	250 W	230 V 50 Hz	2 x 5 l	30 kg
3082310001	SD3	ARIA COMPR.* COMPR. AIR*		SANITIZZANTE SANITIZER	ELETTR. ELECTR.	NEROGOMME TIRE BLACKENING	INOX S. STEEL	Pompa 2 0,05 l/min Pompa 3 0,3 l/min	400W	230 V 50 Hz	2 x 5 l	35 kg
3082610002	SD3	ARIA COMPR.* COMPR. AIR*		PROD. CRUSCOTTO DASHBOARDPOUSH	ELETTR. ELECTR.	NEROGOMME TIRE BLACKENING	INOX S. STEEL	Pompa 2 0,05 l/min Pompa 3 0,3 l/min	400W	230 V 50 Hz	2 x 5 l	35 kg
3082510001	SD3	ARIA COMPR.* COMPR. AIR*		NEROGOMME TIRE BLACKENING	ELETTR. ELECTR.	PROD. CERCHI RIM PRODUCT	ELETTR. ELECTR.	Pompa 2 0,05 l/min Pompa 3 0,05 l/min	250 W	230 V 50 Hz	2 x 5 l	30 kg
3082510002	SD3	ARIA COMPR.* COMPR. AIR*		NEROGOMME TIRE BLACKENING	ELETTR. ELECTR.	PROD. CERCHI RIM PRODUCT	INOX S. STEEL	Pompa 2 0,05 l/min Pompa 3 0,3 l/min	400W	230 V 50 Hz	2 x 5 l	35 kg

* SERVIZIO ARIA COMPRESSA SEMPRE FORNITO

* COMPRESSED AIR SERVICE ALWAYS SUPPLIED

CARATTERISTICHE TECNICHE / TECHNICAL FEATURES

ACCESSORI IN DOTAZIONE / SUPPLIED ACCESSORIES

Codice Part No.	Modello Model	Descrizione Description
0875611008*	SD2-SD3	PISTOLA ARIA COMPRESSA CON TUBO 6 m COMPRESSED AIR GUN WITH HOSE 6 m
0875611009*	TUTTI ALL	PISTOLA NEBULIZZATRICE+ TUBO SPIRALATO 6 m SPRAY GUN+ SPIRAL HOSE 6 m
0875611010*	TUTTI ALL	PISTOLA PRODOTTO NEROGOMME+ TUBO SPIRALATO 8 m TIRE BLACKENING PRODUCT GUN+ SPIRAL HOSE 8 m
0875611011*	TUTTI ALL	PISTOLA PRODOTTO CERCHI+ TUBO SPIRALATO 8 m RIM PRODUCT GUN+ SPIRAL HOSE 8 m
0235020005	TUTTI ALL	COPERTURA GETTONIERA COIN ACCEPTOR PROTECTION

* A SECONDA DEL CODICE MACCHINA SCELTO

* DEPENDING ON THE SELECTED MACHINE CODE

ACCESSORI A RICHIESTA / ACCESSORIES ON DEMAND

Codice Part No.	Modello Model	Descrizione Description
0705610002	TUTTI ALL	KIT ISOLAMENTO TERMICO HEAT INSULATION KIT
0445611003	TUTTI ALL	KIT ANTIGELO NO FROST KIT
0495022001	TUTTI ALL	KIT EUROKEY NEXT EUROKEY NEXT KIT
--	TUTTI ALL	ETICHETTA (vedere pag. 179) LABEL (see on pg. 179)

DIMENSIONI
DIMENSIONSIMBALLO (PALLET LEGNO + SCATOLA CARTONE)
PACKAGING (WOOD PALLET + CARTON BOX)SCHEMA DI FISSAGGIO BASAMENTO
INSTALLATION SCHEME

A (mm)	B (mm)	C (mm)	X (mm)	Y (mm)	Z (mm)	D (mm)	E (mm)
420	420	1550	1785	608	500	278	278

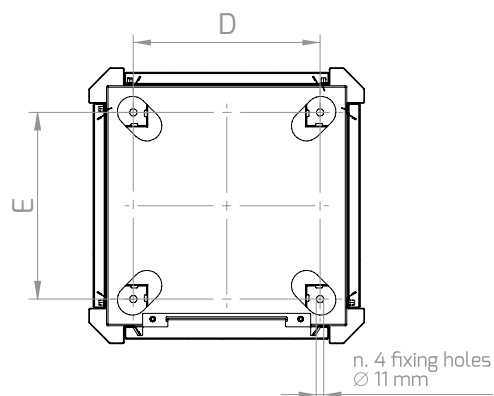
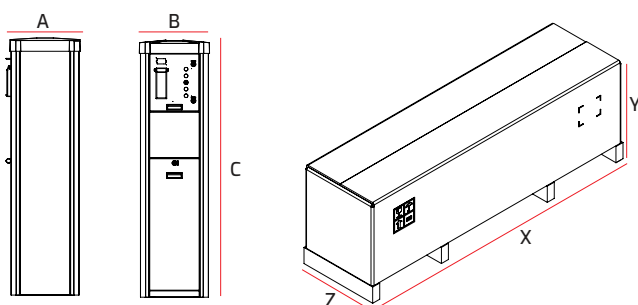



SD1 PARFUME

PROFUMO AUTO / CAR PERFUME DISPENSER

CARATTERISTICHE / FEATURES

- ▲ COLONNINA UNIVERSALE PER EROGAZIONE 4 TIPI DI PROFUMAZIONI CON UNA SOLA PISTOLA EROGATRICE ED UN SOLO TUBO DI MANDATA
- ▲ LA FRAGRANZA SCELTA NON SI MESCOLA CON LA PRECEDENTE SELEZIONATA
- ▲ STRUTTURA PORTANTE MODULARE
- ▲ CHIUSURA A DUE PUNTI ANTIVANDALO
- ▲ CONTENITORE GETTONI LUCCHETTABILE
- ▲ TEMPO CICLO PROGRAMMABILE
- ▲ CALOTTA IN ABS RESISTENTE AI RAGGI UV
- ▲ PANNELLI LATERALI E POSTERIORE DI COPERTURA FACILMENTE RIMOVIBILI PER INTERVENTI DI MANUTENZIONE
- ▲ QUADRO ELETTRICO E GETTONIERA INTEGRATI E DI FACILE ACCESSO
- ▲ PRODOTTI CHIMICI NON FORNITI
- ▲ UNIVERSAL COLUMN DISPENSING 4 DIFFERENT TYPES OF FRAGRANCES USING ONE SINGLE DISPENSING TRIGGER AND ONE DELIVERY HOSE
- ▲ THE SELECTED FRAGRANCE MAY NEVER BE MIXED WITH THE PREVIOUS SELECTION
- ▲ REINFORCED MODULAR FRAME
- ▲ VANDAL-PROOF DOORS AND LOCKS
- ▲ LOCKABLE TOKEN/COIN COMPARTMENT
- ▲ PROGRAMMABLE CYCLE TIME
- ▲ ABS COVER, RESISTANT TO UV RAYS
- ▲ LATERAL AND REAR COVER PANELS ARE EASY TO REMOVE FOR MAINTENANCE OPERATIONS
- ▲ EASY ACCESS INTEGRATED CONTROL BOARD
- ▲ CHEMICAL PRODUCTS NOT INCLUDED



ACCESSORI IN DOTAZIONE / SUPPLIED ACCESSORIES

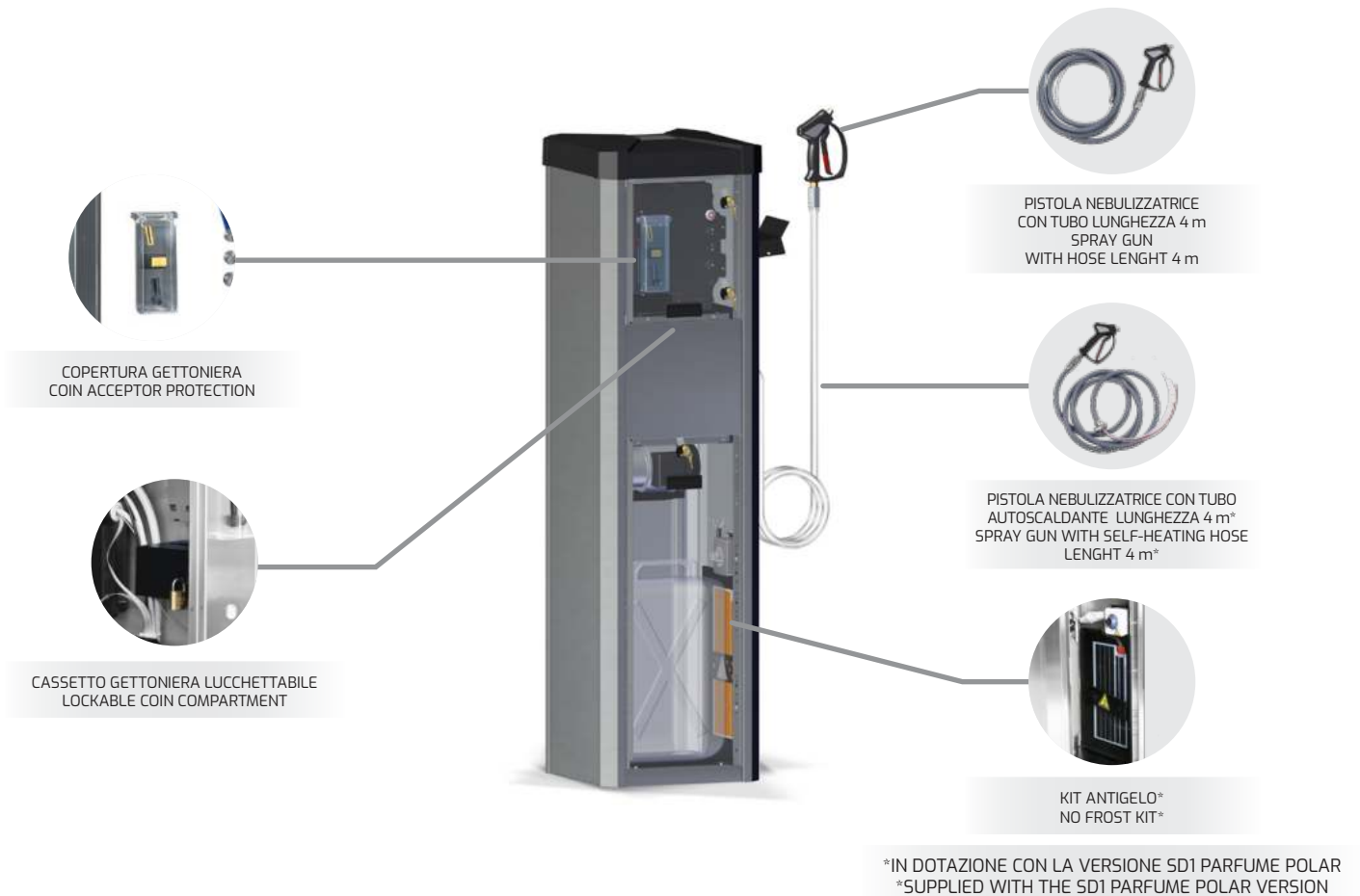

ACCESSORI A RICHIESTA / ACCESSORIES ON DEMAND

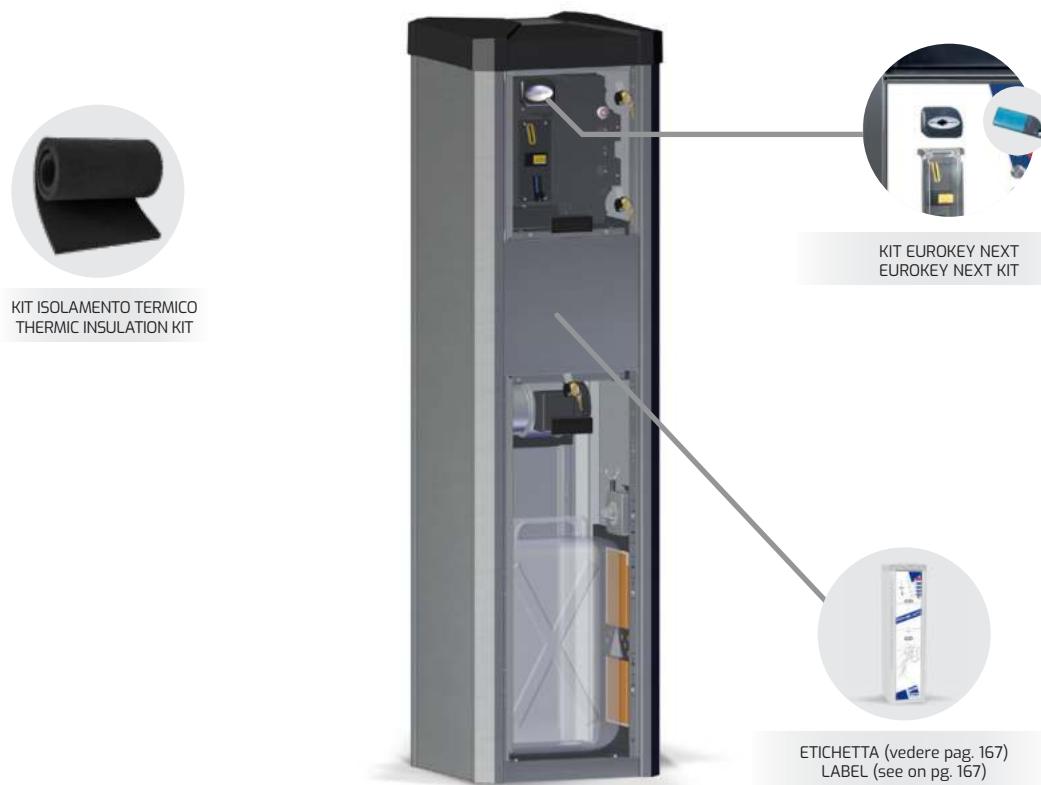

CARATTERISTICHE TECNICHE / TECHNICAL FEATURES

Codice Part No.	Descrizione Description	KitAntigelo No Frost Kit	Pompa Pump	Erogazione Prodotto Product Supply	Potenza Power	Tensione Voltage	Capacità Serbatoio Tank Capacity	Peso Weight
3080510002	SD1 PARFUME		ELETT. ELECTR.	0,05 l/min	300W	230 V - 50 Hz	4x 5 l	35 kg
3080810006	SD1 PARFUME POLAR	✓	ELETT. ELECTR.	0,05 l/min	400W	230 V - 50 Hz	4x 5 l	35 kg

ACCESSORI IN DOTAZIONE / SUPPLIED ACCESSORIES

Codice Part No.	Descrizione Description
0964511006*	PISTOLA NEBULIZZATRICE+TUBO 4 m SPRAY GUN+HOSE 4 m
0964511003*	PISTOLA NEBULIZZATRICE+TUBO 4 m E CAVO AUTOSCALDANTE SPRAY GUN+HOSE 4 m WITH SELF-HEATING WIRE
0445611003*	KIT ANTIGELO NO FROST KIT
0235020005	COPERTURA GETTONIERA COIN ACCEPTOR PROTECTION

ACCESSORI A RICHIESTA / ACCESSORIES ON DEMAND

Codice Part No.	Descrizione Description
0705610002	KIT ISOLAMENTO TERMICO HEAT INSULATION KIT
0495022001	KIT EUROKEY NEXT EUROKEY NEXT KIT
--	ETICHETTA (vedere pag. 179) LABEL (see on pg. 179)

* A SECONDA DEL CODICE MACCHINA SCELTO

* DEPENDING ON THE SELECTED MACHINE CODE

DIMENSIONI
DIMENSIONSIMBALLO (PALLET LEGNO + SCATOLA CARTONE)
PACKAGING (WOOD PALLET + CARTON BOX)SCHEMA DI FISSAGGIO BASAMENTO
INSTALLATION SCHEME

A (mm)	B (mm)	C (mm)	X (mm)	Y (mm)	Z (mm)	D (mm)	E (mm)
420	420	1550	1785	608	500	278	278

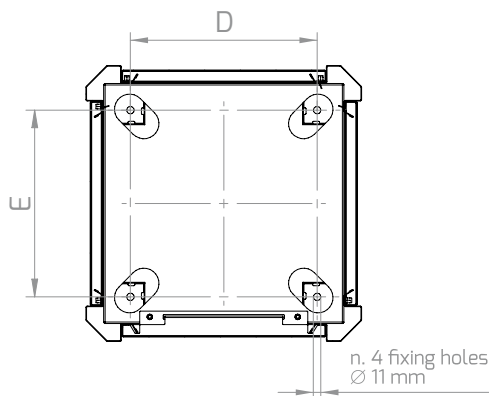
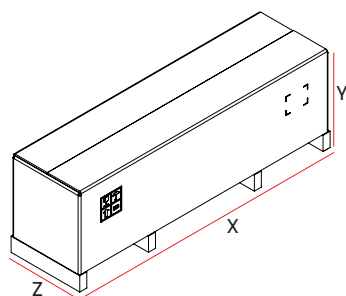
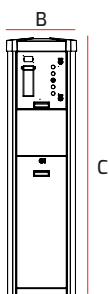
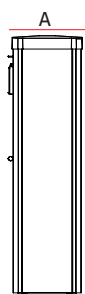

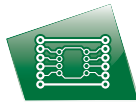

LD2



LD1 - LD2

COLONNINA SINGOLO-DOPPIO PRODOTTO / SINGLE-DOUBLE PRODUCT COLUMN

CARATTERISTICHE / FEATURES

- ❖ COLONNINA UNIVERSALE PER EROGAZIONE 1,2 SERVIZI/PRODOTTI VARI (ARIA COMPRESSA, PROFUMI, SANITIZZANTI, PRODOTTO CRUSCOTTO, ANTIBATTERICO, NEROGOMME)
- ❖ UNIVERSAL COLUMN DISPENSING 1,2 SERVICES/PRODUCTS (COMPRESSED AIR, FRAGRANCES, SANITIZERS, DASHBOARD PRODUCT, ANTIBACTERIAL, TIRE BLACKENING)
- ❖ SODDISFA LE PIÙ SVARIATE NECESSITÀ UTILIZZANDO UNA SOLA MACCHINA A COSTI CONTENUTI
- ❖ SATISFY THE MOST DIVERSE NEED USING ONLY ONE MACHINE AT AFFORDABLE COSTS
- ❖ CHIUSURA A DUE PUNTI ANTIVANDALO
- ❖ VANDAL-PROOF DOORS AND LOCKS
- ❖ TEMPO CICLO PROGRAMMABILE
- ❖ PROGRAMMABLE CYCLE TIME
- ❖ AVVIAMENTO MANUALE A RICHIESTA
- ❖ MANUAL START ON DEMAND
- ❖ CALOTTA IN ABS RESISTENTE AI RAGGI UV
- ❖ ABS COVER, RESISTANT TO UV RAYS
- ❖ PRODOTTI CHIMICI NON FORNITI
- ❖ CHEMICAL PRODUCTS NOT INCLUDED
- ❖ QUADRO ELETTRICO E GETTONIERA INTEGRATI E DI FACILE ACCESSO
- ❖ EASY ACCESS INTEGRATED CONTROL BOARD
- ❖ SPORTELLI ANTERIORI E POSTERIORI FACILMENTE RIMOVIBILI PER INTERVENTI DI MANUTENZIONE
- ❖ FRONT AND REAR COVER PANELS EASY TO REMOVE FOR MAINTENANCE OPERATIONS



ACCESSORI IN DOTAZIONE / SUPPLIED ACCESSORIES

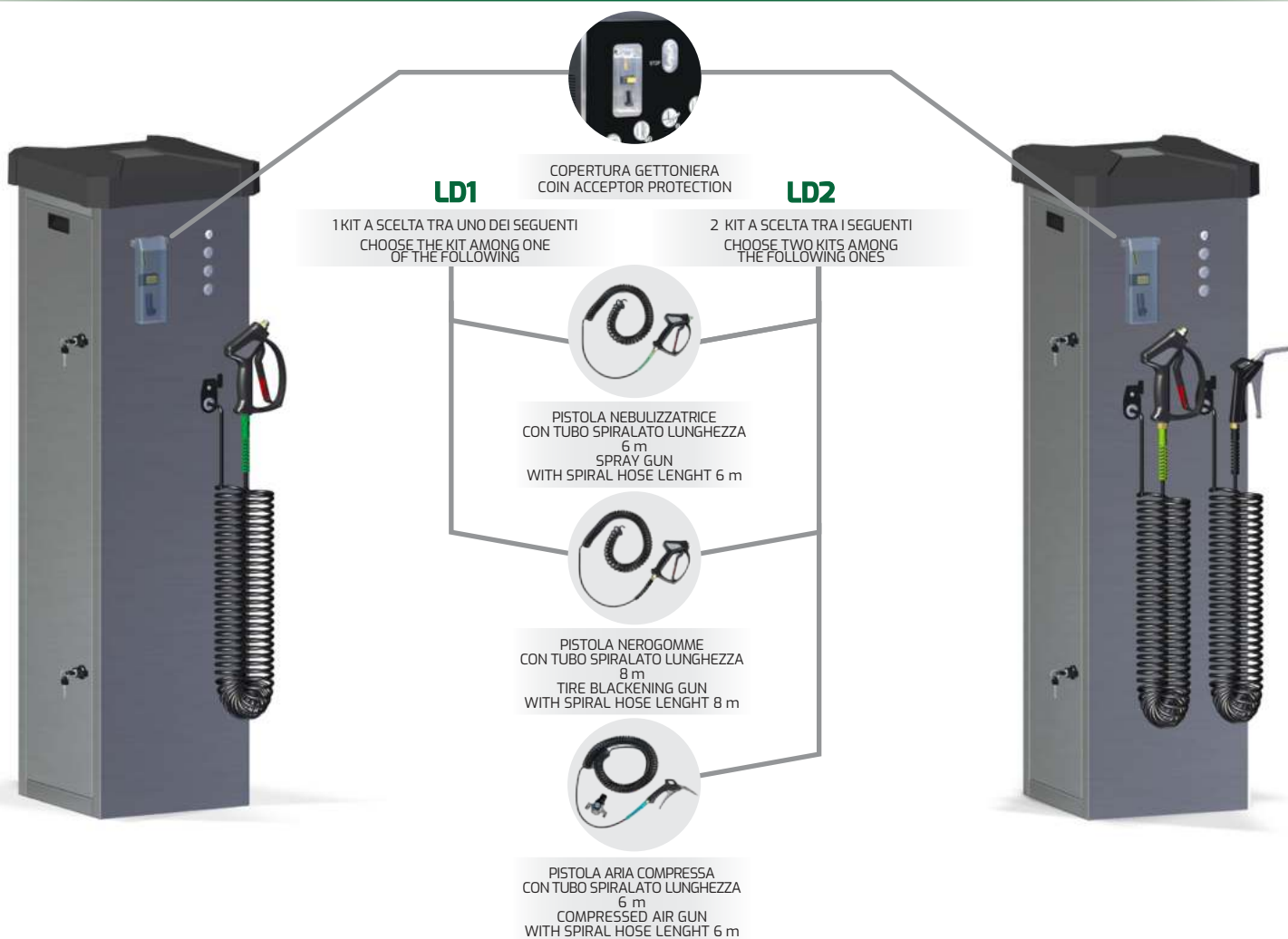

ACCESSORI A RICHIESTA / ACCESSORIES ON DEMAND

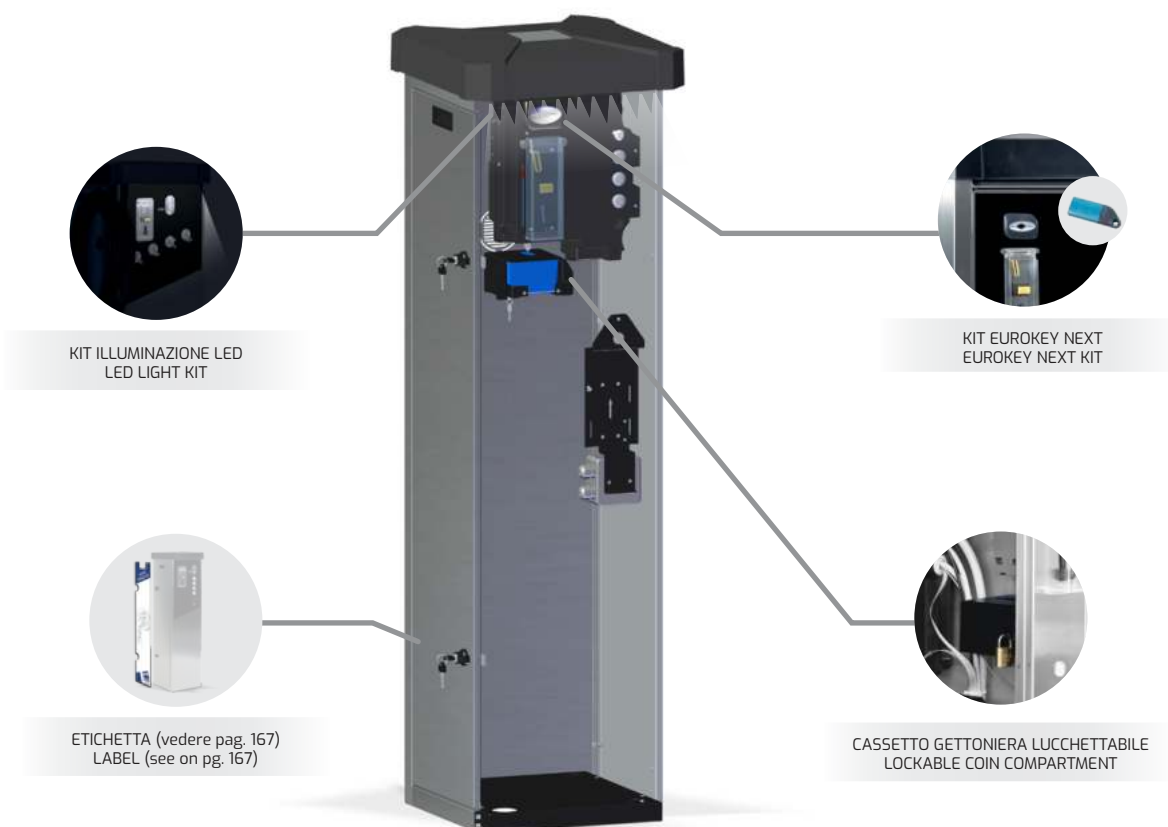

CARATTERISTICHE TECNICHE / TECHNICAL FEATURES

Codice Part No.	Modello Model	Prodotto 1 Product 1	Pompa 1 Pump 1	Prodotto 2 Product 2	Pompa 2 Pump 2	Erogazione Prodotto Product Supply	Potenza Power	Tensione Voltage	Cap. Serbatoio Tank Capacity	Peso Tot. Weight
3084510001	LD1	SANITIZZANTE SANITIZER	ELETTR. ELECTR.	--	--	0,05 l/min	100W	230 V 50 Hz	5 l	30 kg
3084510002	LD1	NEROGOMME TIRE BLACK- ENING	ELETTR. ELECTR.	--	--	0,05 l/min	100W	230 V 50 Hz	5 l	30 kg
3084610001	LD2	ARIA COMPR. COMPR. AIR	--	SANITIZZANTE SANITIZER	ELETTR. ELECTR.	0,05 l/min	100W	230 V 50 Hz	5 l	35 kg
3084710001	LD2	ARIA COMPR. COMPR. AIR	--	NEROGOMME TIREBLACKENING	ELETTR. ELECTR.	0,05 l/min	100W	230 V 50 Hz	5 l	35 kg
3084810001	LD2	NEROGOMME TIREBLACKENING	ELETTR. ELECTR.	SANITIZZANTE SANITIZER	ELETTR. ELECTR.	Pompa 1 0,05 l/min Pompa 2 0,05 l/min	200W	230 V 50 Hz	2 x 5 l	35 kg

ACCESSORI IN DOTAZIONE / SUPPLIED ACCESSORIES

Codice Part No.	Modello Model	Descrizione Description
0875611008*	LD2	PISTOLA ARIA COMPRESSA CON TUBO 6 m COMPRESSED AIR GUN WITH HOSE 6 m
0875611009*	TUTTI ALL	PISTOLA NEBULIZZATRICE+ TUBO SPIRALATO 6 m SPRAY GUN+SPIRAL HOSE 6 m
0875611010*	TUTTI ALL	PISTOLA PRODOTTO NEROGOMME+ TUBO SPIRALATO 8 m TIRE BLACKENING PRODUCT GUN+ SPIRAL HOSE 8 m
0235020005	TUTTI ALL	COPERTURA GETTONIERA COIN ACCEPTOR PROTECTION

* A SECONDA DEL CODICE MACCHINA SCELTO
* DEPENDING ON THE SELECTED MACHINE CODE

ACCESSORI A RICHIESTA / ACCESSORIES ON DEMAND

Codice Part No.	Modello Model	Descrizione Description
0495022001	TUTTI ALL	KIT EUROKEY NEXT EUROKEY NEXT KIT
0170242011	TUTTI ALL	CASSETTO GETTONIERA LUCCHETTABILE LOCKABLE COIN COMPARTMENT
0445611036	TUTTI ALL	KIT ILLUMINAZIONE LED LED LIGHT KIT
--	TUTTI ALL	ETICHETTA (vedere pag. 179) LABEL (see on pg. 179)

DIMENSIONI
DIMENSIONSIMBALLO (SCATOLA CARTONE)
PACKAGING (CARTON BOX)SCHEMA DI FISSAGGIO BASAMENTO
INSTALLATION SCHEME

A (mm)	B (mm)	C (mm)	X (mm)	Y (mm)	Z (mm)	D (mm)	E (mm)
420	420	1410	1500	600	470	250	300

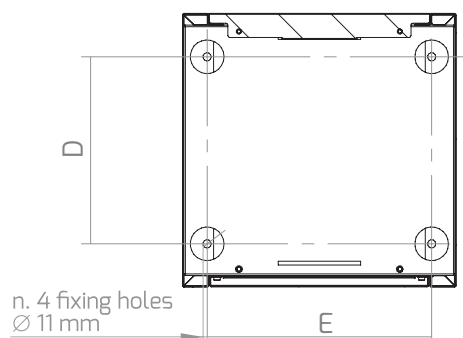
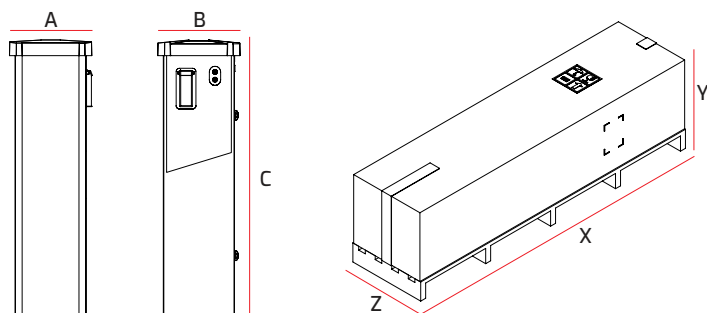



LD1 SANISPRAY

EROGATORE DI PRODOTTO SANITIZZANTE NEBULIZZATO / DISPENSER OF NEBULIZED SANITIZING PRODUCT

CARATTERISTICHE / FEATURES

- COLONNINA UNIVERSALE PER EROGAZIONE SANITIZZANTE NEBULIZZATO ANTIBATTERICO
- UNIVERSAL COLUMN DISPENSING ANTIBACTERIAL NEBULIZED SANITIZING PRODUCT
- CHIUSURA A DUE PUNTI ANTIVANDALO
- VANDAL-PROOF DOORS AND LOCKS
- TEMPO CICLO PROGRAMMABILE
- PROGRAMMABLE CYCLE TIME
- AVVIAMENTO MANUALE A RICHIESTA
- MANUAL START ON DEMAND
- CALOTTA IN ABS RESISTENTE AI RAGGI UV
- ABS COVER, RESISTANT TO UV RAYS
- PRODOTTI CHIMICI NON FORNITI
- CHEMICAL PRODUCTS NOT INCLUDED
- QUADRO ELETTRICO E GETTONIERA INTEGRATI E DI FACILE ACCESSO
- EASY ACCESS INTEGRATED CONTROL BOARD
- SPORTELLI ANTERIORI E POSTERIORI FACILMENTE RIMOVIBILI PER INTERVENTI DI MANUTENZIONE
- FRONT AND REAR COVER PANELS EASY TO REMOVE FOR MAINTENANCE OPERATIONS



ACCESSORI IN DOTAZIONE / SUPPLIED ACCESSORIES



ACCESSORI A RICHIESTA / ACCESSORIES ON DEMAND



CARATTERISTICHE TECNICHE / TECHNICAL FEATURES

Codice Part No.	Prodotto Product	Erogazione Prodotto Product Supply	Potenza Power	Tensione Voltage	Cap. Serbatoio Tank Capacity	Tubo spiralato Hose
3084510003 *	SANISPRAY STANDARD STANDARD SANISPRAY	0,04 l/min	50W	230 V - 50 Hz	11 l	12 m
3084510006	SANISPRAY con COMPRESSORE SANISPRAY with COMPRESSOR	0,04 l/min	400W	230 V - 50 Hz	11 l	12 m

*NECESSITA DI COLLEGAMENTO A RETE PNEUMATICA (PRESSIONE MIN. 2 bar)

*REQUIRES A PNEUMATIC NETWORK CONNECTION (MIN. PRESSURE 2 bar)

ACCESSORI IN DOTAZIONE / SUPPLIED ACCESSORIES

Codice Part No.	Descrizione Description
0875611012	PISTOLA SANISPRAY+TUBO SPIRALATO 12 m SANISPRAY GUN+ SPIRAL HOSE 12 m
0235020005	COPERTURA GETTONIERA COIN ACCEPTOR PROTECTION

ACCESSORI A RICHIESTA / ACCESSORIES ON DEMAND

Codice Part No.	Descrizione Description
0495022001	KIT EUROKEY NEXT EUROKEY NEXT KIT
0170242011	CASSETTO GETTONIERA LUCCHETTABILE LOCKABLE COIN COMPARTMENT
0445611036	KIT ILLUMINAZIONE LED LED LIGHT KIT
0445611050	KIT DISPLAY DISPLAY KIT
--	ETICHETTA (vedere pag. 179) LABEL (see on pg. 179)

DIMENSIONI
DIMENSIONSIMBALLO (SCATOLA CARTONE)
PACKAGING (CARTON BOX)SCHEMA DI FISSAGGIO BASAMENTO
INSTALLATION SCHEME

A (mm)	B (mm)	C (mm)	X (mm)	Y (mm)	Z (mm)	D (mm)	E (mm)
420	420	1410	1500	600	470	250	300

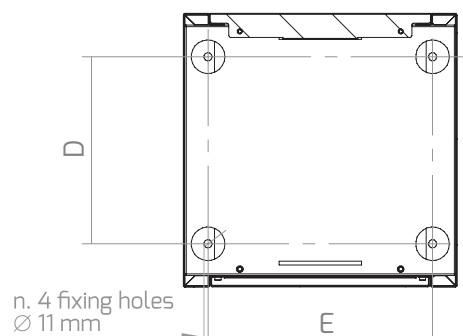
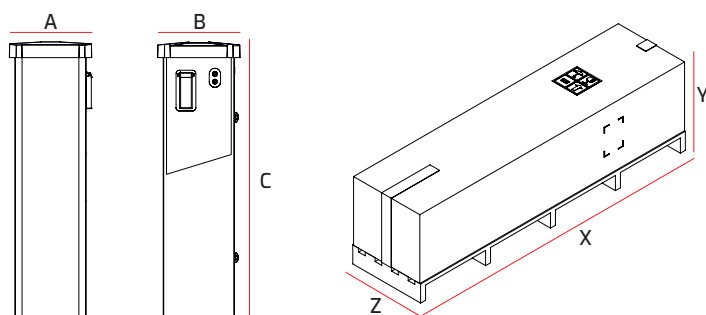

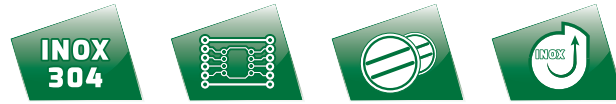

WLD

DISTRIBUTORE LIQUIDO LAVAVETRI / WINDSCREEN WIPER LIQUID DISPENSER

CARATTERISTICHE / FEATURES

- CHIUSURA A DUE PUNTI ANTIVANDALO
 - QUADRO ELETTRICO E GETTONIERA INTEGRATI
 - CALOTTA IN ABS RESISTENTE AI RAGGI UV
 - EROGAZIONE LIQUIDO PROGRAMMABILE (0,5 l, 1 l, 1,5 l, 2 l, 2,5 l, 3 l)
 - INDICATORE ESTERNO DI LIVELLO LIQUIDO LAVAVETRI
 - TAPPO CHIUSURA SERBATOIO LIQUIDO CON LUCCHETTO ACCESSIBILE DALL'ESTERNO
 - SERBATOIO LIQUIDO INTEGRATO (CAPACITÀ 100 l)
 - PRODOTTO CHIMICO NON FORNITO
 - SPORTELLI ANTERIORI E POSTERIORI FACILMENTE RIMOVIBILI PER INTERVENTI DI MANUTENZIONE

 - VANDAL-PROOF DOORS AND LOCKS
 - INTEGRATED CONTROL BOARD
 - ABS COVER, RESISTANT TO UV RAYS
 - PROGRAMMABLE LIQUID QUANTITY (0,5 l, 1 l, 1,5 l, 2 l, 2,5 l, 3 l)
 - EXTERNAL WINDSCREEN WIPER LEVEL GAUGE
 - LOCKABLE LIQUID TANK CAP EXTERNALLY ACCESSIBLE
 - INTEGRATED LIQUID TANK (CAPACITY 100 l)
 - CHEMICAL PRODUCT NOT INCLUDED
 - FRONT AND REAR COVER PANELS EASY TO REMOVE FOR MAINTENANCE OPERATIONS



ACCESSORI IN DOTAZIONE / SUPPLIED ACCESSORIES



COPERTURA GETTONIERA
COIN ACCEPTOR PROTECTION



PISTOLA EROGATRICE
CON TUBO SPIRALATO LUNGHEZZA 6 m
DISPENSING GUN
WITH SPIRAL HOSE LENGHT 6 m

ACCESSORI A RICHIESTA / ACCESSORIES ON DEMAND

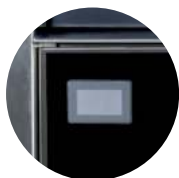

DISPLAY



KIT EUROKEY NEXT
EUROKEY NEXT KIT



KIT ILLUMINAZIONE LED
LED LIGHT KIT



ETICHETTA (vedere pag. 167)
LABEL (see on pg. 167)

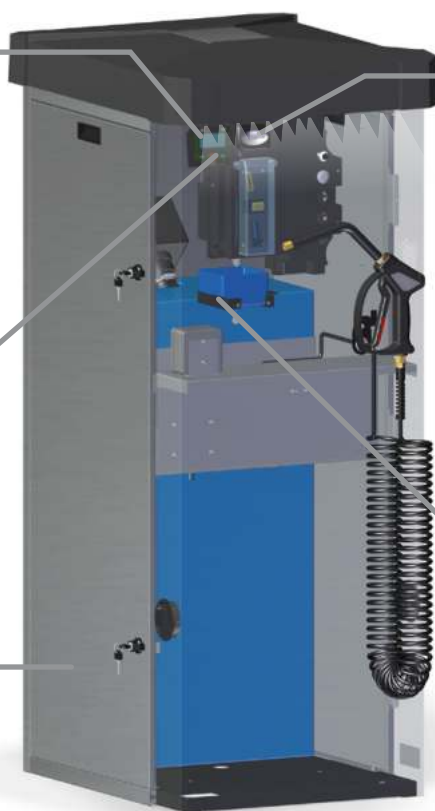

CASSETTO GETTONIERA LUCCHETTABILE
LOCKABLE COIN COMPARTMENT

CARATTERISTICHE TECNICHE / TECHNICAL FEATURES

Codice Part No.	Potenza Power	Erogazione Prodotto Product Supply	Capacità Serbatoio Tank Capacity	Alimentazione Power Supply	Peso Weight
3084910001	150W	2,4 l/min	100 l	230 V - 50 Hz	80 kg

ACCESSORI IN DOTAZIONE / SUPPLIED ACCESSORIES

Codice Part No.	Descrizione Description
0875611013	PISTOLA EROGATRICE CON TUBO SPIRALATO LUNGHEZZA 6 m DISPENSING GUN WITH SPIRAL HOSE LENGHT 6 m
0235020005	COPERTURA GETTONIERA COIN ACCEPTOR PROTECTION

ACCESSORI A RICHIESTA / ACCESSORIES ON DEMAND

Codice Part No.	Descrizione Description
0495022001	KIT EUROKEY NEXT EUROKEY NEXT KIT
0170242011	CASSETTO GETTONIERA LUCCHETTABILE LOCKABLE COIN COMPARTMENT
0445611047	KIT ILLUMINAZIONE LED LED LIGHT KIT
0445611050	DISPLAY
--	ETICHETTA (vedere pag. 179) LABEL (see on pg. 179)

DIMENSIONI
DIMENSIONSIMBALLO (PALLET LEGNO + PLURIBALL)
PACKAGING (WOOD PALLET + PLURIBALL)SCHEMA DI FISSAGGIO BASAMENTO
INSTALLATION SCHEME

A (mm)	B (mm)	C (mm)	X (mm)	Y (mm)	Z (mm)	D (mm)	E (mm)
592	714	1198	900	1578	800	453	600

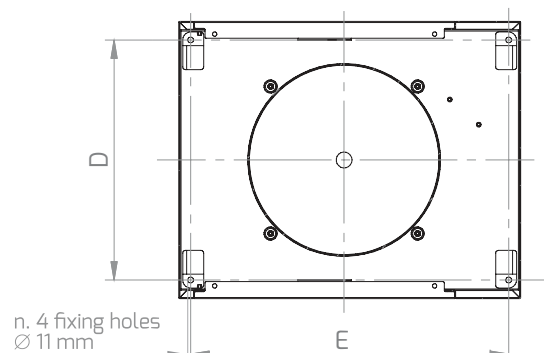
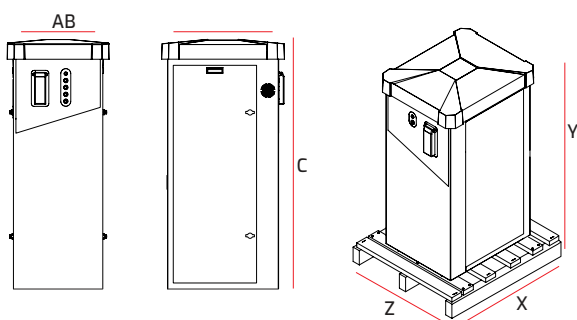





07 MODULI MULTIFUNZIONE PER LAVAGGIO MULTIFUNCTIONAL WASH MODULES

01	SPW WASH HP&FOAM HP MODULO PRELAVAGGIO E SCHIUMA IN ALTA PRESSIONE HIGH PRESSURE FOAM PRE-WASH MODULE	135
02	SPW WASH HP&FOAM LP MODULO PRELAVAGGIO CON SPAZZOLA SCHIUMA IN BASSA PRESSIONE LOW PRESSURE FOAM BRUSH PRE-WASH MODULE	139
03	SPW WASH HP MODULO PRELAVAGGIO IN ALTA PRESSIONE · HIGH PRESSURE PRE-WASH MODULE	143
04	SFT MODULO PRELAVAGGIO SCHIUMA ALTA PRESSIONE · SELF HIGH PRESSURE FOAM TOWER	147
05	ABW COLONNINA ASCIUGA AUTO/MOTO · CAR/MOTORCYCLE DRYING COLUMN	151
06	MBW COLONNINA MULTIFUNZIONE PER LAVAGGIO MOTOCICLI · MULTIFUNCTION COLUMN FOR MOTORCYCLE CLEANING	155
07	BKW COLONNINA MULTIFUNZIONE PER LAVAGGIO BICICLETTE · MULTIFUNCTION COLUMN FOR BICYCLE WASHING	159

L'**ACCIAIO INOX** che utilizziamo per le nostre macchine è del tipo AISI 304 quindi a basso contenuto di carbonio.

I principali vantaggi di questo materiale per le nostre applicazioni sono :

- Elevata resistenza alle intemperie e corrosione
- Facilità di ripulitura e ottimo coefficiente igienico.

*The **STAINLESS STEEL** used in the construction of our machines is of the type AISI 304 with low carbon content.*

The main advantages of this material for our applications are:

- *High level of resistance to extreme weather and corrosion*
- *Ease of cleaning and maintenance and excellent hygiene properties.*

SCHEDA ELETTRONICA, dotata di temporizzatore elettronico, svolge una o più azioni a intervalli di tempo prefissati, facilmente regolabile secondo le esigenze del cliente.

*The **ELECTRONIC CIRCUIT BOARD**, supplied with an electronic timer, manages one or more functions at prefixed intervals, and is easily adjustable according to the client's needs.*

La **GETTONIERA ELETTRONICA**, offerta di serie, combina una straordinaria selettività ad un'estrema versatilità di programmazione.

*The **ELECTRONIC TOKEN AND COIN-OP** mechanism, supplied as standard equipment, combines extraordinary versatility with extreme programming flexibility.*

La **TURBINA** per l'asciugatura e l'eliminazione delle gocce garantisce una elevata affidabilità e durata nel tempo oltreché elevata silenziosità di funzionamento, assenza di vibrazioni e non ultimo assenza di manutenzione.

*The **TURBINE** for drying and eliminating drop guarantees a high level of reliability and durability over time as well as low-noise functioning, lack of vibrations and last but not least is completely maintenance-free.*

Il **MANOMETRO ANALOGICO** certificato, combina economicità a praticità e facilità d'uso.

*The certified **ANALOGICAL PRESSURE GAUGE**, combines economic advantages, practicality and ease of use.*

Il **LAVAGGIO ALTA PRESSIONE** grazie alla pompa alta pressione (100 bar - 13 l/m) con giunto elastico.

*The **HIGH PRESSURE WASH**, thanks to the high pressure pump (100 bar - 13 l/m) with elastic flexible joint.*

Il **LAVAGGIO BASSA PRESSIONE** (3 bar).

*The **LOW PRESSURE WASH**, (3 bar) .*

La **SCHIUMA IN ALTA PRESSIONE** grazie alla pompa alta pressione dedicata.

*The **HIGH PRESSURE FOAM**, thanks to the dedicated high pressure pump*

La **SCHIUMA IN BASSA PRESSIONE** grazie alla spazzola dedicata.

*The **LOW PRESSURE FOAM**, thanks to the dedicated brush .*

	SPW WASH HP	SPW WASH HP & FOAM LP	SPW WASH HP & FOAM HP	SFT	ABW	BKW
L'ACCIAIO INOX	✓	✓	✓	✓	✓	✓
SCHEDA ELETTRONICA	✓	✓	✓	✓	✓	✓
GETTONIERA ELETTRONICA	✓	✓	✓	✓	✓	✓
TURBINA					✓	✓
MANOMETRO ANALOGICO						✓
LAVAGGIO ALTA PRESSIONE	✓	✓	✓			
LAVAGGIO BASSA PRESSIONE						✓
SCHIUMA IN ALTA PRESSIONE			✓	✓		
SCHIUMA IN BASSA PRESSIONE		✓				✓



SPW-WASH HP&FOAM HP

MODULO PRELAVAGGIO E SCHIUMA IN ALTA PRESSIONE / HIGH PRESSURE FOAM PRE-WASH MODULE

CARATTERISTICHE / FEATURES

- ▶ MODULO SELF-SERVICE DEDICATO AL PRELAVAGGIO CON EROGAZIONE DI ACQUA E SCHIUMA IN ALTA PRESSIONE, ADATTO A TUTTI I MEZZI DI TRASPORTO
 - ▶ STRUTTURA IN ACCIAIO INOX AISI 304
 - ▶ POMPA ALTA PRESSIONE (100 bar - 13 l/m) CON GIUNTO ELASTICO
 - ▶ CHIUSURA A DUE PUNTI ANTIVANDALO
 - ▶ CALOTTA IN ABS RESISTENTE AI RAGGI UV
 - ▶ QUADRO ELETTRICO E GETTONIERA INTEGRATI DI FACILE ACCESSO
 - ▶ TEMPO CICLO PROGRAMMABILE
 - ▶ POMPA PER SCHIUMA ALTA PRESSIONE
 - ▶ POMPA DOSATRICE

 - ▶ SELF-SERVICE MODULE DEDICATE TO HIGH PRESSURE WATER AND FOAM PRE-WASH, SUITABLE FOR ALL MEANS OF TRANSPORT
 - ▶ AISI 304 STAINLESS STEEL CABINET
 - ▶ HIGH PRESSURE PUMP (100 bar - 13 l/m) WITH ELASTIC FLEXIBLE JOINT
 - ▶ VANDAL-PROOF DOORS AND LOCKS
 - ▶ ABS COVER, RESISTANT TO UV RAYS
 - ▶ EASY ACCESS INTEGRATED CONTROL BOARD
 - ▶ PROGRAMMABLE CYCLE TIME
 - ▶ HIGH PRESSURE FOAM PUMP
 - ▶ DOSING PUMP



ACCESSORI A RICHIESTA / ACCESSORIES ON DEMAND

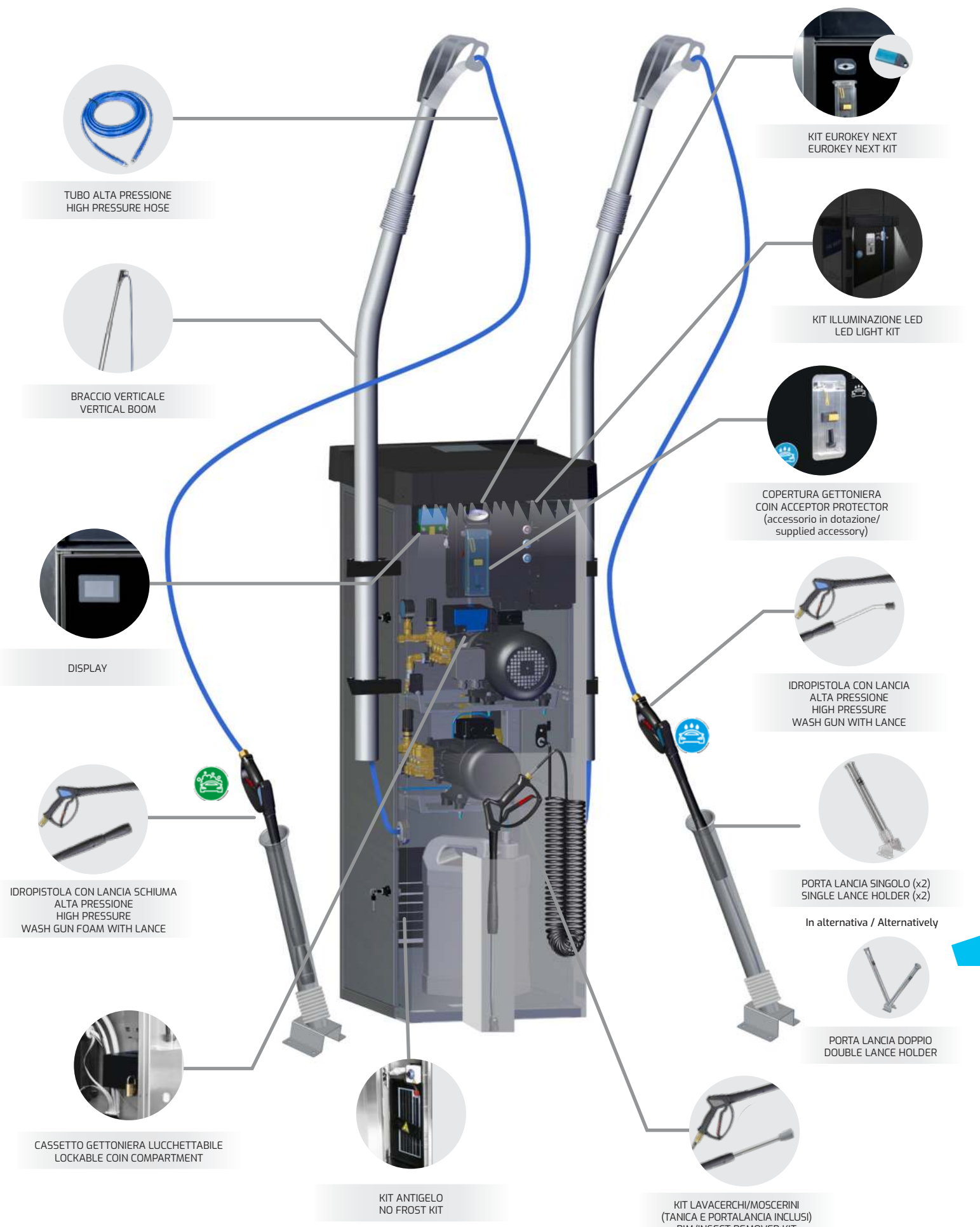

TUBO ALTA PRESSIONE
HIGH PRESSURE HOSE



BRACCIO VERTICALE
VERTICAL BOOM



DISPLAY



IDROPISTOLA CON LANCIA
ALTA PRESSIONE
HIGH PRESSURE
WASH GUN FOAM WITH LANCE



CASSETTO GETTONIERA LUCCHETTABILE
LOCKABLE COIN COMPARTMENT



KIT ANTIGELO
NO FROST KIT



KIT EUROKEY NEXT
EUROKEY NEXT KIT



KIT ILLUMINAZIONE LED
LED LIGHT KIT



COPERTURA GETTONIERA
COIN ACCEPTOR PROTECTOR
(accessorio in dotazione/
supplied accessory)



IDROPISTOLA CON LANCIA
ALTA PRESSIONE
HIGH PRESSURE
WASH GUN WITH LANCE



PORTA LANCIA SINGOLO (x2)
SINGLE LANCE HOLDER (x2)

In alternativa / Alternatively



PORTA LANCIA DOPPIO
DOUBLE LANCE HOLDER



KIT LAVACERCHI/MOSCHERINI
(TANICA E PORTALANCIA INCLUSI)
RIM/INSECT REMOVER KIT
(TANK AND LANCE HOLDER INCLUDED)



ACQUA IN ALTA PRESSIONE
HIGH PRESSURE WATER



SCHIUMA IN ALTA PRESSIONE
HIGH PRESSURE FOAM

CARATTERISTICHE TECNICHE / TECHNICAL FEATURES

Codice Part No.	Acqua Alta Pressione High Pressure Water Program	Schiuma Alta Pressione High Pressure Foam Program	Spazzola Bassa Pressione Low Pressure Brush Program	Tensione Voltage	Potenza Power	Peso Totale Total Weight
3040120004	✓	✓		400 V - 50 Hz R-S-T+N	4200 W	145 kg

ACCESSORI IN DOTAZIONE / SUPPLIED ACCESSORIES

Codice Part No.	Descrizione Description
0235020005	COPERTURA GETTONIERA COIN ACCEPTOR PROTECTION

ACCESSORI A RICHIESTA / ACCESSORIES ON DEMAND

Codice Part No.	Descrizione Description	Codice Part No.	Descrizione Description
0445611050	KIT DISPLAY DISPLAY KIT	1031120400	IDROPISTOLA SG31 GIREVOLE G3/8 F CON LANCIA EX28 RND SL - UGELLO 055 25° WASH GUN SG31 SWIVEL G3/8 F WITH LANCE EX28 RND SL - NOZZLE 055 25°
0495022001	KIT EUROKEY NEXT EUROKEY NEXT KIT	1031120600*	IDROPISTOLA SG31 GIREVOLE G3/8 F PERDENTE 1,1 CON LANCIA EX28 RND SL - UGELLO 055 25° WASH GUN SG31 SWIVEL G3/8 F WEEP 1,1 WITH LANCE EX28 RND SL - NOZZLE 055 25°
0170242011	CASSETTO GETTONIERA LUCCHETTABILE LOCKABLE COIN COMPARTMENT	1031120700*	IDROPISTOLA SG31 GIREVOLE G3/8 F PERDENTE 1,8 CON LANCIA EX28 RND SL - UGELLO 055 25° WASH GUN SG31 SWIVEL G3/8 F WEEP 1,8 WITH LANCE EX28 RND SL - NOZZLE 055 25°
0445611047	AVVIAMENTO MANUALE MANUAL START	1031120185	IDROPISTOLA SG31 GIREVOLE G3/8 F CON PROLUNGA EX28 RND SL - FH35 UGELLO 040 WASH GUN SG31 SWIVEL G3/8 F WITH EXTENSION EX28 RND SL - FH35 NOZZLE 040
0445611065	KIT ILLUMINAZIONE LED LED LIGHT KIT	1031120385*	IDROPISTOLA SG31 GIREVOLE G3/8 F PERDENTE 1,1 CON PROLUNGA EX28 RND SL - FH35 UGELLO 040 WASH GUN SG31 SWIVEL G3/8 F WITH EXTENSION EX28 RND SL - FH35 NOZZLE 040
0445611096	KIT LAVACERCHI / MOSCERINI RIM / INSECT REMOVER KIT	1031120485*	IDROPISTOLA SG31 GIREVOLE G3/8 F PERDENTE 1,8 CON PROLUNGA EX28 RND SL - FH35 UGELLO 040 WASH GUN SG31 SWIVEL G3/8 F WEEP 1,8 WITH EXTENSION EX28 RND SL - FH35 NOZZLE 040
1225020200	BRACCIO VERTICALE (l= 300 mm) VERTICAL BOOM (l= 300 mm)	--	ETICHETTA (vedere pag. 179) LABEL (see on pag. 179)
1225020300	BRACCIO VERTICALE (l= 200 mm) VERTICAL BOOM (l= 200 mm)		
1231000100	PORTA LANCIA SINGOLO SINGLE LANCE HOLDER		
1230020100	PORTA LANCIA DOPPIO DOUBLE LANCE HOLDER		
0964020012	TUBO ALTA PRESSIONE R1 1/4"-3/8" BSP M BLUE R1 1/4"-3/8" BSP M BLUE HIGH PRESSURE HOSE		

* A SECONDA DEL VOLUME DI PERDITA ACQUA DESIDERATO
ACCORDING THE REQUIRED LEAKAGE

DIMENSIONI
DIMENSIONSIMBALLO (SCATOLA CARTONE)
PACKAGING (CARTON BOX)SCHEMA DI FISSAGGIO BASAMENTO
INSTALLATION SCHEME

A (mm)	B (mm)	C (mm)	X (mm)	Y (mm)	Z (mm)	D (mm)	E (mm)
592	714	1570	900	1700	800	453	600

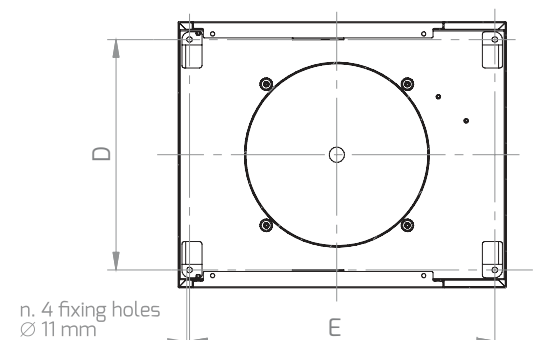
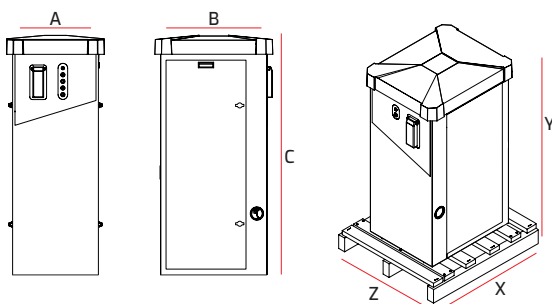



SPW-WASH HP&BRUSH FOAM LP

MODULO PRELAVAGGIO CON SPAZZOLA SCHIUMA IN BASSA PRESSIONE / LOW PRESSURE FOAM BRUSH PRE-WASH MODULE

CARATTERISTICHE / FEATURES

- ▲ MODULO SELF-SERVICE DEDICATO AL PRELAVAGGIO CON EROGAZIONE DI ACQUA IN ALTA PRESSIONE E SPAZZOLA IN BASSA PRESSIONE, ADATTO A TUTTI I MEZZI DI TRASPORTO
 - ▲ STRUTTURA IN ACCIAIO INOX AISI 304
 - ▲ POMPA ALTA PRESSIONE (100 bar - 13 l/m) CON GIUNTO ELASTICO
 - ▲ CHIUSURA A DUE PUNTI ANTIVANDALO
 - ▲ CALOTTA IN ABS RESISTENTE AI RAGGI UV
 - ▲ QUADRO ELETTRICO E GETTONIERA INTEGRATI DI FACILE ACCESSO
 - ▲ TEMPO CICLO PROGRAMMABILE

 - ▲ SELF-SERVICE MODULE DEDICATE TO HIGH PRESSURE WATER AND LOW PRESSURE FOAM PRE-WASH, SUITABLE FOR ALL MEANS OF TRANSPORT
 - ▲ AISI 304 STAINLESS STEEL CABINET
 - ▲ HIGH PRESSURE PUMP (100 bar - 13 l/m) WITH ELASTIC FLEXIBLE JOINT
 - ▲ VANDAL-PROOF DOORS AND LOCKS
 - ▲ ABS COVER, RESISTANT TO UV RAYS
 - ▲ EASY ACCESS INTEGRATED CONTROL BOARD
 - ▲ PROGRAMMABLE CYCLE TIME



ACCESSORI A RICHIESTA / ACCESSORIES ON DEMAND

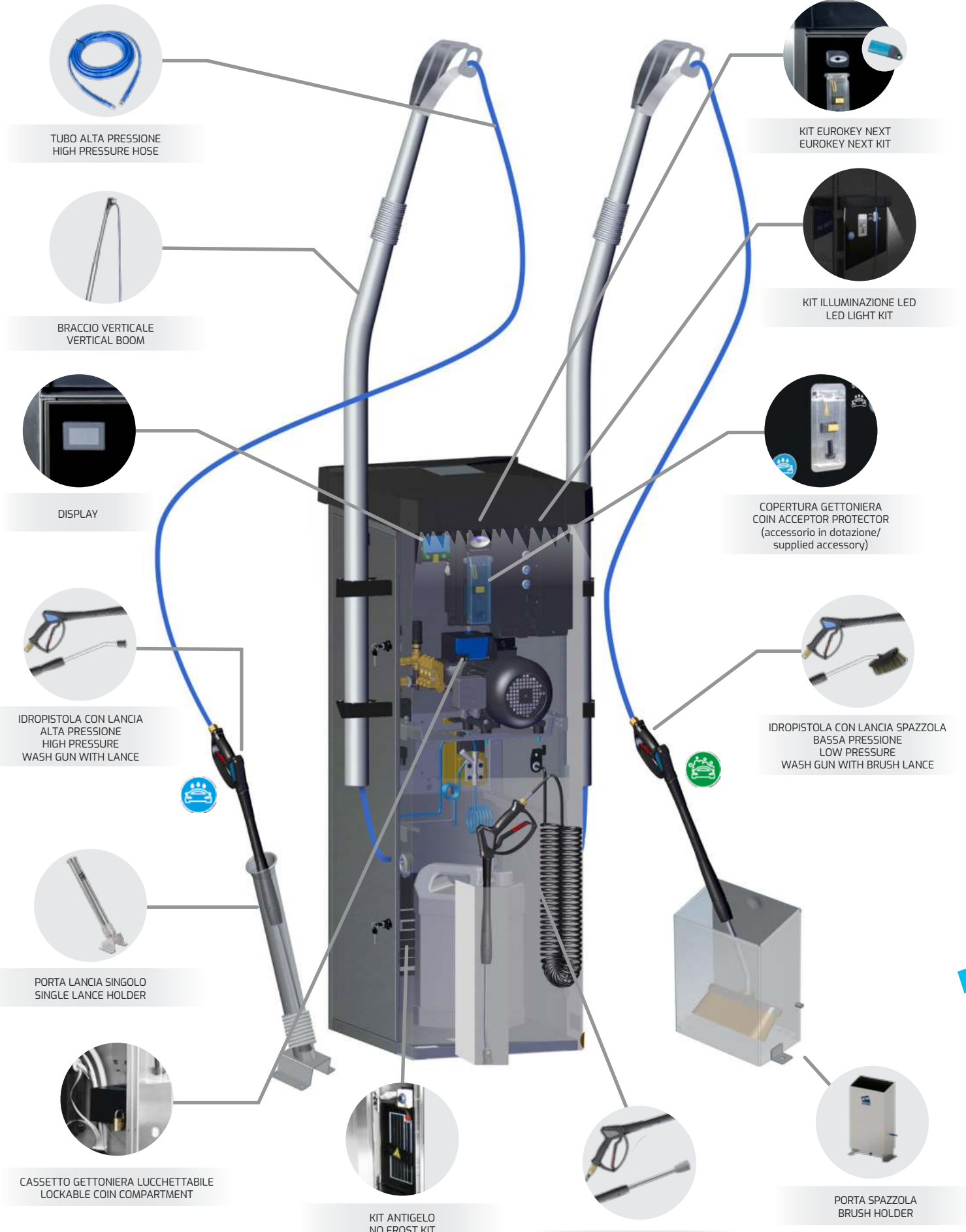

TUBO ALTA PRESSIONE
HIGH PRESSURE HOSE



BRACCIO VERTICALE
VERTICAL BOOM



DISPLAY



IDROPISTOLA CON LANCIA
ALTA PRESSIONE
HIGH PRESSURE
WASH GUN WITH LANCE



PORTA LANCIA SINGOLO
SINGLE LANCE HOLDER



CASSETTO GETTONIERA LUCCHETTABILE
LOCKABLE COIN COMPARTMENT



KIT ANTIGELO
NO FROST KIT



KIT EUROKEY NEXT
EUROKEY NEXT KIT



KIT ILLUMINAZIONE LED
LED LIGHT KIT



COPERTURA GETTONIERA
COIN ACCEPTOR PROTECTOR
(accessorio in dotazione/
supplied accessory)



IDROPISTOLA CON LANCIA SPAZZOLA
BASSA PRESSIONE
LOW PRESSURE
WASH GUN WITH BRUSH LANCE



KIT LAVACERCHI/MOSKERINI
(TANICA E PORTALANCIA INCLUSI)
RIM/INSECT REMOVER KIT
(TANK AND LANCE HOLDER INCLUDED)



PORTA SPAZZOLA
BRUSH HOLDER



ACQUA IN ALTA PRESSIONE
HIGH PRESSURE WATER



SCHIUMA IN BASSA PRESSIONE
LOW PRESSURE FOAM





CARATTERISTICHE TECNICHE / TECHNICAL FEATURES

Codice Part No.	Acqua Alta Pressione High Pressure Water Program	Schiuma Alta Pressione High Pressure Foam Program	Spazzola Bassa Pressione Low Pressure Brush Program	Tensione Voltage	Potenza Power	Peso Totale Total Weight
3040120002	✓		✓	400 V - 50 Hz R-S-T+N	2700 W	120 kg

ACCESSORI IN DOTAZIONE / SUPPLIED ACCESSORIES

Codice Part No.	Descrizione Description
0235020005	COPERTURA GETTONIERA COIN ACCEPTOR PROTECTION

ACCESSORI A RICHIESTA / ACCESSORIES ON DEMAND

Codice Part No.	Descrizione Description	Codice Part No.	Descrizione Description
0445611050	KIT DISPLAY DISPLAY KIT	1232000200	PORTA LANCIA SPAZZOLA BRUSH LANCE HOLDER
0495022001	KIT EUROKEY NEXT EUROKEY NEXT KIT	0964020012	TUBO ALTA PRESSIONE R1 1/4"-3/8" BSP M BLUE R1 1/4"-3/8" BSP M BLUE HIGH PRESSURE HOSE
0170242011	CASSETTO GETTONIERA LUCCHETTABILE LOCKABLE COIN COMPARTMENT	1031120400	IDROPISTOLA SG31 GIREVOLE G3/8 F CON LANCIA EX28 RND SL - UGELLO 055 25° WASH GUN SG31 SWIVEL G3/8 F WITH LANCE EX28 RND SL - NOZZLE 055 25° 
	AVVIAMENTO MANUALE MANUAL START	1031120600*	IDROPISTOLA SG31 GIREVOLE G3/8 F PERDENTE 1,1 CON LANCIA EX28 RND SL - UGELLO 055 25° WASH GUN SG31 SWIVEL G3/8 F WEEP 1,1 WITH LANCE EX28 RND SL - NOZZLE 055 25° 
0445611047	KIT ILLUMINAZIONE LED LED LIGHT KIT	1031120700*	IDROPISTOLA SG31 GIREVOLE G3/8 F PERDENTE 1,8 CON LANCIA EX28 RND SL - UGELLO 055 25° WASH GUN SG31 SWIVEL G3/8 F WEEP 1,8 WITH LANCE EX28 RND SL - NOZZLE 055 25° 
0445611065	KIT ANTIGELO NO FROST KIT	1031120184	IDROPISTOLA SG31 GIREVOLE G3/8 F FLUSSO LIBERO CON LANCIA RLS L=950 - FB05 + SPAZZOLA WASH GUN SG31 SWIVEL G3/8 F FREE FLOW WITH LANCE RLS L=950 - FB05 + BRUSH 
0445611096	KIT LAVACERCHI / MOSCERINI RIM / INSECT REMOVER KIT	--	ETICHETTA (vedere pag. 179) LABEL (see on pg. 179)
1225020200	BRACCIO VERTICALE (l= 300 mm) VERTICAL BOOM (l= 300 mm)	* A SECONDA DEL VOLUME DI PERDITA ACQUA DESIDERATO ACCORDING THE REQUIRED LEAKAGE	
1225020300	BRACCIO VERTICALE (l= 200 mm) VERTICAL BOOM (l= 200 mm)		
1231000100	PORTA LANCIA SINGOLO SINGLE LANCE HOLDER		

DIMENSIONI
DIMENSIONSIMBALLO (SCATOLA CARTONE)
PACKAGING (CARTON BOX)SCHEMA DI FISSAGGIO BASAMENTO
INSTALLATION SCHEME

A (mm)	B (mm)	C (mm)	X (mm)	Y (mm)	Z (mm)	D (mm)	E (mm)
592	714	1570	900	1700	800	453	600

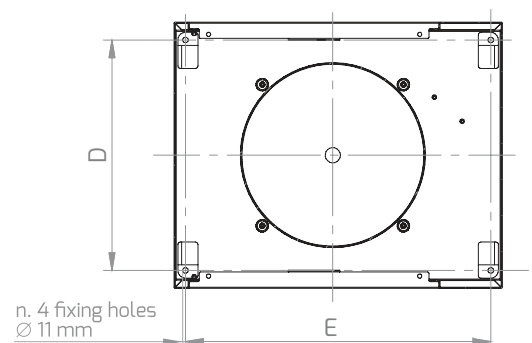
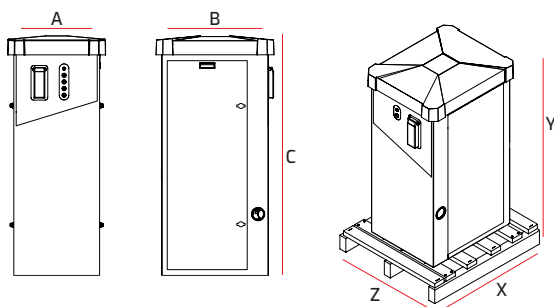



SPW-WASH HP

MODULO PRELAVAGGIO IN ALTA PRESSIONE / HIGH PRESSURE PRE-WASH MODULE

CARATTERISTICHE / FEATURES

- ❖ MODULO SELF-SERVICE DEDICATO AL PRELAVAGGIO CON EROGAZIONE DI ACQUA IN ALTA PRESSIONE, ADATTO A TUTTI I MEZZI DI TRASPORTO
 - ❖ STRUTTURA IN ACCIAIO INOX AISI 304
 - ❖ POMPA ALTA PRESSIONE (100 bar - 13 l/m) CON GIUNTO ELASTICO
 - ❖ CHIUSURA A DUE PUNTI ANTIVANDALO
 - ❖ CALOTTA IN ABS RESISTENTE AI RAGGI UV
 - ❖ QUADRO ELETTRICO E GETTONIERA INTEGRATI DI FACILE ACCESSO
 - ❖ TEMPO CICLO PROGRAMMABILE

 - ❖ SELF-SERVICE MODULE DEDICATE TO HIGH PRESSURE WATER PRE-WASH, SUITABLE FOR ALL MEANS OF TRANSPORT
 - ❖ AISI 304 STAINLESS STEEL CABINET
 - ❖ HIGH PRESSURE PUMP (100 bar - 13 l/m) WITH ELASTIC FLEXIBLE JOINT
 - ❖ VANDAL-PROOF DOORS AND LOCKS
 - ❖ ABS COVER, RESISTANT TO UV RAYS
 - ❖ EASY ACCESS INTEGRATED CONTROL BOARD
 - ❖ PROGRAMMABLE CYCLE TIME



ACCESSORI A RICHIESTA / ACCESSORIES ON DEMAND

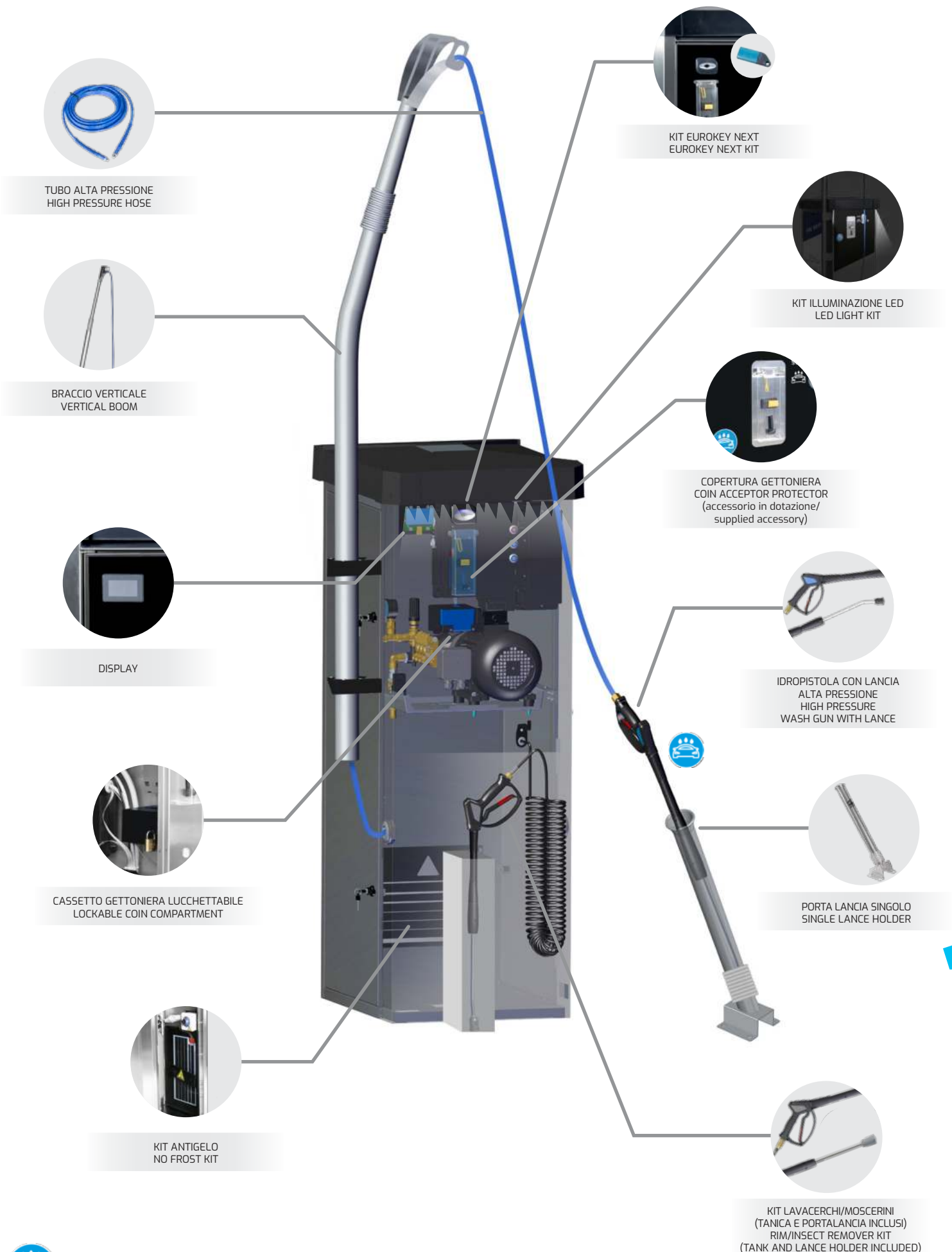

TUBO ALTA PRESSIONE
HIGH PRESSURE HOSE



BRACCIO VERTICALE
VERTICAL BOOM

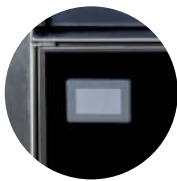

DISPLAY



CASSETTO GETTONIERA LUCCHETTABILE
LOCKABLE COIN COMPARTMENT



KIT ANTIGELO
NO FROST KIT



KIT EUROKEY NEXT
EUROKEY NEXT KIT



KIT ILLUMINAZIONE LED
LED LIGHT KIT



COPERTURA GETTONIERA
COIN ACCEPTOR PROTECTOR
(accessorio in dotazione/
supplied accessory)



IDROPISTOLA CON LANCIA
ALTA PRESSIONE
HIGH PRESSURE
WASH GUN WITH LANCE

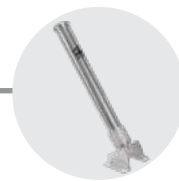

PORTA LANCIA SINGOLO
SINGLE LANCE HOLDER



KIT LAVACERCHI/MOSKERINI
(TANICA E PORTALANCIA INCLUSI)
RIM/INSECT REMOVER KIT
(TANK AND LANCE HOLDER INCLUDED)



ACQUA IN ALTA PRESSIONE
HIGH PRESSURE WATER



CARATTERISTICHE TECNICHE / TECHNICAL FEATURES

Codice Part No.	Acqua Alta Pressione High Pressure Water Program	Schiuma Alta Pressione High Pressure Foam Program	Spazzola Bassa Pressione Low Pressure Brush Program	Tensione Voltage	Potenza Power	Peso Totale Total Weight
3040120001	✓			400 V - 50 Hz R-S-T+N	2500 W	115 kg

ACCESSORI IN DOTAZIONE / SUPPLIED ACCESSORIES

Codice Part No.	Descrizione Description
0235020005	COPERTURA GETTONIERA COIN ACCEPTOR PROTECTION

ACCESSORI A RICHIESTA / ACCESSORIES ON DEMAND

Codice Part No.	Descrizione Description	Codice Part No.	Descrizione Description
0445611050	KIT DISPLAY DISPLAY KIT	1225020200	BRACCIO VERTICALE (l= 300 mm) VERTICAL BOOM (l= 300 mm)
0495022001	KIT EUROKEY NEXT EUROKEY NEXT KIT	1225020300	BRACCIO VERTICALE (l= 200 mm) VERTICAL BOOM (l= 200 mm)
0170242011	CASSETTO GETTONIERA LUCCHETTABILE LOCKABLE COIN COMPARTMENT	1231000100	PORTA LANCIA SINGOLO SINGLE LANCE HOLDER
	AVVIAMENTO MANUALE MANUAL START	0964020012	TUBO ALTA PRESSIONE R1 1/4"-3/8" BSP M BLUE R1 1/4"-3/8" BSP M BLUE HIGH PRESSURE HOSE
0445611047	KIT ILLUMINAZIONE LED LED LIGHT KIT	1031120400	IDROPISTOLA SG31 GIREVOLE G3/8 F CON LANCIA EX28 RND SL - UGELLO 055 25° WASH GUN SG31 SWIVEL G3/8 F WITH LANCE EX28 RND SL - NOZZLE 055 25° 
0445611065	KIT ANTIGELO NO FROST KIT	1031120600*	IDROPISTOLA SG31 GIREVOLE G3/8 F PERDENTE 1,1 CON LANCIA EX28 RND SL - UGELLO 055 25° WASH GUN SG31 SWIVEL G3/8 F WEEP 1,1 WITH LANCE EX28 RND SL - NOZZLE 055 25° 
0445611096	KIT LAVACERCHI / MOSCERINI RIM / INSECT REMOVER KIT	1031120700*	IDROPISTOLA SG31 GIREVOLE G3/8 F PERDENTE 1,8 CON LANCIA EX28 RND SL - UGELLO 055 25° WASH GUN SG31 SWIVEL G3/8 F WEEP 1,8 WITH LANCE EX28 RND SL - NOZZLE 055 25° 
		--	ETICHETTA (vedere pag. 179) LABEL (see on pg. 179)

* A SECONDA DEL VOLUME DI PERDITA ACQUA DESIDERATO
ACCORDING THE REQUIRED LEAKAGE

DIMENSIONI
DIMENSIONSIMBALLO (SCATOLA CARTONE)
PACKAGING (CARTON BOX)SCHEMA DI FISSAGGIO BASAMENTO
INSTALLATION SCHEME

A (mm)	B (mm)	C (mm)	X (mm)	Y (mm)	Z (mm)	D (mm)	E (mm)
592	714	1570	900	1700	800	453	600

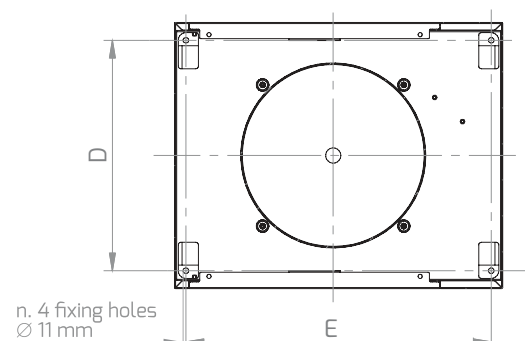
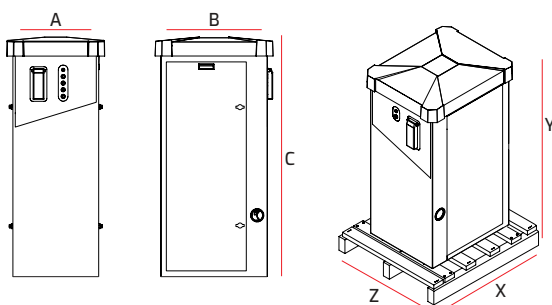



SFT

MODULO PRELAVAGGIO SCHIUMA IN ALTA PRESSIONE / SELF HIGH PRESSURE FOAM TOWER

CARATTERISTICHE / FEATURES

▲ STRUTTURA IN ACCIAIO INOX AISI 304

▲ AISI 304 STAINLESS STEEL CABINET

▲ POMPA PER SCHIUMA ALTA PRESSIONE

▲ HIGH PRESSURE FOAM PUMP

▲ POMPA DOSATRICE

▲ DOSING PUMP

▲ CHIUSURA A DUE PUNTI ANTIVANDALO

▲ VANDAL-PROOF DOORS AND LOCKS

▲ CALOTTA IN ABS RESISTENTE AI RAGGI UV

▲ ABS COVER, RESISTANT TO UV RAYS

▲ QUADRO ELETTRICO E GETTONIERA INTEGRATI DI FACILE ACCESSO

▲ EASY ACCESS INTEGRATED CONTROL BOARD

▲ TEMPO CICLO PROGRAMMABILE

▲ PROGRAMMABLE CYCLE TIME



ACCESSORI A RICHIESTA / ACCESSORIES ON DEMAND

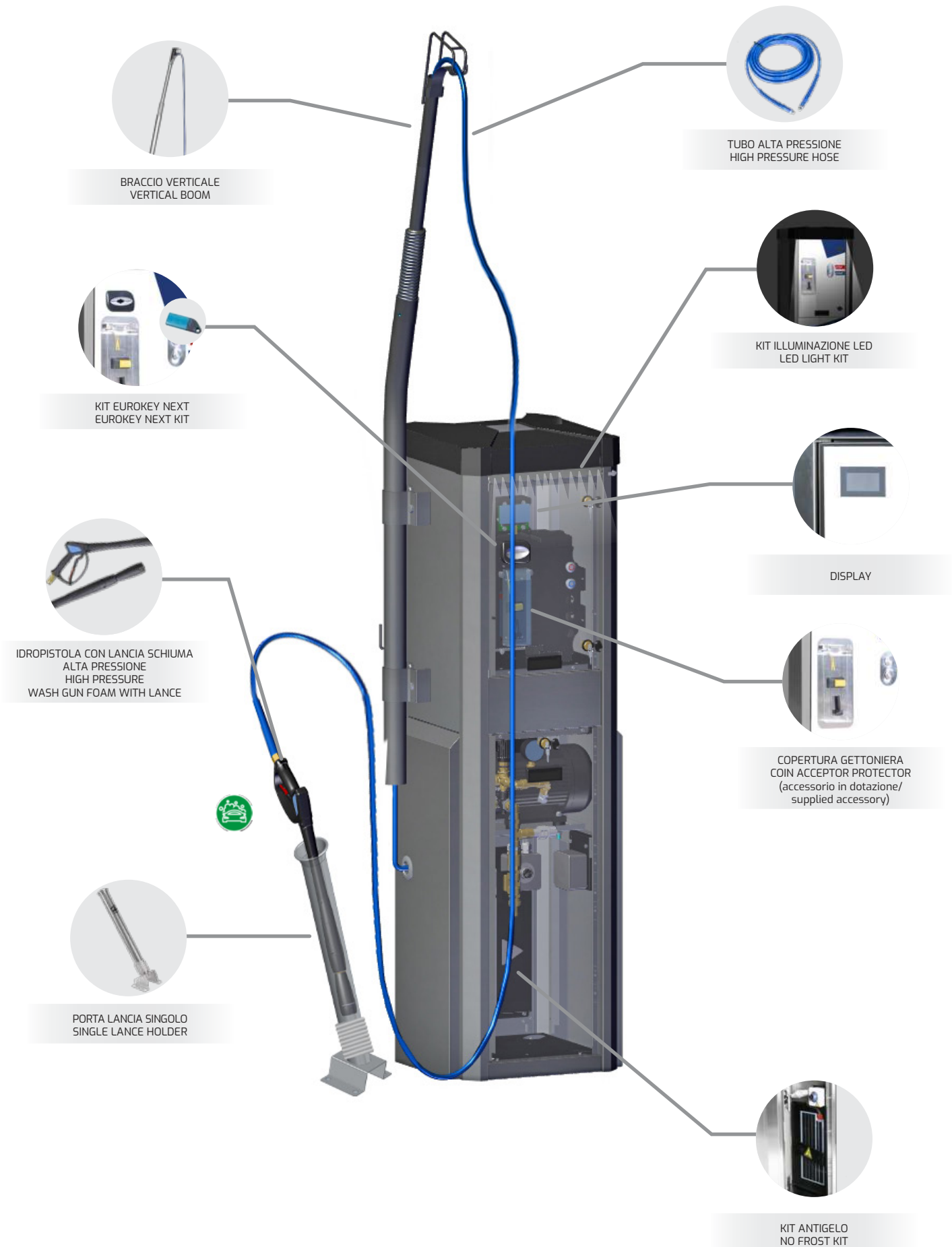

SCHIUMA IN ALTA PRESSIONE
HIGH PRESSURE FOAM

CARATTERISTICHE TECNICHE / TECHNICAL FEATURES

Codice Part No.	Potenza Power	Tensione Voltage	Alimentazione Power Supply	Peso Totale Total Weight
3040120030	1,8 kW	400 V - 50 Hz	400 V - 50 Hz R-S-T+N	65 kg

ACCESSORI IN DOTAZIONE / SUPPLIED ACCESSORIES

Codice Part No.	Descrizione Description
0235020005	COPERTURA GETTONIERA COIN ACCEPTOR PROTECTION

ACCESSORI A RICHIESTA / ACCESSORIES ON DEMAND

Codice Part No.	Descrizione Description	Codice Part No.	Descrizione Description
0495022001	KIT EUROKEY NEXT EUROKEY NEXT KIT	1231000100	PORTA LANCIA SINGOLO SINGLE LANCE HOLDER
0445611105	KIT ILLUMINAZIONE LED LED LIGHT KIT	0964020012	TUBO ALTA PRESSIONE R1 1/4"-3/8" BSP M BLUE R1 1/4"-3/8" BSP M BLUE HIGH PRESSURE HOSE
0445611050	DISPLAY	1031120185	IDROPISTOLA SG31 GIREVOLE G3/8 F CON PROLUNGA EX28 RND SL - FH35 UGELLO 040 WASH GUN SG31 SWIVEL G3/8 F WITH EXTENSION EX28 RND SL - FH35 NOZZLE 040
0445611106	KIT ANTIGELO NO FROST KIT	1031120385*	IDROPISTOLA SG31 GIREVOLE G3/8 F PERDENTE 1,1 CON PROLUNGA EX28 RND SL - FH35 UGELLO 040 WASH GUN SG31 SWIVEL G3/8 F WEEP 1,1 WITH EXTENSION EX28 RND SL - FH35 NOZZLE 040
1225020200	BRACCIO VERTICALE (l= 300 mm) VERTICAL BOOM (l= 300 mm)	1031120485*	IDROPISTOLA SG31 GIREVOLE G3/8 F PERDENTE 1,8 CON PROLUNGA EX28 RND SL - FH35 UGELLO 040 WASH GUN SG31 SWIVEL G3/8 F WEEP 1,8 WITH EXTENSION EX28 RND SL - FH35 NOZZLE 040
1225020300	BRACCIO VERTICALE (l= 200 mm) VERTICAL BOOM (l= 200 mm)	--	ETICHETTA (vedere pag. 179) LABEL (see on pg. 179)

* A SECONDA DEL VOLUME DI PERDITA ACQUA DESIDERATO
ACCORDING THE REQUIRED LEAKAGE

DIMENSIONI
DIMENSIONSIMBALLO (SCATOLA CARTONE)
PACKAGING (CARTON BOX)SCHEMA DI FISSAGGIO BASAMENTO
INSTALLATION SCHEME

A (mm)	B (mm)	C (mm)	X (mm)	Y (mm)	Z (mm)	D (mm)	E (mm)
420	425	1550	800	1680	900	278	278

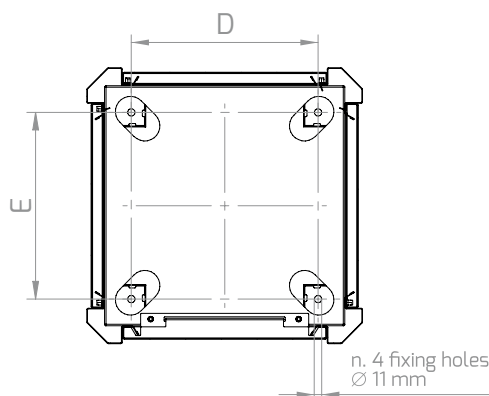
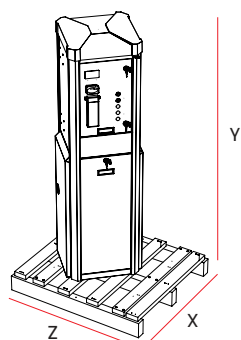
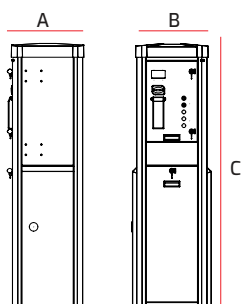

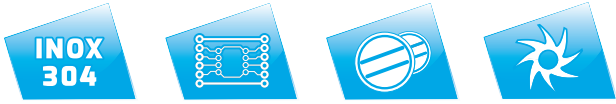

ABW

COLONNINA ASCIUGA AUTO-MOTO / AUTO-MOTORCYCLE DRYING COLUMN

CARATTERISTICHE / FEATURES

- COLONNINA UNIVERSALE PER L'ASCIUGATURA: UN VELO D'ARIA SOFFIATA AD ALTA POTENZA E RISCALDATA ASCIUGA LA CARROZZERIA, I TAPPETINI E LE VARIE SUPERFICI EVITANDO LA FORMAZIONE DI ALONI.
 - MANICHETTA SOFFIANTE ERGONOMICA, SNODATA CON SISTEMA ANTIURTO ED ANTIGRAFFIO
 - BRACCIO A MOLLA VERTICALE INOX PER LA FACILE MOVIMENTAZIONE DELLA MANICHETTA SOFFIANTE
 - STRUTTURA PORTANTE MODULARE
 - CHIUSURA A DUE PUNTI ANTIVANDALO
 - CONTENITORE GETTONI LUCCHETTABILE
 - TEMPO CICLO PROGRAMMABILE
 - AVVIAMENTO MANUALE A RICHIESTA
 - CALOTTA IN ABS RESISTENTE AI RAGGI UV
 - QUADRO ELETTRICO E GETTONIERA INTEGRATI E DI FACILE ACCESSO

 - UNIVERSAL COLUMN FOR CAR DRYING: A BLOW OF HIGH POWER AND HEATED AIR DRIES THE BODYWORK, MATS AND VARIOS SURFACES, PREVENTING THE FORMATION OF HALO
 - ERGONOMIC BLOWER COUPLING, ARTICULATED WITH ANTI-SHOCK AND ANTI-SCRATCH SYSTEM
 - S.STEEL VERTICAL BOOM FOR EASY HANDLING OF THE BLOWER COUPLING
 - REINFORCED MODULAR FRAME
 - VANDAL-PROOF DOORS AND LOCKS
 - LOCKABLE TOKEN/COIN COMPARTMENT
 - PROGRAMMABLE CYCLE TIME
 - MANUAL START ON DEMAND
 - ABS COVER, RESISTANT TO UV RAYS
 - EASY ACCESS INTEGRATED CONTROL BOARD



ACCESSORI IN DOTAZIONE / SUPPLIED ACCESSORIES

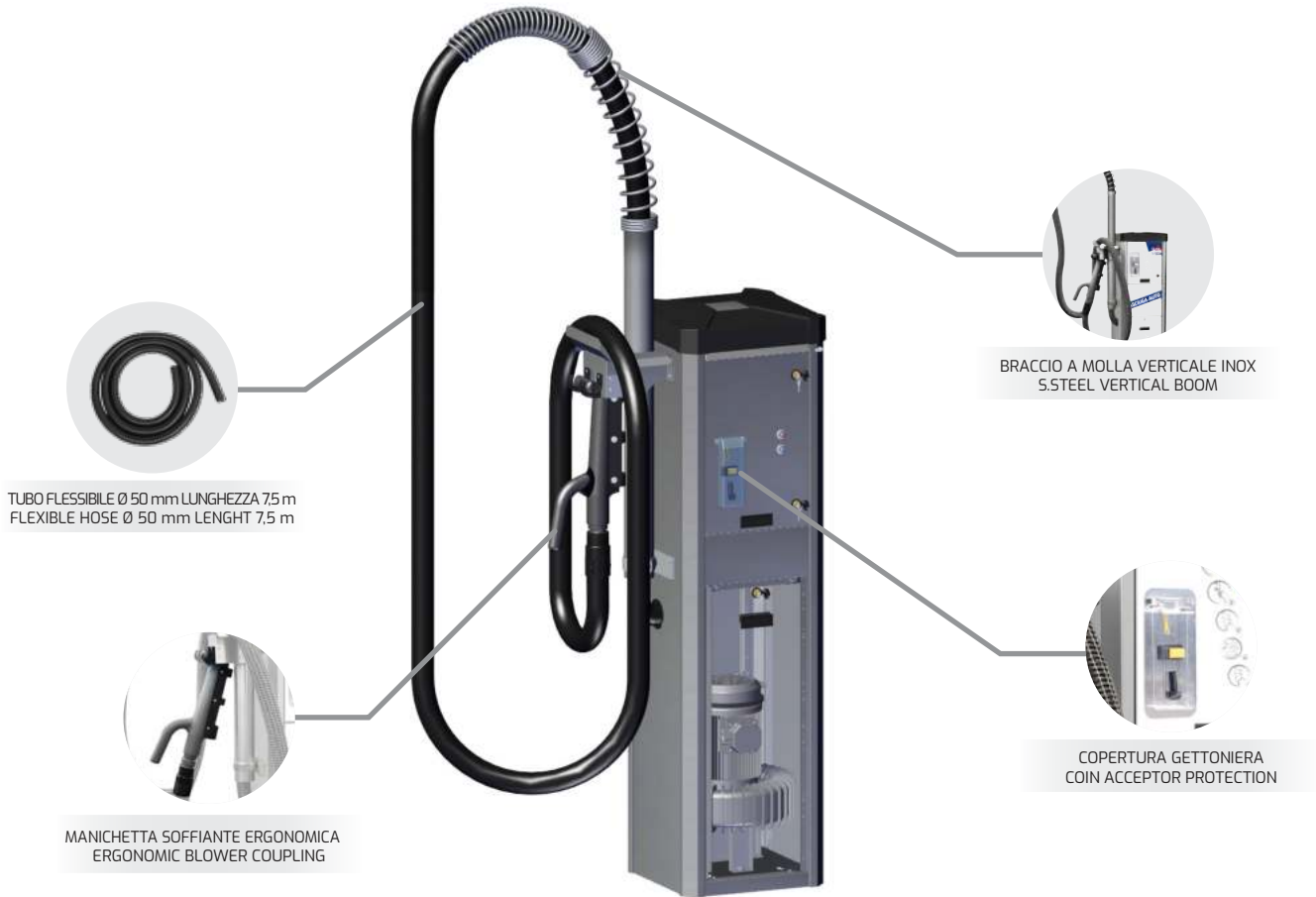

TUBO FLESSIBILE Ø 50 mm LUNGHEZZA 7,5 m
FLEXIBLE HOSE Ø 50 mm LENGHT 7,5 m

BRACCIO A MOLLA VERTICALE INOX
S.STEEL VERTICAL BOOM

MANICHETTA SOFFIANTE ERGONOMICA
ERGONOMIC BLOWER COUPLING

COPERTURA GETTONIERA
COIN ACCEPTOR PROTECTION

ACCESSORI A RICHIESTA / ACCESSORIES ON DEMAND



KIT ILLUMINAZIONE LED
LED LIGHT KIT

KIT EUROKEY NEXT
EUROKEY NEXT KIT

DISPLAY

CARATTERISTICHE TECNICHE / TECHNICAL FEATURES

Codice Part No.	Potenza Power	Tensione Voltage	Portata d'Aria Air Flow	Alimentazione Power Supply	Peso Weight
3050140001	3kW	400 V - 50 Hz	370 m ³ /h	400 V - 50 Hz R-S-T+N	65 kg

ACCESSORI IN DOTAZIONE / SUPPLIED ACCESSORIES

Codice Part No.	Descrizione Description
0235020005	COPERTURA GETTONIERA COIN ACCEPTOR PROTECTION
0090611003	BOCCHETTA DI ASCIUGATURA DRYING CREVICE TOOL
0964550029	TUBO FLESSIBILE (Ø 50 mm l= 7,5 m) FLEXIBLE HOSE (Ø 50 mm l= 7,5 m)
0102611001	BRACCIO A MOLLA VERTICALE INOX S-STEEL VERTICAL BOOM

ACCESSORI A RICHIESTA / ACCESSORIES ON DEMAND

Codice Part No.	Descrizione Description
0495022001	KIT EUROKEY NEXT EUROKEY NEXT KIT
0445611105	KIT ILLUMINAZIONE LED LED LIGHT KIT
0445611050	DISPLAY
--	ETICHETTA (vedere pag. 179) LABEL (see on pg. 179)

DIMENSIONI
DIMENSIONSIMBALLO (PALLET LEGNO + SCATOLA CARTONE)
PACKAGING (WOOD PALLET + CARTON BOX)SCHEMA DI FISSAGGIO BASAMENTO
INSTALLATION SCHEME

A (mm)	B (mm)	C (mm)	X (mm)	Y (mm)	Z (mm)	D (mm)	E (mm)
420	420	1550	800	1680	900	278	278

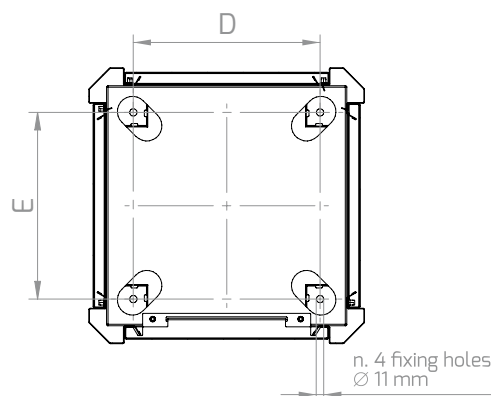
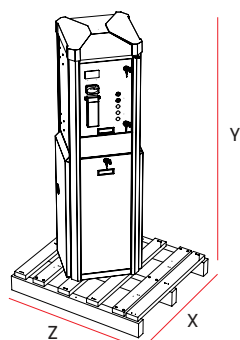
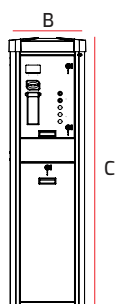
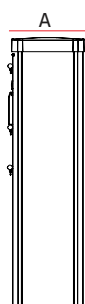



MBW

COLONNINA MULTIFUNZIONE PER LAVAGGIO MOTOCICLI / MULTIFUNCTION COLUMN FOR MOTORCYCLE CLEANING

CARATTERISTICHE / FEATURES

- ▲ COLONNINA UNIVERSALE PER PULIZIA APPROFONDATA DI MOTOCICLI ▲ UNIVERSAL COLUMN FOR MOTORCYCLE CLEANING
- ▲ L'ALTERNATIVA IDEALE AL LAVAGGIO AD ALTA PRESSIONE, DANGEROLO PER CARENATURE, ADESIVE, COMPONENTISTICA ELETTRICA ESPOSTA ▲ AN EXCELLENT OPTION TO THE HIGH PRESSURE CLEANING, DANGEROUS TO BIKE'S INTERNALS AND EXTERIOR COMPONENTS
- ▲ STRUTTURA IN ACCIAIO INOX AISI 304 ▲ AISI 304 STAINLESS STEEL CABINET
- ▲ PISTOLA CON UGELLO PER EROGAZIONE ACQUA IN MEDIA PRESSIONE ▲ MEDIUM PRESSURE WATER SPRAY GUN
- ▲ PISTOLA CON SPAZZOLA IN SETOLA NATURALE PER EROGAZIONE ACQUA+DETERGENTE IN BASSA PRESSIONE ▲ LOW PRESSURE WATER+DETERGENT SPRAY GUN WITH BRUSH
- ▲ IMPIANTO DI ASCIUGATURA CON SOFFIAGGIO ARIA ▲ AIR BLOW DRYING SYSTEM
- ▲ GANCIO APPENDI CASCO/GIUBBOTTO/ZAINO ▲ HOOK HANGER HELMET, JACKET, BACKPACK
- ▲ ARROTOLATORE TUBO ACQUA 12 m CON FERMO E RIAVVOLGIMENTO AUTOMATICO ▲ 12 m HOSE REEL WITH LOCKING SYSTEM AND AUTOMATIC REWIND
- ▲ QUADRO ELETTRICO E GETTONIERA INTEGRATI E DI FACILE ACCESSO ▲ EASY ACCESS INTEGRATED CONTROL BOARD
- ▲ TEMPO CICLO E POMPA DOSATRICE DETERGENTE REGOLABILE ▲ ADJUSTABLE FLOW DETERGENT PUMP AND CYCLE TIME
- ▲ SPORTELLINO ANTERIORE FACILMENTE RIMOVIBILE PER INTERVENTI DI MANUTENZIONE ▲ FRONT COVER PANEL EASY TO REMOVE FOR MAINTENANCE OPERATIONS
- ▲ CHIUSURA A DUE PUNTI ANTIVANDALO ▲ VANDAL-PROOF DOORS AND LOCKS
- ▲ CALOTTA IN ABS RESISTENTE AI RAGGI UV ▲ ABS COVER, RESISTANT TO UV RAYS
- ▲ PRODOTTI CHIMICI NON FORNITI ▲ CHEMICAL PRODUCTS NOT INCLUDED

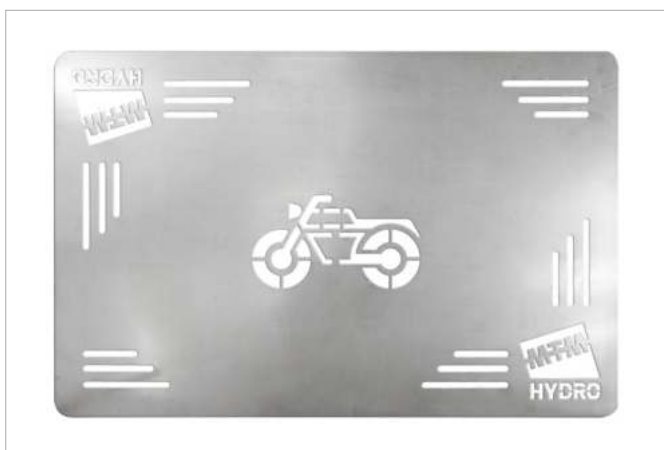

ACCESSORI A RICHIESTA / ACCESSORIES ON DEMAND

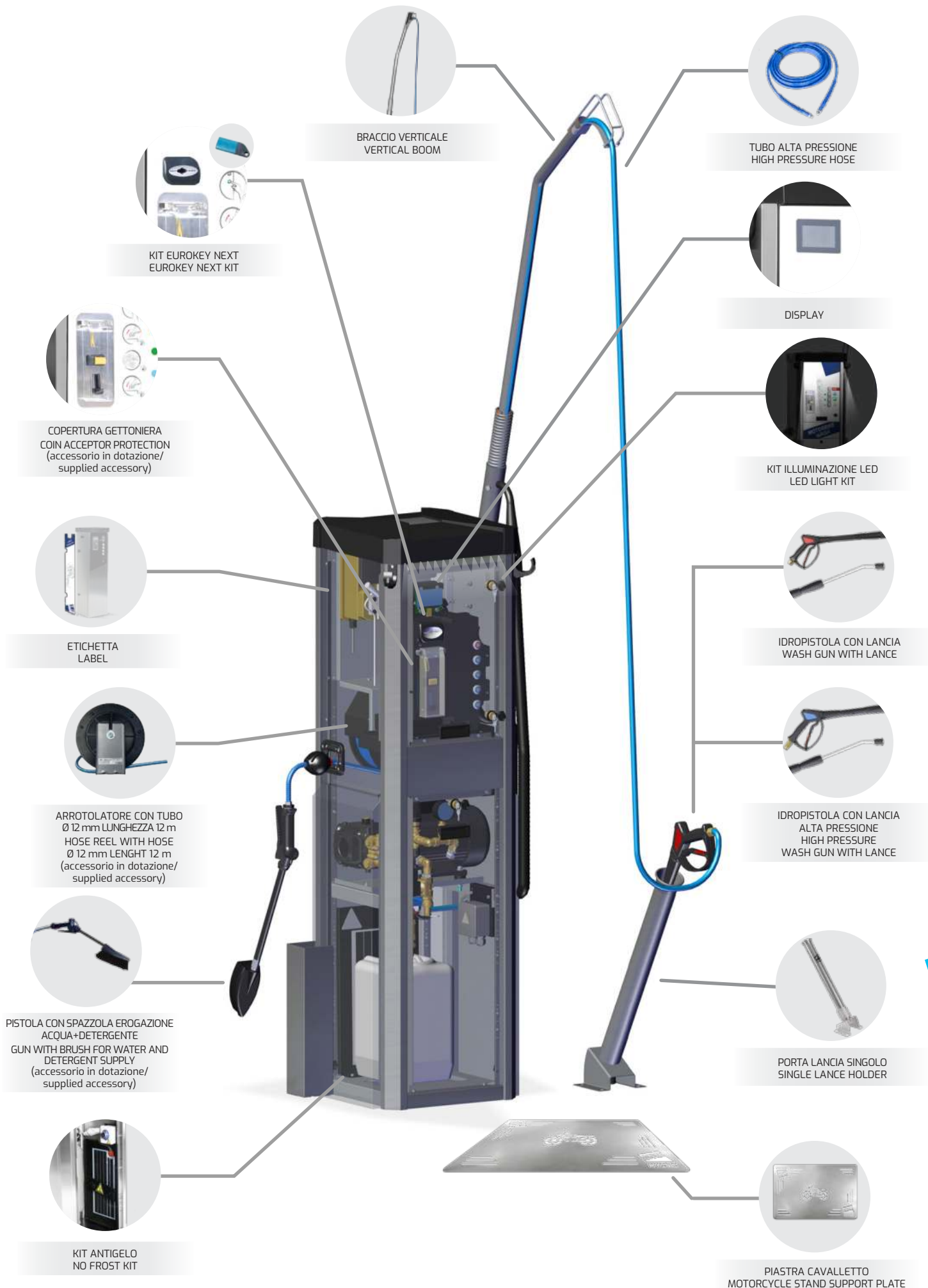

BRACCIO VERTICALE
VERTICAL BOOM



TUBO ALTA PRESSIONE
HIGH PRESSURE HOSE



KIT EUROKEY NEXT
EUROKEY NEXT KIT



DISPLAY



COPERTURA GETTONIERA
COIN ACCEPTOR PROTECTION
(accessorio in dotazione/
supplied accessory)



KIT ILLUMINAZIONE LED
LED LIGHT KIT



ETICHETTA
LABEL



IDROPISTOLA CON LANCIA
WASH GUN WITH LANCE



ARROTOLATORE CON TUBO
Ø 12 mm LUNGHEZZA 12 m
HOSE REEL WITH HOSE
Ø 12 mm LENGHT 12 m
(accessorio in dotazione/
supplied accessory)



IDROPISTOLA CON LANCIA
ALTA PRESSIONE
HIGH PRESSURE
WASH GUN WITH LANCE



PISTOLA CON SPAZZOLA EROGAZIONE
ACQUA+DETERGENTE
GUN WITH BRUSH FOR WATER AND
DETERGENT SUPPLY
(accessorio in dotazione/
supplied accessory)



PORTA LANCIA SINGOLO
SINGLE LANCE HOLDER



KIT ANTIGELO
NO FROST KIT



PIASTRA CAVALLETTO
MOTORCYCLE STAND SUPPORT PLATE

CARATTERISTICHE TECNICHE / TECHNICAL FEATURES

Codice Part No.	Potenza Power	Tensione Voltage	Alimentazione Power Supply	Peso Totale Total Weight
3040120040	2 kW	400 V - 50 Hz	400 V - 50 Hz R-S-T+N	72 kg

ACCESSORI IN DOTAZIONE / SUPPLIED ACCESSORIES

Codice Part No.	Descrizione Description
0235020005	COPERTURA GETTONIERA COIN ACCEPTOR PROTECTION
0048020001	ARROTOLATORE CON TUBO Ø 12 mm LUNGHEZZA 12 m HOSE REELS WITH HOSE Ø 12 mm Length 12 m
0667611009	PISTOLA CON SPAZZOLA EROGAZIONE ACQUA+DETERGENTE GUN WITH BRUSH FOR WATER AND DETERGENT SUPPLY

ACCESSORI A RICHIESTA / ACCESSORIES ON DEMAND

Codice Part No.	Descrizione Description	Codice Part No.	Descrizione Description
0445611050	KIT DISPLAY DISPLAY KIT	0964020012	TUBO ALTA PRESSIONE R1 1/4"-3/8" BSP M BLUE R1 1/4"-3/8" BSP M BLUE HIGH PRESSURE HOSE
0495022001	KIT EUROKEY NEXT EUROKEY NEXT KIT	1231000100	PORTA LANCIA SINGOLO SINGLE LANCE HOLDER
0445611105	KIT ILLUMINAZIONE LED LED LIGHT KIT	1031121000	IDROPISTOLA SG31 GIREVOLE G3/8 F CON LANCIA EX28 RND SL - UGELLO 065 25° SG31 SWIVEL INLET WASH GUN WITH EX28 RND SL LANCE - 065 25° NOZZLE
0445611106	KIT ANTIGELO NO FROST KIT	1031121100	IDROPISTOLA SG31 GIREVOLE PERDENTE PERMANENTE 1,1 L G3/8 F CON LANCIA EX28 RND SL - UGELLO 065 25° SG31 SWIVEL INLET PERMANENT WEEP 1,1 L WASH GUN WITH EX28 RND SL LANCE - 065 25° NOZZLE
1225020200	BRACCIO VERTICALE (l= 300 mm) VERTICAL BOOM (l= 300 mm)	1031121200	IDROPISTOLA SG31 GIREVOLE PERDENTE PERMANENTE 1,8 L G3/8 F CON LANCIA EX28 RND SL - UGELLO 065 25° SG31 SWIVEL INLET PERMANENT WEEP 1,8 L WASH GUN WITH EX28 RND SL LANCE - 065 25° NOZZLE
1225020300	BRACCIO VERTICALE (l= 200 mm) VERTICAL BOOM (l= 200 mm)	--	ETICHETTA (vedere pag. 179) LABEL (see on pg. 179)
0650611012	PIASTRA CAVALLETTO MOTORCYCLE STAND SUPPORT PLATE		

DIMENSIONI
DIMENSIONSIMBALLO (SCATOLA CARTONE)
PACKAGING (CARTON BOX)SCHEMA DI FISSAGGIO BASAMENTO
INSTALLATION SCHEME

A (mm)	B (mm)	C (mm)	X (mm)	Y (mm)	Z (mm)	D (mm)	E (mm)
420	425	1550	800	1680	900	278	278

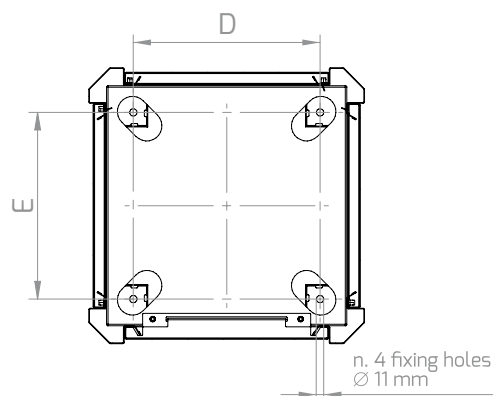
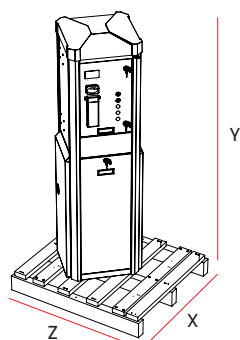
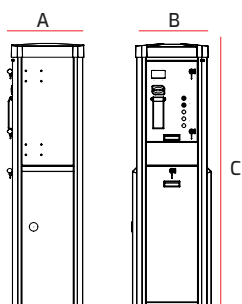



BKW

COLONNINA MULTIFUNZIONE PER LAVAGGIO BICICLETTE / MULTIFUNCTION COLUMN FOR BICYCLE WASHING

CARATTERISTICHE / FEATURES

- ▲ COLONNINA UNIVERSALE PER PULIZIA APPROFONDATA DI BICICLETTE DI TUTTI I TIPI ▲ UNIVERSAL COLUMN TO CLEAN CAREFULLY ALL BIKES MODELS
- ▲ L'ALTERNATIVA IDEALE AL LAVAGGIO AD ALTA PRESSIONE, DANNOSO PER GUARNIZIONI E CUSCINETTI ▲ AN EXCELLENT OPTION TO THE HIGH PRESSURE CLEANING, DANGEROUS TO SEALS AND BEARINGS
- ▲ PISTOLA CON UGELLO PER EROGAZIONE ACQUA IN BASSA PRESSIONE ▲ LOW PRESSURE WATER SPRAY GUN
- ▲ PISTOLA CON SPAZZOLA PER EROGAZIONE ACQUA+DETERGENTE IN BASSA PRESSIONE ▲ LOW PRESSURE WATER+DETERGENT SPRAY GUN WITH BRUSH
- ▲ IMPIANTO DI ASCIUGATURA CON SOFFIAGGIO ARIA ▲ AIR BLOW DRYING SYSTEM
- ▲ BRACCIO "REGGI BICI" UNIVERSALE, ADATTO AD OGNI MODELLO ▲ UNIVERSAL BIKE HOLDER, FIT FOR ALL BIKES MODELS
- ▲ ARROTOLATORI TUBI ACQUA 12 m CON FERMO E RIAVVOLGIMENTO AUTOMATICO ▲ 12 m HOSE REEL WITH BLOCK SYSTEM AND AUTOMATIC REWIND
- ▲ KIT GONFIAGOMME CON COMPRESSORE INCORPORATO (BKW TI) ▲ TIRE INFLATORS KIT WITH COMPRESSOR (BKW TI)
- ▲ TEMPO CICLO E POMPA DOSATRICE DETERGENTE REGOLABILE ▲ ADJUSTABLE DETERGENT PUMP AND CYCLE TIME
- ▲ CHIUSURA A DUE PUNTI ANTIVANDALO ▲ VANDAL-PROOF DOORS AND LOCKS
- ▲ AVVIAMENTO MANUALE A RICHIESTA ▲ MANUAL START ON DEMAND
- ▲ CALOTTA IN ABS RESISTENTE AI RAGGI UV ▲ ABS COVER, RESISTANT TO UV RAYS
- ▲ PRODOTTI CHIMICI NON FORNITI ▲ CHEMICAL PRODUCTS NOT INCLUDED
- ▲ QUADRO ELETTRICO E GETTONIERA INTEGRATI E DI FACILE ACCESSO ▲ EASY ACCESS INTEGRATED CONTROL BOARD
- ▲ SPORTELLO POSTERIORE FACILMENTE RIMOVIBILE PER INTERVENTI DI MANUTENZIONE ▲ REAR COVER PANELS EASY TO REMOVE FOR MAINTENANCE OPERATIONS



ACCESSORI IN DOTAZIONE / SUPPLIED ACCESSORIES

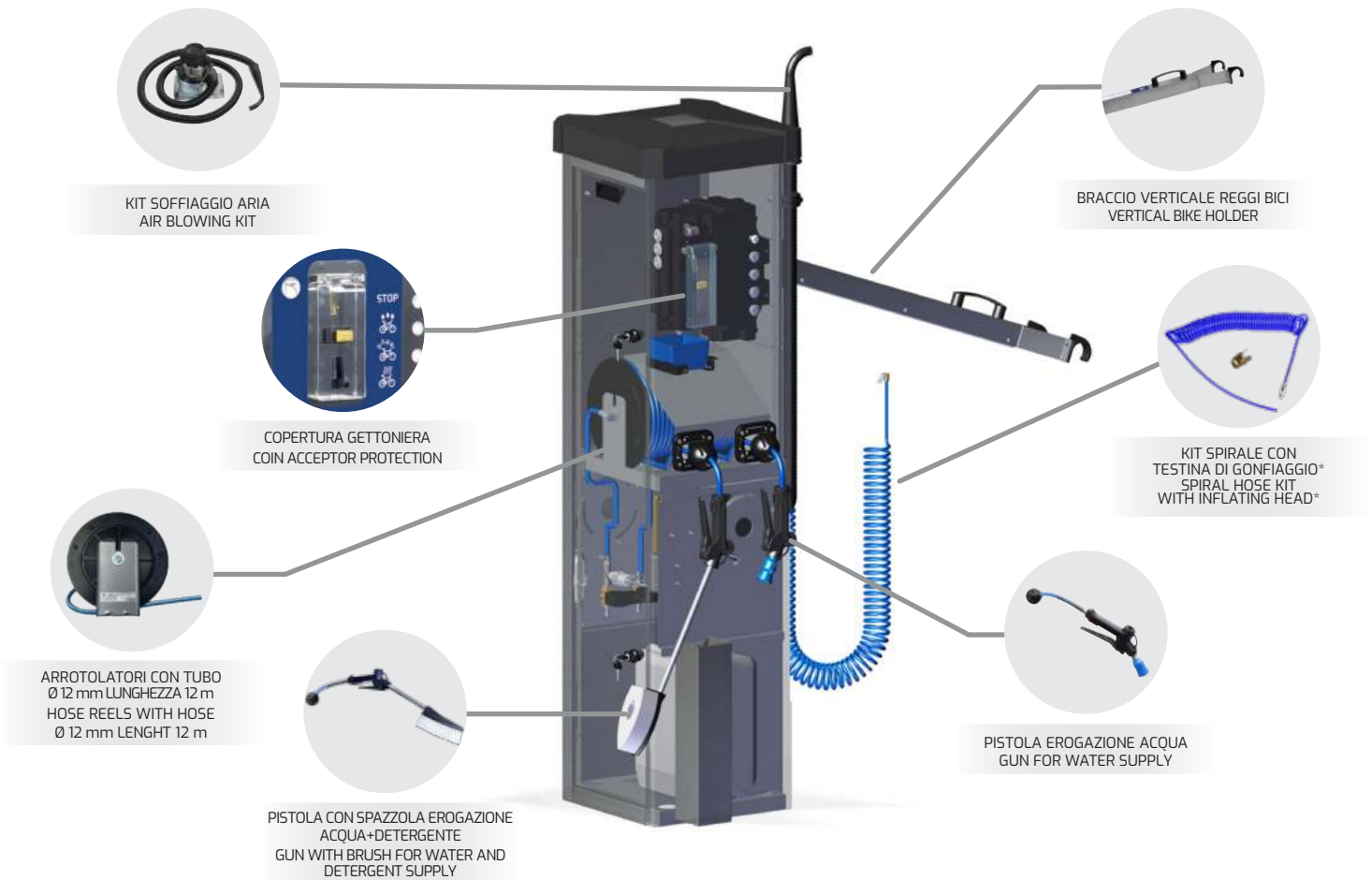

ACCESSORI A RICHIESTA / ACCESSORIES ON DEMAND

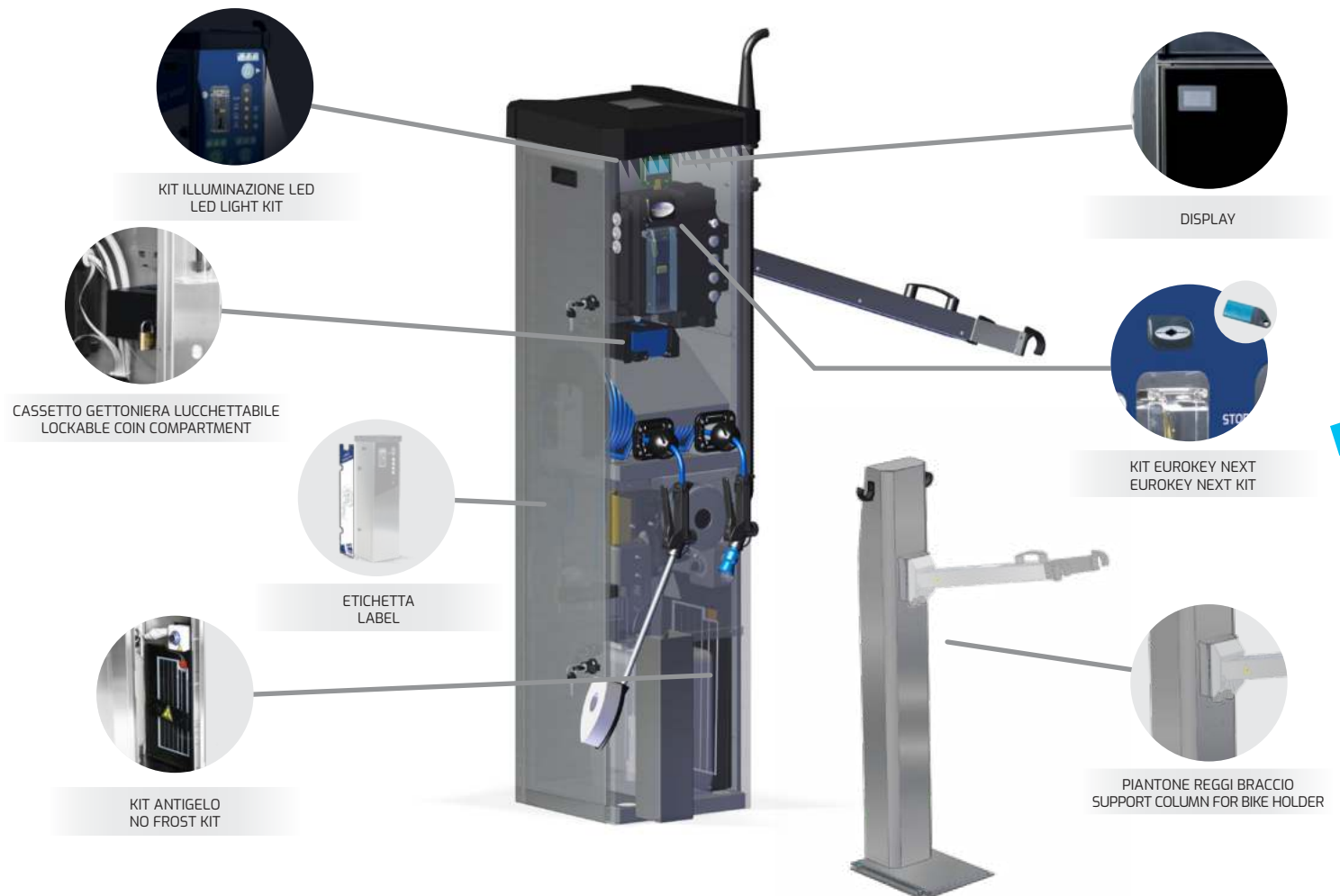

CARATTERISTICHE TECNICHE / TECHNICAL FEATURES

Codice Part No.	Descrizione Description	Kit Gonggiomme Tire Inflators Kit	Alimentazione Power supply	Potenza Power	Capacità serbatoio detergente Detergent Tank Capacity	Peso Weight
3040120020	BKW		230V - 50 Hz	1100W	11 l	60 Kg
3040120022	BKW TI	✓	230V - 50 Hz	1350W	11 l	65 Kg

ACCESSORI IN DOTAZIONE / SUPPLIED ACCESSORIES

ACCESSORI A RICHIESTA / ACCESSORIES ON DEMAND

Codice Part No.	Descrizione Description	Codice Part No.	Descrizione Description
0102611006	BRACCIO UNIVERSALE REGGI BICI UNIVERSAL BIKE HOLDER	0905611036	PIANTONE REGGI BRACCIO SUPPORT COLUMN FOR BIKE HOLDER
0875611017*	KIT SPIRALE CON TESTINA DI GONFIAGGIO SPIRAL HOSE KIT WITH INFLATING HEAD	0495022001	KIT EUROKEY NEXT EUROKEY NEXT KIT
0048020001	ARROTOLATORE CON TUBO Ø 12 mm LUNGHEZZA 12 m HOSE REELS WITH HOSE Ø 12 mm Length 12 m	0170242011	CASSETTO GETTONIERA LUCCHETTABILE LOCKABLE COIN COMPARTMENT
0667611006	PISTOLA EROGAZIONE ACQUA GUN FOR WATER SUPPLY	0445611036	KIT ILLUMINAZIONE LED LED LIGHT KIT
0667611007	PISTOLA CON SPAZZOLA EROGAZIONE ACQUA+DETERGENTE GUN WITH BRUSH FOR WATER AND DETERGENT SUPPLY	0445611050	KIT DISPLAY DISPLAY KIT
0445611090	KIT SOFFIAGGIO ARIA AIR BLOWING KIT	0445611048	KIT ANTIGELO NO FROST KIT
0235020005	COPERTURA GETTONIERA COIN ACCEPTOR PROTECTION	--	ETICHETTA (vedere pag. 179) LABEL (see on pg. 179)

* Accessorio in dotazione solo nella versione BKW TI - Supplied accessories only in BKW TI version

DIMENSIONI
DIMENSIONSIMBALLO (SCATOLA CARTONE)
PACKAGING (CARTON BOX)SCHEMA DI FISSAGGIO BASAMENTO
INSTALLATION SCHEME

A (mm)	B (mm)	C (mm)	X (mm)	Y (mm)	Z (mm)	D (mm)	E (mm)
420	420	1550	1785	608	500	250	300

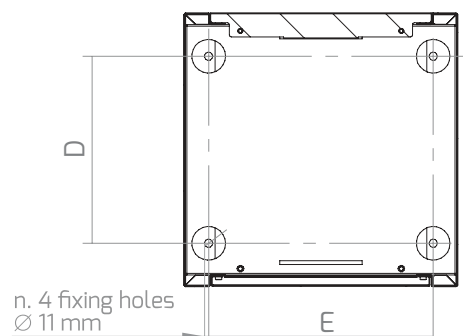
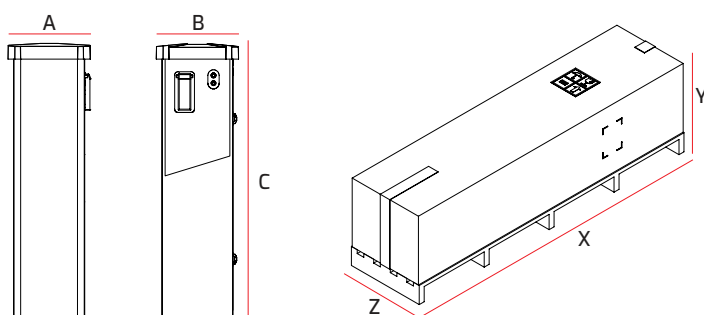



PRE WASH

MTM
HYDRO

LAVATERNI
SELF



STRIZZIA

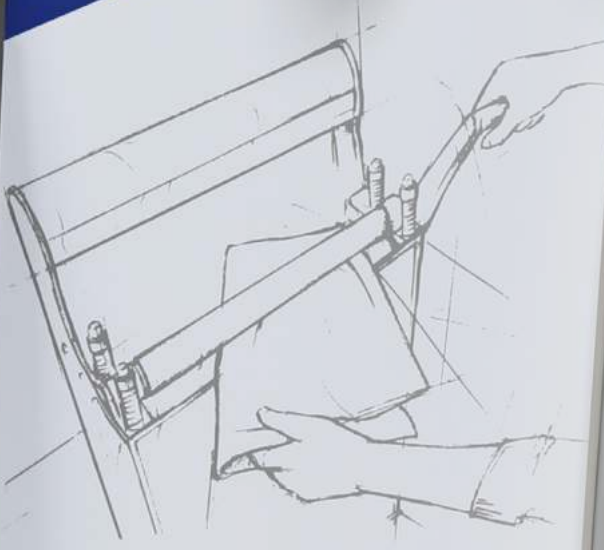

MTM
HYDRO
CAR WASH EQUIPMENT



SQUEEZY

STRIZZAPELLE / WRINGING MACHINES

SQUEEZY A MURO / WALL MOUNTING SQUEEZY



Codice Part No.	Descrizione Description	Peso Weight
3090100001	SQUEEZY A MURO	10 kg

DIMENSIONI DIMENSIONS			IMBALLO (SCATOLA CARTONE) PACKAGING (CARTON BOX)		
A (mm)	B (mm)	C (mm)	X (mm)	Y (mm)	Z (mm)
580	220	310	470	130	270

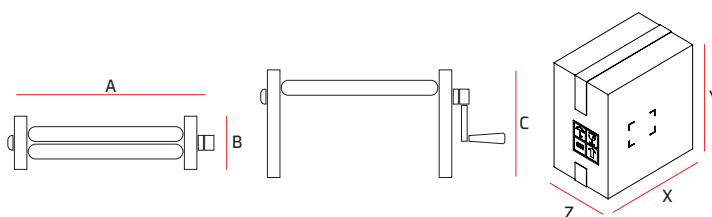

SQUEEZY A PEDALE / FOOT VALVE SQUEEZY

■ SISTEMA DI EROGAZIONE ACQUA A PEDALE

■ FOOT WATER DISPENSING SYSTEM

■ SEMPLICITÀ D'USO E MANUTENZIONE

■ EASE OF USE AND MAINTENANCE

■ REGOLAZIONE ANTIGELO: NELLA STAGIONE INVERNALE PERMETTE DI RILASCIARE UN PICCOLO FLUSSO D'ACQUA CHE EVITA LA FORMAZIONE DI GHIACCIO NELLA VALVOLA

■ ANTIFREEZE ADJUSTMENT: ALLOWS A SMALL FLOW OF WATER DURING THE WINTER SEASON TO PREVENT ICE FORMATION IN THE VALVE



CARATTERISTICHE TECNICHE / TECHNICAL FEATURES

Codice Part No.	Descrizione Description	Erogazione Acqua Water distribution	Peso Weight
3090200005	SQUEEZY	Valvola a pedale con regolazione antigelo / Foot valve with no frost adjustment	20 kg

SQUEEZY A FOTOCELLULA / PHOTOELECTRIC SENSOR SQUEEZY

■ SISTEMA DI EROGAZIONE ACQUA A FOTOCELLULA

■ PHOTOCELL CONTROLLER WATER DISPENSING SYSTEM

■ ATTIVAZIONE SENZA SFORZO

■ EFFORTLESS ACTIVATION

■ RISCALDAMENTO INTERNO PER UNA MAGGIORE PROTEZIONE INVERNALE CONTRO IL RISCHIO DI GHIACCIO

■ INTERNAL HEATING SYSTEM FOR EXTRA WINTER PROTECTION AGAINST THE RISK OF FREEZING



CARATTERISTICHE TECNICHE / TECHNICAL FEATURES

Codice Part No.	Descrizione Description	Erogazione Acqua Water distribution	Kit antigelo No frost kit	Peso Weight
3090310002	SQUEEZY	Fotocellula/Photoelectric sensor		20 kg
3090310003	SQUEEZY	Fotocellula/Photoelectric sensor	✓	20 kg

DIMENSIONI
DIMENSIONS

IMBALLO (SCATOLA CARTONE)
PACKAGING (CARTON BOX)

SCHEMA DI FISSAGGIO BASAMENTO
INSTALLATION SCHEME

A (mm)	B (mm)	C (mm)	X (mm)	Y (mm)	Z (mm)	D (mm)	E (mm)	F (mm)	G (mm)	H (mm)	I (mm)	L (mm)	M (mm)
592	580	1448	1200	350	500	460	385	490	300	120	47	170	15

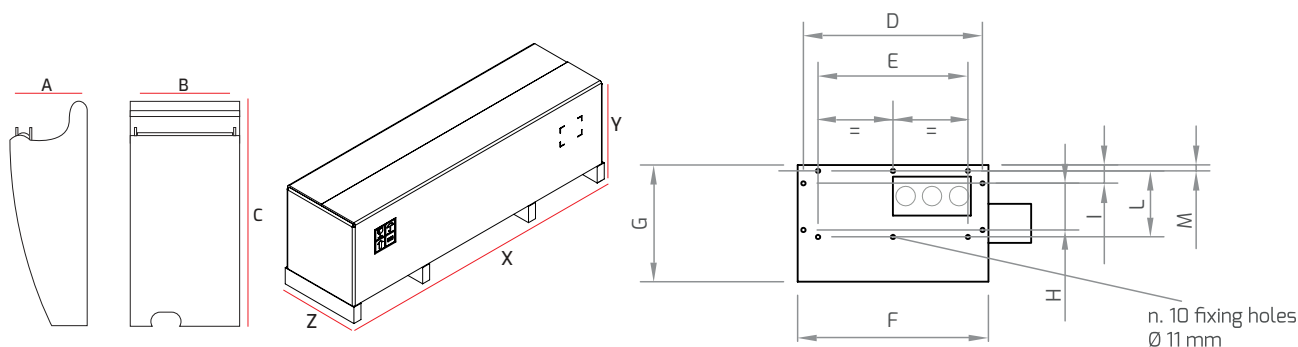

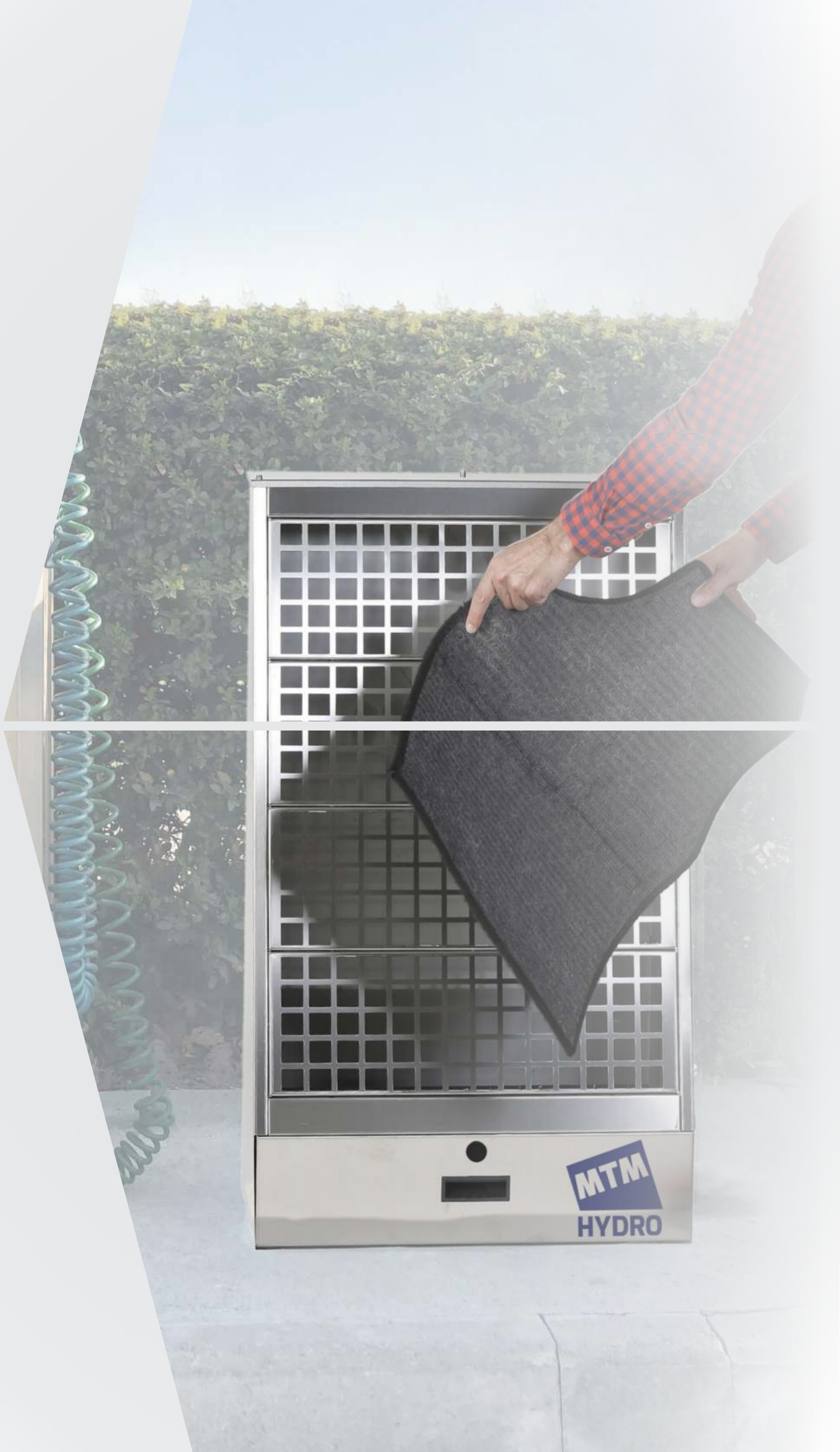



MB

BATTITAPPETO / MAT BEATER

CARATTERISTICHE / FEATURES

▼ STRUTTURA IN ACCIAIO INOX AISI 304

▼ AISI 304 STAINLESS STEEL BODY

▼ VASCA RACCOLTA RIFIUTI 30 L CON CHIUSURA ANTIVANDALO

▼ WASTE COLLECTION CONTAINER 30 L WITH VANDAL-PROOF LOCK

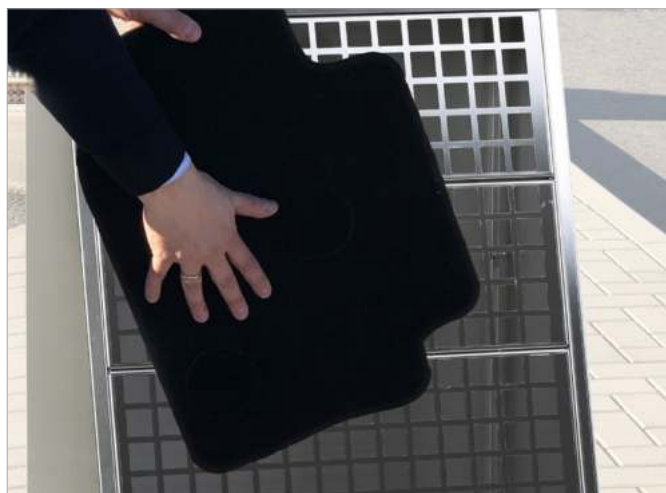

CARATTERISTICHE TECNICHE / TECHNICAL FEATURES

Codice Part No.	Descrizione Description	Peso Weight
3100100001	MBS	40 kg

DIMENSIONI DIMENSIONS			IMBALLO (SCATOLA CARTONE) PACKAGING (CARTON BOX)		
A (mm)	B (mm)	C (mm)	X (mm)	Y (mm)	Z (mm)
600	400	1000	1052	170	605

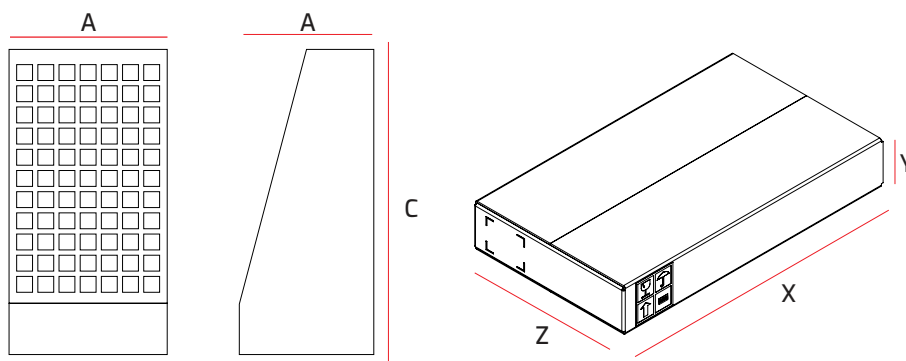

CARATTERISTICHE / FEATURES

STRUTTURA IN ACCIAIO ZINCATO

ZINC PLATED STEEL BODY



CARATTERISTICHE TECNICHE / TECHNICAL FEATURES

Codice Part No.	Descrizione Description	Peso Weight
3100200001	MB ECO	12 kg

DIMENSIONI DIMENSIONS		IMBALLO (SCATOLA CARTONE) PACKAGING (CARTON BOX)		
A (mm)	B (mm)	X (mm)	Y (mm)	Z (mm)
600	1000	1250	190	410

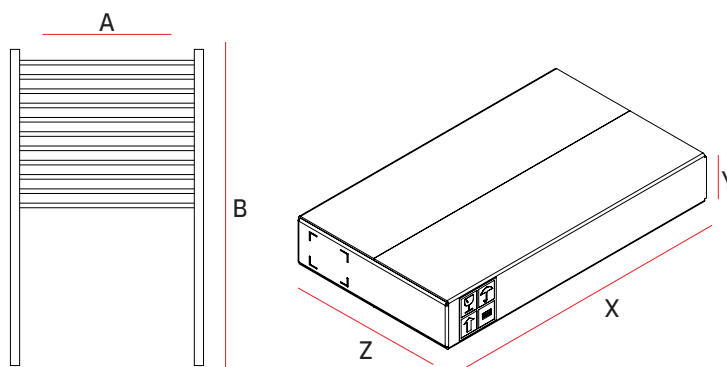



CURA & BELLEZZA
AUTO
Self-services
con touch



ARBOH
9387 73257
arboh.com

ASPIRATOR

MTM
HYDRO
CAR WASH EQUIPMENT

CARATTERISTICHE / FEATURES

- ▲ STRUTTURA IN ACCIAIO INOX AISI 304
- ▲ APERTURA CON AZIONAMENTO A PEDALE CON SISTEMA AMMORTIZZATO
- ▲ APERTURA GETTA RIFIUTI DI DIMENSIONE 17x18 cm: IMPEDISCE AGLI UTENTI DI GETTARE RIFIUTI DI GRANDI DIMENSIONI
- ▲ CASSETTO SCORREVOLE PER ESTRAZIONE SACCHETTO RIFIUTI
- ▲ SPORTELLLO ANTERIORE CON CHIUSURA ANTIVANDALO
- ▲ ADESIVE IN DOTAZIONE PER IDENTIFICAZIONE TIPOLOGIA DI RIFIUTI
- ▲ CAPACITÀ 70 LITRI
- ▲ SACCHETTO CONSIGLIATO 90 LITRI (NON IN DOTAZIONE)
- ▲ AISI 304 STAINLESS STEEL BODY
- ▲ PEDAL OPERATED OPENING WITH CUSHIONED SYSTEM
- ▲ 17x18 cm LITTER OPENING: PREVENTS USERS FROM THROWING LARGE LITTER
- ▲ SLIDING DRAWER FOR WASTE BAG EXTRACTION
- ▲ FRONT DOOR WITH VANDAL-PROOF CLOSURE
- ▲ ADHESIVE LABELS SUPPLIED FOR IDENTIFICATION OF THE TYPE OF WASTE
- ▲ CAPACITY 70 LITERS
- ▲ RECOMMENDED BAG 90 LITERS (NOT SUPPLIED)



CARATTERISTICHE TECNICHE / TECHNICAL FEATURES

Codice Part No.	Descrizione Description	Peso Weight
3110200002	PWB	27 kg

DIMENSIONI
DIMENSIONS

A (mm)	B (mm)	C (mm)	X (mm)	Y (mm)	Z (mm)
420	490	1030	1020	580	480

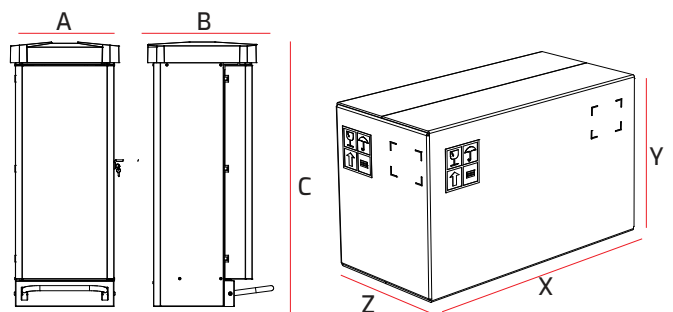
IMBALLO (SCATOLA CARTONE)
PACKAGING (CARTON BOX)



CARATTERISTICHE / FEATURES

- ▲ TEMPO CICLO PROGRAMMABILE
 - ▲ STRUTTURA IN ACCIAIO INOX
 - ▲ GETTONIERA ELETTRONICA
 - ▲ CONTA IMPULSI-CICLI
 - ▲ SPIA DI PRESENZA TENSIONE
 - ▲ PORTAMONETE IN PLASTICA
 - ▲ PREDISPOSIZIONE PER FISSAGGIO A MURO
 - ▲ ADATTO PER TENSIONE ALIMENTAZIONE MONOFASE 230V/TRIFASE 400V E ASSORBIMENTO MAX. 16A
- ▲ SETTABLE CYCLE TIME
 - ▲ STAINLESS STEEL CASING
 - ▲ ELECTRONIC COIN ACCEPTOR
 - ▲ PULSES-CYCLES COUNTER
 - ▲ WARNING LIGHT
 - ▲ PLASTIC MONEY DRAWER
 - ▲ PROVISION FOR WALL MOUNTING
 - ▲ SUITABLE FOR 230/400 V VOLTAGE AND MAX. ABSORPTION 16A



CARATTERISTICHE TECNICHE / TECHNICAL FEATURES

Codice Part No.	Descrizione Description	Tensione Voltage	Assorbimento Max. Max. Absorption	Peso Weight
3084300001	SB	400 V - 50 Hz R-S-T / 400 V - 50 Hz R-S-T+N	16 A	20 kg
3084300003	SB	230 V - 50 Hz	16 A	20 kg

ACCESSORI A RICHIESTA / ACCESSORIES ON DEMAND

Codice Part No.	Descrizione Description
0235020005	COPERTURA GETTONIERA COIN ACCEPTOR PROTECTION

DIMENSIONI
DIMENSIONSIMBALLO (SCATOLA CARTONE)
PACKAGING (CARTON BOX)

A (mm)	B (mm)	C (mm)	X (mm)	Y (mm)	Z (mm)
253	323	381	420	450	420

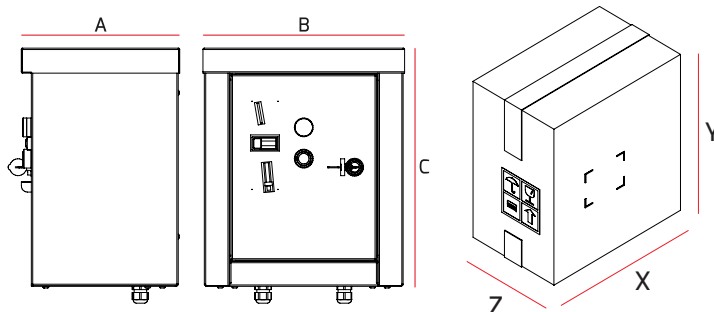



CARATTERISTICHE / CHARACTERISTICS

- ▲ STRUTTURA INTERNA ED ESTERNA IN ACCIAIO INOX
- ▲ POSSIBILITÀ DI INSTALLAZIONE ORIENTABILE A PARETE O A SOFFITTO TRAMITE LA MANIGLIA IN DOTAZIONE
- ▲ RESISTENZE ELETTRICHE CORAZZATE AISI 321 AD ALTO SCAMBIO TERMICO
- ▲ TERMOSTATO OVERHEATING DI SURRISCALDAMENTO A RIARMO MANUALE
- ▲ COMMUTATORE QUATTRO POSIZIONI (15KW, 10 KW, 0, VENTILAZIONE)
- ▲ QUADRO ELETTRICO PROTEZIONE IP55
- ▲ PREDISPOSIZIONE PER FISSAGGIO A MURO
- ▲ HIGH GRADE STAINLESS STEEL BODY
- ▲ DELIVERED WITH A FRAME ALLOWING ADJUSTABLE INSTALLATION TO A WALL OR TO A CEILING
- ▲ ELECTRONIC COIN ACCEPTOR
- ▲ SAFETY OVERHEATING MANUAL RESET THERMOSTAT
- ▲ FOUR POSITIONS SWITCH (15 KW, 10KW, 0, FAN)
- ▲ PLASTIC MONEY DRAWER INCLUDED
- ▲ IP55 ELECTRIC BOARD GRADE PROTECTION



CARATTERISTICHE TECNICHE / TECHNICAL FEATURES

Codice Part No.	Descrizione Description	Potenza Power	Tensione Voltage	Assorbimento Max. Max. Absorption	Peso Weight
3130130001	EK	15 kW	400 V - 50 Hz	32A	21 kg

DIMENSIONI
DIMENSIONSIMBALLO (SCATOLA CARTONE)
PACKAGING (CARTON BOX)

A (mm)	B (mm)	C (mm)	X (mm)	Y (mm)	Z (mm)
768	450	445	632	350	432

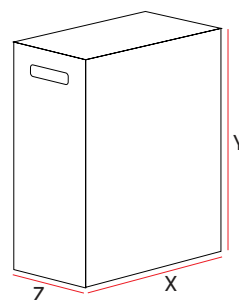
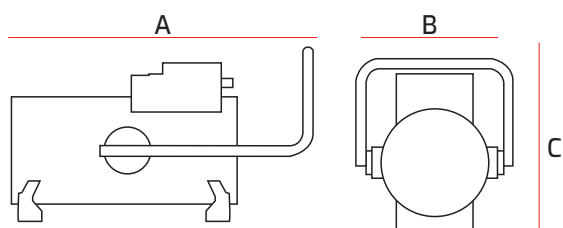

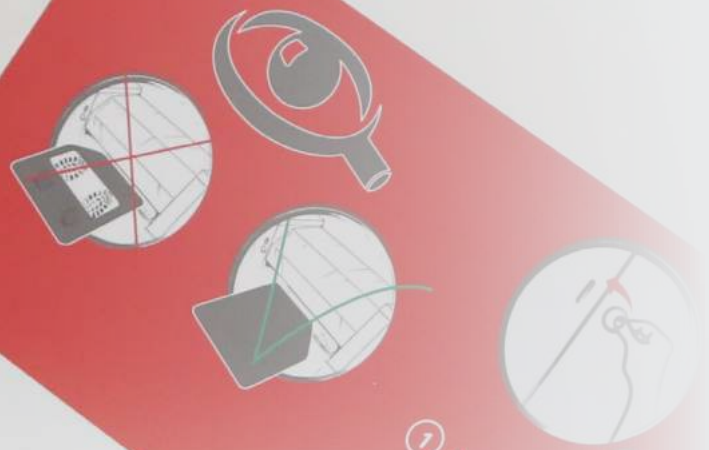

- ① WRZUĆ MONETĘ 2 zł
- ② PRANIE NA SUCHO - PRZEJDŹ DO
PRANIE NA MOKRO - WCIŚNIJ NIEBISZ

MYCIE DYWANÓW



ETICHETTE

LABELS



CARATTERISTICHE / CHARACTERISTICS

- 3 COLORAZIONI DISPONIBILI
 - DUE DIVERSE COMBINAZIONI DISPONIBILI (F.DO BIANCO O COLORATO)
 - FINITURA OPACA ANTIGRAFFIO
 - APPLICABILI SU TUTTI I MODELLI DI MACCHINA

 - 3 COLOURS AVAILABLE
 - TWO COMBINATIONS AVAILABLE (WHITE OR COLOURFUL BACKGROUND)
 - SCRATCH-RESISTANT MATTE FINISH
 - APPLICABLE ON ANY TYPE OF MACHINE

Colore Color	Descrizione Description
○	ETICHETTA HYDRO BLU / HYDRO LABEL BLUE
○	ETICHETTA HYDRO ROSSO / HYDRO LABEL RED
○	ETICHETTA HYDRO GIALLO / HYDRO LABEL YELLOW
●	ETICHETTA HYDRO BLU REVERSE / HYDRO LABEL REVERSE BLUE
●	ETICHETTA HYDRO ROSSO REVERSE / HYDRO LABEL REVERSE RED
●	ETICHETTA HYDRO GIALLO REVERSE / HYDRO LABEL REVERSE YELLOW

LE COLORAZIONI SOPRA ELENCAE VENGONO VENDUTE SENZA ULTERIORI SUPPLEMENTI SUL PREZZO DELLA MACCHINA

THE ABOVE INDICATED COLORS ARE AVAILABLE WITHOUT ANY FURTHER UPCHARGE

SOVRAPREZZO PER GRAFICHE FUORI STANDARD / SURCHARGE FOR NON-STANDARD GRAPHICS



TERMINI e CONDIZIONI GENERALI di VENDITA

Le presenti Condizioni Generali di Vendita si applicano a tutti i contratti conclusi tra MTM Hydro Srl e i Clienti.

1. L'ordine sottoscritto dal Cliente vincola il medesimo; mentre MTM Hydro Srl si riserva la facoltà di non accettarlo, dandone comunicazione scritta al Cliente entro 3 giorni dal ricevimento. Il contratto di vendita si intende concluso con l'accettazione da parte di MTM Hydro Srl attraverso l'invio della c.d. conferma d'ordine.
2. Salvo diversa pattuizione scritta, la vendita si intende effettuata Ex Works (Incoterms 2010), cioè con consegna franco fabbrica, bordo camion.
3. Il termine di consegna indicato sull'ordine ha natura indicativa. Qualora MTM Hydro Srl non sia in grado di rispettarlo ne darà comunicazione scritta al Cliente con la conferma d'ordine ed in ogni caso tale termine non potrà mai essere per nessuna ragione considerato essenziale secondo quanto previsto dalla legge italiana.
4. MTM Hydro Srl ha facoltà di effettuare consegne parziali. Le condizioni di pagamento indicate sulla conferma d'ordine valgono anche per le consegne parziali.
5. La forma ed i termini di pagamento riportati sulla conferma d'ordine emessa da MTM Hydro Srl sono vincolanti per il Cliente.
6. I pagamenti devono essere effettuati secondo le condizioni indicate nella conferma d'ordine. I prezzi indicati nella conferma d'ordine sono al netto dell'IVA di legge e di eventuali spese per tasse o imposte che sono a carico del Cliente. In caso di ritardato pagamento decorreranno gli interessi di mora in misura pari all'Euribor a tre mesi in vigore al momento delle scadenze previste maggiorato di 5 punti. In caso di ritardato pagamento il contraente dovrà altresì rifondere a MTM Hydro Srl tutte le spese ed i danni originati dall'inadempienza.
7. MTM Hydro Srl si riserva la proprietà dei prodotti venduti sino all'integrale pagamento del prezzo da parte del Cliente. Ove la riserva di proprietà dovesse decadere attraverso la rivendita, l'unione con altri oggetti, ovvero la lavorazione, essa sarà rimpiazzata da una quota di proprietà del nuovo prodotto in ragione del valore del prodotto ovvero da una quota del medesimo valore, del credito derivante dalla rivendita, che il Cliente dichiara sin da ora di cedere a MTM Hydro Srl.
8. Qualora la conferma d'ordine preveda il pagamento in più rate del prezzo, ferma la riserva di proprietà della merce che rimarrà in capo a MTM Hydro Srl, il mancato pagamento da parte del Cliente anche di una sola rata non inferiore all'ottava parte del prezzo, provocherà l'immediata risoluzione del contratto e le rate pagate resteranno acquisite da MTM Hydro Srl a titolo di indennità, salvo il risarcimento del maggior danno. Resta inoltre espressamente inteso che, salvo autorizzazione scritta della MTM Hydro Srl, la merce sino all'integrale pagamento del prezzo dovrà rimanere presso il luogo di consegna.
9. Il periodo di garanzia dei prodotti di MTM Hydro Srl, salvo diverse specifiche pattuizioni scritte, ha una durata di 12 mesi decorrenti dalla data di consegna. Al termine di tale periodo, la garanzia si intenderà automaticamente estinta, senza necessità di comunicazione alcuna o diritto di proroga. La responsabilità di MTM Hydro Srl durante il periodo di garanzia, è limitata – alternativamente ed a scelta insindacabile di MTM Hydro Srl – alla riparazione o alla sostituzione delle parti o dei prodotti che, a seguito delle opportune verifiche e ad insindacabile giudizio di MTM Hydro Srl, risultino affetti da difetti o vizi di origine.
10. La garanzia è prestata alle condizioni previste dalla legge italiana ed, in particolare, in relazione a quanto prevedono gli artt. 1490 e ss. del Codice Civile. A maggiore specificazione di quanto previsto dalla legge italiana, si precisa che la garanzia è soggetta alle seguenti ulteriori condizioni:
 - Il prodotto deve essere installato correttamente.
 - Il prodotto deve essere utilizzato conformemente alla destinazione d'uso per cui è stato progettato e costruito; l'utilizzo, in particolare per i prodotti destinati ad essere installati su macchine e/o attrezzature, è altresì condizionato al rispetto delle Direttive e delle norme cogenti.
 - Il prodotto deve essere utilizzato conformemente alle specifiche indicate sul relativo manuale o sulle relative schede tecniche di riferimento; per i prodotti destinati ad essere installati su macchine e/o attrezzature, è anche necessario seguire le specifiche di utilizzo indicate sul manuale o sulla scheda tecnica di queste ultime.
 - Il prodotto deve essere mantenuto efficiente eseguendo le operazioni di manutenzione indicate sul relativo manuale o sulle relative schede tecniche di riferimento.
 - Il prodotto non deve essere alterato, modificato o manomesso senza la preventiva autorizzazione scritta di MTM Hydro Srl; eventuali etichette e targhette sul prodotto, riportanti il marchio MTM Hydro Srl e il numero di serie e/o di matricola, non devono essere cancellate, rimosse o in alcun modo occultate.
 - Le parti di ricambio eventualmente già sostituite sul prodotto, devono essere state fornite da MTM Hydro Srl, o comunque approvate in modo scritto da MTM Hydro Srl. L'eventuale riparazione o sostituzione di componenti, del prodotto o di sue parti non estendono la durata della garanzia, che continuerà – in ogni caso – fino alla scadenza del termine di 12 mesi dalla data della consegna.
 - Il pagamento del prodotto da parte del Cliente deve rispettare le modalità stabilite all'ordine (e specificate nella conferma d'ordine inviata da MTM Hydro Srl); la garanzia non conferisce al Cliente alcun diritto di sospendere o differire il pagamento della fornitura.
11. Sono escluse dalla garanzia tutte le parti tipicamente soggette ad usura (ad esempio – a mero titolo esemplificativo – cuscinetti, spazzole, guarnizioni, materiale elettrico, ecc.) e le parti potenzialmente soggette ad ossidazione o a corrosione se non correttamente utilizzate, manutentute o custodite. Sono inoltre escluse dalla garanzia le parti e i prodotti danneggiati da cause naturali, sbalzi di tensione elettrica, atti vandalici, calamità naturali, atti di guerra, e in generale da tutte le cause evidentemente non imputabili a MTM Hydro Srl. Sono esclusi dalla garanzia i difetti o malfunzionamenti risultanti da danni accidentali, dal non corretto assemblaggio, installazione o uso del prodotto ovvero dalla mancata o insufficiente sua manutenzione. La garanzia si applica esclusivamente all'acquirente originario e non può essere trasferita a terzi. Le parti prodotte da terzi ed incluse nei prodotti di MTM Hydro Srl, sono soggette alle clausole di garanzia stabilite dai relativi produttori.
12. La restituzione a MTM Hydro Srl di parti o prodotti ritenuti difettosi, può essere effettuata durante il periodo di garanzia esclusivamente previa approvazione scritta di MTM Hydro Srl; il Cliente dovrà essere quindi espressamente autorizzato da MTM Hydro Srl ad effettuare il reso e tale autorizzazione scritta (fornita al Cliente dalla funzione Assicurazione Qualità di MTM Hydro Srl), dovrà essere allegata alla documentazione di spedizione che accompagna la merce resa. In tal senso, le parti o i prodotti ritenuti difettosi dovranno essere inviati dal Cliente a MTM Hydro Srl corredati (i) dall'autorizzazione scritta al reso, (ii) dalle presenti Condizioni Generali di Vendita con duplice sottoscrizione in calce del Cliente e (iii) dalla copia della bolla di consegna del prodotto acquistato, attestante la data di avvenuta consegna.
13. I reclami proposti dal Cliente devono essere trasmessi in forma scritta a mezzo fax al n. +39 0172 49 54 37, oppure mediante lettera raccomandata con ricevuta di ritorno, indirizzata a MTM Hydro Srl – Funzione Assicurazione Qualità – via Moglia, 33 – 12062 – Cherasco (CN) – Italy, oppure mediante email all'indirizzo info@mtmhydro.it o all'indirizzo email del commerciale di riferimento.
14. Le spese di trasporto delle parti o dei prodotti ritenuti difettosi sono a carico del Cliente; nel caso in cui in seguito all'analisi della merce resa, MTM Hydro Srl rilevi un'effettiva difettosità a lei imputabile, sarà cura di MTM Hydro Srl stessa procedere, a sua discrezione, alla riparazione o alla sostituzione di tali parti o prodotti, nel più breve tempo possibile e facendosi carico di ogni onere (analisi, documentazione prodotta, trasporto delle parti in garanzia, ecc.) e di rimborsare al Cliente i costi di trasporto sostenuti; nel caso in cui in seguito all'analisi della merce resa, MTM Hydro Srl non rilevi alcuna difettosità, oppure rilevi una difettosità a lei non imputabile, tutti i costi relativi alla gestione della pratica di reso (analisi, documentazione prodotta, trasporto delle parti, ecc.) saranno addebitati a carico del Cliente.
15. Le parti o i prodotti resi saranno riconosciuti come effettivamente "difettosi" solo se la funzione Assicurazione Qualità di MTM Hydro Srl ne abbia constatato una non conformità.
16. Nel caso in cui il Cliente richieda a MTM Hydro Srl di ricevere l'invio in sostituzione anticipata delle parti o dei prodotti ritenuti difettosi, cioè prima che MTM Hydro Srl abbia effettuato l'analisi della merce resa, nonché prima che la MTM Hydro Srl abbia definito la validità o meno della garanzia, tali parti o prodotti in sostituzione saranno inviati in vendita Ex Works (Incoterms 2010); la merce ritenuta difettosa dovrà essere restituita a MTM Hydro Srl entro 15gg decorrenti dalla data di segnalazione del cliente, a cura e a spese del Cliente stesso, a pena di decadenza della garanzia. Nel caso in cui in seguito all'analisi della merce resa, MTM Hydro Srl rilevi un'effettiva difettosità a lei imputabile, provvederà ad effettuare una nota di credito al Cliente, di importo pari a quello della vendita delle parti o dei prodotti anticipati in sostituzione.
17. MTM Hydro Srl diventerà proprietaria delle parti e dei prodotti che, una volta resi dal Cliente, siano stati da essa riparati o sostituiti in garanzia. Tenuto conto delle circostanze, MTM Hydro Srl potrà richiedere al Cliente – successivamente alla segnalazione del malfunzionamento – l'invio di documentazione idonea alla verifica in remoto della sussistenza e dell'entità di eventuali vizi o difetti ad essa imputabili; al termine di tale procedimento MTM Hydro Srl si riserva di decidere, a proprio insindacabile giudizio, se procedere all'invio in sostituzione delle parti o dei prodotti (previo reso della merce ritenuta difettosa dal cliente, al di fuori dei casi di cui all'art. 16), ovvero se programmare un intervento di riparazione presso il Cliente da parte di personale da essa incaricato o autorizzato. E' altresì previsto il caso in cui MTM Hydro Srl, considerato il valore della merce e/o la distanza tra MTM Hydro Srl e il Cliente e/o la storicità del difetto segnalato, decida che non sia necessaria la restituzione, da parte del Cliente, delle parti o dei prodotti ritenuti difettosi, e provveda quindi direttamente alla sostituzione in garanzia. In tal caso, le parti o i prodotti sostituiti rimarranno di proprietà del Cliente.
18. Il Cliente non potrà proporre alcuna azione o eccezione se non avrà prima corrisposto integralmente il prezzo della merce acquistata e degli eventuali oneri accessori.
19. Salvo dolo o colpa grave di MTM Hydro Srl, l'eventuale risarcimento del danno al Cliente non potrà comunque superare il prezzo indicato nella fattura di vendita dei prodotti contestati.
20. Tutti i rapporti tra MTM Hydro Srl e i Clienti, sono regolati secondo la legislazione Italiana; per eventuali controversie sarà esclusivamente competente il Foro di Torino.



GENERAL TERMS and CONDITIONS of SALE

These General Conditions of Sale apply to all contracts of sale stipulated between MTM Hydro and its Customers.

1. An order signed by the Customer is binding on same, but MTM Hydro Srl reserves the right to refuse an order by means of written notice to the Customer within 3 days after its receipt. The contract of sale is deemed stipulated when MTM Hydro Srl accepts it by means of its order confirmation.
2. Unless expressly indicated otherwise in the order, goods are delivered Ex Works (Incoterms 2010), loaded on truck.
3. The delivery date specified on the order is approximate. If MTM Hydro Srl is unable to deliver by such date, it will inform the Customer in writing with the order confirmation. Under no circumstances may such date be considered essential under Italian law.
4. MTM Hydro Srl has the right to make partial deliveries. The terms of payment specified on the order confirmation also apply to partial deliveries.
5. The form and terms of payment specified on the MTM Hydro Srl's order confirmation are binding on the Customer.
6. Payments must be made in conformity to the terms specified on the order confirmation. The prices specified on the confirmation of order are net of VAT under law and of any taxes or duties to be paid by the Customer. In case of late payment, overdue interest will be charged at the 3-month Euribor rate in effect at the due dates plus 5 percentage points. In case of late payment, the Customer must also reimburse MTM Hydro Srl for all costs and damages deriving from the Customer's default.
7. MTM Hydro Srl reserves right of ownership of the sold equipment until the Customer has paid the price in full. If right of ownership should lapse due to resale, combination with other products, or reworking, it will be replaced by a share of ownership in the new product based on the value of such product or by a share of equal value of the credit deriving from the sale, which the Customer hereby declares that it will transfer to MTM Hydro Srl.
8. If the order confirmation calls for payment of the price in multiple installments, without prejudice to reservation of MTM Hydro Srl's ownership of the product, the Customer's failure to pay even a single installment of not less than 1/8 (one eighth) of the price will immediately cancel the contract of sale and MTM Hydro Srl will retain any installments paid as indemnity, without prejudice to compensation for greater damages. It is understood and agreed that the product will remain at the delivery site until full payment is made, unless otherwise authorized in writing by MTM Hydro Srl.
9. The warranty period for the MTM Hydro Srl's products, unless otherwise agreed in writing, has a duration of 12 months from the date of delivery. At the end of this period, the warranty will be automatically extinguished, with no need for any notice or right to an extension. The MTM Hydro Srl's responsibility during the warranty period is limited - alternately and under unquestionable choice of MTM Hydro Srl - to the repair or the replacement of parts or products that, following the appropriate checks and under MTM Hydro Srl's discretion, appear affected by defects or origin vices.
10. The warranty is provided in accordance with the conditions laid down by Italian law and, in particular, in relation to what is foreseen by Articles 1490 et seq. of Italian Civil Code. To give more specification of what is required by Italian law, please note that the warranty is subject to the following additional conditions:
 - The product must be properly installed.
 - The product must be used according to the intended use for which it was designed and manufactured; in particular, the use of products intended to be installed on machines and/or equipments, is also subject to the compliance with the related Directives and binding force standards.
 - The product must be used in accordance with the specification prescribed on the manual or on the relevant technical data sheets; for the products intended to be used on machines and/or equipments, it is necessary to follow the specifications of use prescribed on the manual or on the relevant technical data sheet of these machines and/or equipments too.
 - The product must be efficiently maintained, performing maintenance operations prescribed on the manual or on the relevant technical data sheets.
 - The product must not be altered, modified or tampered without the prior MTM Hydro Srl's written authorization; any labels and nameplates on the product, with the MTM Hydro Srl's logo and/or with the part/serial number, must not be deleted, removed or hidden in any way.
 - The replacement parts which are already been replaced on the product, must have been provided by MTM Hydro Srl, or otherwise approved in writing by MTM Hydro Srl. Any repair or replacement of components, product or its parts do not extend the warranty period, which will continue - in any case - until the expiry of 12 months from date of delivery.
 - The payment of the product by the customer must comply with the conditions laid down order (and specified in the order confirmation sent by MTM Hydro Srl); the warranty does not give the customer any right to suspend or delay the payment of the supply.
11. Are excluded from warranty all parts typically subject to wear (for example - but not limited to - bearings, brushes, seals, electrical materials, etc.) and all parts potentially subject to oxidation or corrosion if not properly used, maintained or stored.

Are also excluded from the warranty all parts and products damaged by natural causes, electrical power surges, acts of vandalism, natural calamities, acts of war, and in general from all causes evidently not due to MTM Hydro Srl.

Furthermore are also excluded from the warranty all defects or malfunctions resulting from accidental damages, from improper assembly, installation or use of the products or from the lack or poor maintenance.

The warranty applies to the original purchaser only and cannot be transferred to third.

The parts manufactured by third parties which are included in the MTM Hydro Srl's products, are subject to the warranty clauses established by the respective manufacturers.
12. The return to MTM Hydro Srl of the parts or products which are considered defective, can be carried out during the warranty period only with the prior MTM Hydro Srl's written approval; the customer must be expressly authorized by MTM Hydro Srl to make the return and the written permission (which is provided to the Customer by the MTM Hydro Srl's Quality Assurance function), must be attached to the shipping documents which accompanies the returned goods. In this sense, the parts or the products which are considered defective must be sent by the Customer to MTM Hydro Srl together with (i) the written authorization for the return, (ii) this General Conditions of Sale with dual Customer's signature and (iii) the copy of the delivery document of the purchased product which states the original delivery date.
13. The Customer's complaints must be sent in writing by fax to the number +39 0172 49 54 37, or by a registered letter with return receipt addressed to MTM Hydro Srl - Quality Assurance dep. - via Moglia, 33-12062 - Cherasco (CN) - Italy, or by email at the email address info@mtmhydro.it or at the email address to the representative sales person.
14. The transport costs of the parts or products which are considered defective, are in charge to the Customer; if after the analysis of the returned goods, MTM Hydro Srl detect real defects imputable to her, it is up to MTM Hydro Srl proceeding, at its option, to the repair or to the replacement of such parts or products, in the shortest possible time and taking care of all charges (analysis, documentation produced, transport costs for the goods under warranty etc) and refunding the Customer for the transport costs incurred; if after the analysis of the returned goods, MTM Hydro Srl does not detect any defects or detect a defect not imputable to her, all costs related to the management of the process of return (analysis, documentation produced, transport costs etc.) will be charged to the Customer.
15. The returned parts or products will be recognized as indeed "defective" only when the MTM Hydro Srl's Quality Assurance dept. has ascertained a non-conformity.
16. In case the Customer requires to MTM Hydro Srl to receive in advance the replacement of parts or products which are considered defective, before MTM Hydro Srl has performed the analysis of the returned goods, as well as before MTM Hydro Srl has defined the validity or not of the warranty, these replacement parts or products will be sent for sale Ex Works (Incoterms 2010); the goods considered defective must be returned to MTM Hydro Srl within 15 days from the date of notification made by the Customer, by and at Customer's expense, under penalty of forfeiture of the warranty. In case after the analysis of the returned goods, MTM Hydro Srl detect real defects imputable to her, will carry out a credit note to the Customer, for an amount equal to the sale of the parts or products replaced in advance.
17. MTM Hydro Srl will become the owner of parts and products that, once returned by the customer, they have been replaced under warranty.

Considering the circumstances, MTM Hydro Srl may ask the Customer - after the reporting of the malfunction - sending appropriate documentation to verify remotely the existence and the amount of defects imputable to her; at the end of that procedure MTM Hydro Srl reserves the right to decide, in its sole discretion, whether to send a replacement parts or products (once made the return of the goods considered defective, outside of cases of art. 16), or if schedule a repair at the Customer's location by persons in charge or authorized by MTM Hydro Srl.

It is foreseen also the case where MTM Hydro Srl, considered the value of the goods and/or the distance between MTM Hydro Srl and the Customer and/or the historicity of the claimed defect, decides that it is not necessary the return of the parts or products considered defective, and she then directly provide the replacement under warranty. In that case, the parts or the products replaced will remain property of the Customer.
18. The Customer may not bring any action or make any objection unless it has already paid in full the price of the product purchased and any ancillary costs.
19. Except in case of fraud or gross negligence by MTM Hydro Srl, any damages paid to the Customer may not exceed the price of the disputed product as specified on the invoice.
20. All relations between the parties are subject to Italian law. Any disputes will be subject to the exclusive jurisdiction of the Court of Turin, Italy.

La produzione dei Componenti e Accessori MTM Hydro si svolge tutta all'interno degli stabilimenti del Gruppo. Non solo quindi l'assemblaggio finale e i controlli di qualità ad altissimi standard, ma anche tutto il processo produttivo che sta a monte, come la realizzazione degli stampi e lo stampaggio della plastica, la torneria, la lavorazione delle lamiere con laser e punzonatrice computerizzati, la saldatura robotizzata, la verniciatura in forno, nonché la realizzazione delle schede elettroniche. MTM Hydro è quindi l'unica azienda del settore che può offrire tutto questo alla propria clientela.

Grazie all'impegno e alla cura per i dettagli e agli alti standard di qualità dimostrati, l'ente internazionale DNV GL ha, da anni, riconosciuto MTM Hydro conforme ai requisiti della Gestione Qualità ISO 9001-2015. In funzione del tipo di prodotto, MTM Hydro dispone dei requisiti di omologazione e certificazione che soddisfano le caratteristiche richieste dalle normative CE e EAC.

Un'ulteriore garanzia a vantaggio della soddisfazione dei propri clienti.



The production of Components and Accessories MTM Hydro takes place entirely within the factories of the Group. In effect, not only the final assembly, made under a strict and rigid quality control, but also the whole production process that lies behind: mould making and plastic injection moulding, lathing, metal sheet work with computerized laser and punching machine, robotic welding, powder painting, and the production of electronic boards. MTM Hydro is therefore the only company in the industry that can offer all this to its customers. Thanks to the high level of commitment and the care for details and high standards of quality demonstrated, the international organization DNV GL has, from years, recognized that MTM Hydro complies with the standards of the Quality Management System ISO 9001-2015. Depending on the product, MTM Hydro can meet the requirements of the CE and EAC certifications.

That is an additional assurance for the benefit of customers satisfaction.

Follow us on



MTM Hydro srl

Via Moglia, 33 - 12062 Cherasco (CN) - Italy - T. +39 0172 427311 - F. +39 0172 495437
info@mtmhydro.it - www.mtmhydro.it